

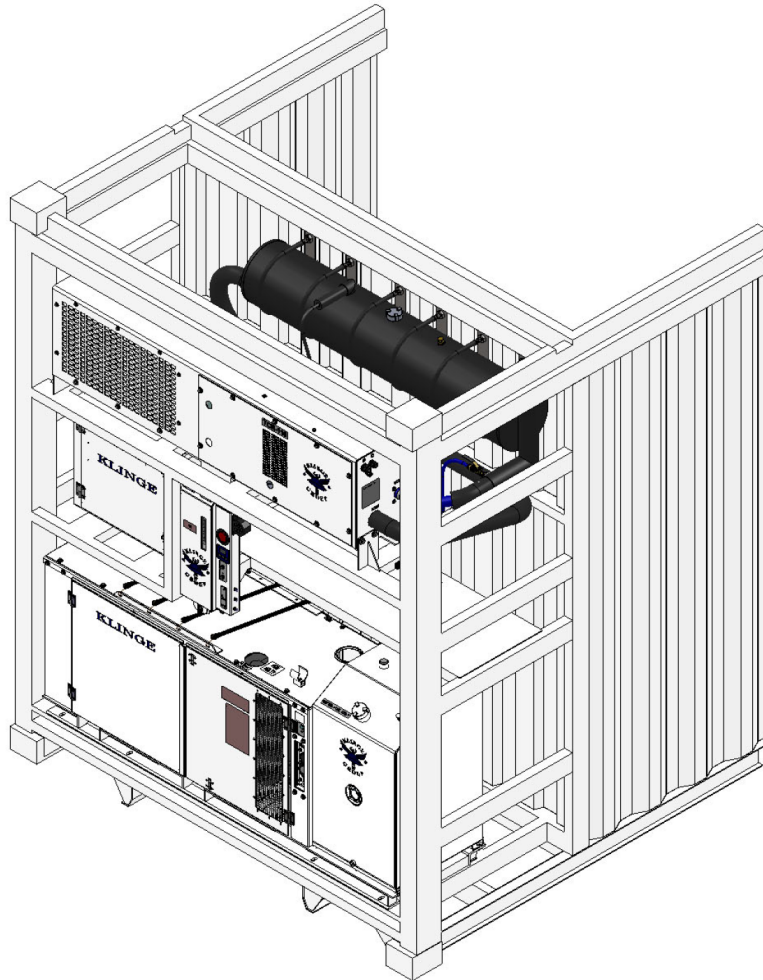

# KLINGE

## TCR-110

### OPERATION, SERVICE AND PARTS MANUAL ROAD TANKER AND ISO TANK CONTAINER REFRIGERATION UNIT



Address: 4075 East Market Street York, PA 17402-5100 USA

Telephone: 717-840-4500    Telefax: 717-840-4501

[www.klingecorp.com](http://www.klingecorp.com)

MANUFACTURED BY KLINGE CORPORATION



## **Service Request**

Requests for Service should be directed to the Klinge Service Team. The below link should be used to place all requests for service and will afford the quickest response time.

<https://klingecorp.com/request-service/>

This form will help us determine model and age of the equipment, location, basic details about the issue, who to contact and how to best handle the issues with the equipment. A service ticket number will be provided in a response email once the form is received and processed. If the equipment is out of warranty, charges may apply for extensive technical support. Additionally our Service Department can be reached via email at [technical@klingecorp.com](mailto:technical@klingecorp.com).

## **Spare Parts Request**

Requests for Spare Parts should be directed to our Parts Department via email at [spares@klingecorp.com](mailto:spares@klingecorp.com). Please have available at the time of the request the Serial Number of the equipment to ensure that the proper part is provided.

## **Use of this Manual**

The use of this manual is intended for the safe operation of the equipment described. It is therefore reasoned that persons who have the occasion to use this manual have a knowledge of mechanical and electrical systems and components addressed by its' contents. However, efforts have been made to enable persons less familiar with these systems to use this manual.

The equipment may be installed in a number of configurations. Each may have optional items and differing external details provided by third parties. The specific electrical circuit and pipe diagram are posted on the unit as decals.

Most external and internal pipework parts are standard commercially available pipe fittings and not covered here. For external pipe fitting, replace like for like, taking care to replace stainless steel with stainless steel.

Suggestions as to improvement in content and format are welcome and should be addressed to [engineering@klingecorp.com](mailto:engineering@klingecorp.com). Corrections and improvements will be included on dated revisions – the latest of which will be available upon request.

# Contents

<b>SECTION ONE – GENERAL DESCRIPTION, INSTALLATION, OPERATION.....</b>	<b>6</b>
<b>1.0 General .....</b>	<b>6</b>
<b>1.1 Refrigeration System Assembly .....</b>	<b>6</b>
<b>1.2 Scroll Compressor Assembly.....</b>	<b>6</b>
<b>1.3 Circulating Pump Assembly.....</b>	<b>6</b>
<b>1.4 Chiller Assembly.....</b>	<b>6</b>
<b>1.5 TCR-110 Weight.....</b>	<b>6</b>
<b>1.6 Glycol Storage Tank.....</b>	<b>7</b>
<b>1.7 Installation Checkout Procedure .....</b>	<b>8</b>
<b>1.8 TCR-110 Standard Operating Procedures .....</b>	<b>8</b>
<b>SECTION TWO - DETAILED FUNCTIONAL DESCRIPTION.....</b>	<b>13</b>
<b>2.1 Refrigeration System Operation .....</b>	<b>13</b>
<b>2.2 (Heat Transfer Fluid) Circulating System Operation.....</b>	<b>14</b>
<b>2.3 Pressure Controls and Safety Devices .....</b>	<b>14</b>
<b>SECTION THREE - GENERAL MAINTENANCE REQUIREMENTS.....</b>	<b>16</b>
<b>3.1 Pre-Trip Maintenance.....</b>	<b>16</b>
<b>3.2 Safety Precautions .....</b>	<b>16</b>
<b>3.3 Checking and Adding Refrigerant Charge .....</b>	<b>17</b>
<b>3.4 Checking and Adding Refrigerant Oil .....</b>	<b>18</b>
<b>3.5 Leak Detection .....</b>	<b>18</b>
<b>3.6 Evacuating the Refrigeration System .....</b>	<b>18</b>
<b>3.7 Opening the System or Unbrazing Components .....</b>	<b>19</b>
<b>3.8 Heat Transfer Fluid Circulating System.....</b>	<b>19</b>
<b>3.9 Hi-Pot Testing.....</b>	<b>20</b>
<b>3.10 General Description Klinge Corporation Thermostat.....</b>	<b>21</b>
<b>SECTION FOUR - TROUBLESHOOTING.....</b>	<b>23</b>
<b>4.1 General Information .....</b>	<b>23</b>
<b>4.2 Electronic Thermostat .....</b>	<b>23</b>
<b>4.3 Refrigeration System.....</b>	<b>23</b>
<b>4.4 Circulating System .....</b>	<b>23</b>
<b>4.5 Electrical System .....</b>	<b>23</b>
<b>4.6 PTI Form.....</b>	<b>24</b>
<b>SECTION FIVE - INSPECTION AND REPAIR.....</b>	<b>32</b>
<b>5.1 Compressor .....</b>	<b>32</b>
<b>5.2 Condenser Blower Motor and Heat Transfer Fluid Pump Motor.....</b>	<b>34</b>

**5.3 Filter Drier Replacement..... 34**  
**5.4 High Pressure Switch ..... 34**  
**5.5 Thermal Expansion Valve ..... 35**  
**5.6 Electrical Schematic..... 37**  
**5.7 Thermostat Operation ..... 38**  
**5.8 Temperature – Pressure Chart ..... 40**  
***SECTION SIX – TCR-110 SERVICE PARTS..... 42***

# **SECTION ONE – GENERAL DESCRIPTION, INSTALLATION, OPERATION**

## **1.0 General**

The TCR-110 is specifically designed to mount to a container horizontal frame rail. This TCR-110 unit is mounted to a rail at the front of the container engine area. The TCR-110 Control Box is mounted just below the unit, mounted to container integrated support rails. Power is supplied to the TCR-110 Control Box by a Klinge produced and supplied NMG-118 Generator Set, mounted at the base of the engine area of the container.

## **1.1 Refrigeration System Assembly**

Basic equipment associated with the TCR-110 includes: a scroll compressor using R-134A, a condensing section, a chiller section, a circulating pump section. An adjustable electronic thermostat controls the temperature of the cargo and the thermostat is also linked in the electrical system to control operation of the TCR-110.

## **1.2 Scroll Compressor Assembly**

The latest in refrigeration technology is applied to the TCR-110 by using components that require a low level of maintenance intervals, such as, the scroll compressor with its simplicity in design and operation. The scroll design can typically achieve higher compression ratios, which allows the compressor to produce lower temperatures for the cargo without adding additional weight.

## **1.3 Circulating Pump Assembly**

The circulating pump assembly is a close-coupled centrifugal pump and motor. The circulating pump assembly is low maintenance with sealed bearings supporting the motor and the fluid being pumped through it provides lubrication for the pump.

## **1.4 Chiller Assembly**

The chiller assembly is a 3-ton rated unit. It is a brazed flat plate constructed unit designed to be maintenance free. The chiller is the interface between the TCR-110 refrigerant and the tank glycol or heat transfer medium.

## **1.5 TCR-110 Weight**

The dry weight is approximately 144 kg, 316 lbs.

The majority of the weight is towards the face of the unit and is supported by the mounting rail.

### **1.5.1 Installation of TCR-110 onto Frame Member**

The unit has two holes fitted with M10 X 1.5 nut inserts, on each end. These are to be used in conjunction with a simple angle to attach the unit to the mounting rail.

Because the container frame rail is steel and the unit body is constructed of aluminum, we ask for an electrolytic barrier such as a 1-mm thick gasket of synthetic rubber or plastic to be placed between beam and unit.

### 1.5.2 Connecting TCR-110 to the Glycol Storage Tank

The unit is shipped complete with the first piece of the inlet and outlet pipework. This includes a simple sight glass made from a length of translucent wire reinforced plastic pipe. These pipes must be connected to the glycol storage tank. The normal arrangement would be to have a suitable length of pipe welded directly to the pipes provided and either hard or flexible pipework to the glycol storage tank.

## 1.6 Glycol Storage Tank

This unit requires a separate, externally mounted, atmospheric pressure, storage/expansion tank for the cooling medium.

The glycol storage tank has approximately 77 liter capacity and is mounted high on the front wall of the container, behind the TCR-110 unit.

The pipe from the atmospheric pressure glycol storage tank to the unit may be clear plastic but must be of large bore, approximately 40mm.

The pipe may be wire reinforced plastic or similar as long as it can withstand the extremes of the operating temperature.

### 1.6.1 Cleanliness of the Heat Transfer Fluid System

New cooling systems are typically coated with oil, grease, or protective film during fabrication. Welding byproducts, flux and scale that would not normally cause a problem with a steam system can cause a problem with the Heat Transfer Fluid heat exchanger – the chiller.

Dirt will migrate to the chiller (a plate type heat exchanger) and may block the small gaps between each plate. Because of this, thoroughly cleaning the new system is important.

A solution of 1 to 2% trisodium phosphate (TSP) (available at most hardware stores) can be used with water for flushing the cooling pipes.

The system volume can be calculated at this stage by metering in the cleaning material.

This cleaning should be completed prior to connecting the TCR-110 unit.

We suggest that a gauze or muslin cloth be used to filter and observe the output of the cleaning medium. Use the lack of returning dirt as a guide to cleanliness.

NOTE: As it is an inherently closed loop system, the unit purposely does not have the restriction of an in-line filter in the heat transfer fluid line and depends on the heating system being cleaned at the initial charge filling.

### 1.6.2 Venting

To initially charge the system entrapped air needs to be released.

The pump is not self-priming, however, with sufficient head of liquid from the initial filling, the pump may be run intermittently to assist in venting air from the system.

## **1.7 Installation Checkout Procedure**

In order to ensure that the TCR-110 will operate as designed and provide trouble free operation, it is important that this checkout procedure be completed.

### **1.7.1 Circulating system Charging Procedure**

The circulating system is charged with heat transfer fluids. Refer to paragraph 3.3 for details of system charging.

### **1.7.2 Operational Testing**

Operational testing should be accomplished on the initial installation per clause 1.8. See clause 3.1 regarding pre-trip maintenance.

## **1.8 TCR-110 Standard Operating Procedures**

### **1.8.1 Pre-Starting Check**

It is important to perform a basic check prior to any operation of the TCR-110. It will assist the operator with assessment of system reliability. The items that should be checked are:

1. Visually inspect unit for physical damage. Observe for signs of leaks. Check condenser coils and clean if required.
2. Check hold-down bolts and ensure that they are not loose.
3. Open the electrical control box and inspect it to ensure that all connections are tight and electrical components are secured properly. Check that the door gaskets seal properly.

### **1.8.2 Starting the TCR-110**

Connect the main power plug into a receptacle rated at 480V AC to supply power to the unit. Check to ensure that CB1, CB2, and CB3 are in the "ON" position.

**NOTE:** The TCR-110 is equipped with an electronic thermostat when the unit is started a function test (paragraph 1.8.6) should be done to ensure the thermostat will function properly.

Start the unit by placing the "ON/OFF" switch in the "ON" position. Adjust the thermostat temperature to the desired set point and allow the unit to run for a few minutes. Observe oil level in the compressor and refrigerant level in the sight glass of the receiver and the filter assembly.

- The compressor is not fitted with a pre-heater. On initial startup, particularly after a long period of storage, the compressor may make a loud vibration noise. This is normal for a few seconds, however, if it persists, stop the unit and check to ensure that the three-phase wiring is correct and that the compressor cycle of rotation is correct.
- The compressor sight glass may have a surge of bubbles on initial startup. These bubbles should start to clear within the first few minutes of operation. The colder the ambient temperature is the longer this may take.

- The receiver sight glass (lower) should be flooded, with the bead inside floating. The upper sight glass should be free of liquid with the bead resting. However, on initial startup the gas and liquid may migrate around in the system until a stable condition is reached. This could take up to 30 minutes but should become stable shortly after the bubbles clear from the compressor sight glass.

### 1.8.3 Temperature Selection

Once a temperature is set, the control point is determined, and the thermostat governs the cycles of the TCR-110. The temperature indicated is dependent on the installation of the probes.

The thermostat logic is based on two control probes, one in the cargo and one in the cooling \ heating medium to heat or cool the cargo. The “cargo” probe is placed in the glycol storage tank. By definition, the heat transfer medium must be higher or lower than the cargo. The temperature of some cargo may be varied by raising or lowering the temperature of the heat transfer fluid. Locally sub-cooling or locally overheating the cargo at the point at which the heat transfer fluid first comes in contact with the tank may be a problem with some liquids. This is particularly true when the carriage temperature is near the freezing point of the cargo. The heat transfer fluid limit temperature prevents this. See section 1.8.5.

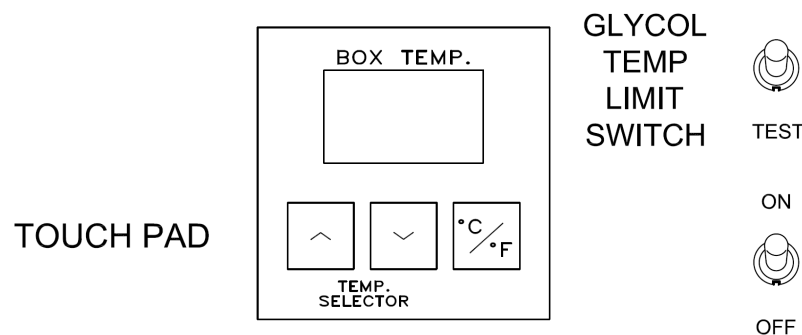

#### Creating a temperature set point:

1. Pressing the **UP** (^) or **DOWN** (v) key causes the display to show the current set point.
2. After the current set point is displayed, each pressing of one of these keys will increment or decrement the display by one whole degree.
3. Holding a key pressed will cause the display to change one degree each half second.
4. Simultaneously pressing both keys causes the current set point to be saved. This set point will be used until another set point is chosen, even if power is removed from the thermostat.
5. The display automatically returns to normal mode approximately 5 seconds after the last key pressed.

The equipment can be protected from accidental or unauthorized changing of the set point by using a PIN Code. If a PIN Code is in use, the below step by step process for entering the PIN Code allows you to change the Set Point.

1. When the unit is in operation the current Set Point will be displayed by pressing either the UP or DOWN button. This will display the current Set Point.

2. When you press either the UP or DOWN button again the word “Pin” will be displayed.
3. When the word “Pin” is displayed you then press the C/F Key one time.
4. The display will now show 0 as the first digit, at this time you will need to enter the first digit of the PIN Code.
5. Once the first digit has been entered press the C/F key to move to the second digit.
6. The display will now show 0 as the second digit, at this time you will need to enter the second digit of the PIN Code.
7. Once the second digit has been entered press the C/F key to move to the third digit.
8. The display will now show 0 as the third digit, at this time you will need to enter the third digit of the PIN Code.
9. Once the third digit has been entered press the C/F key to confirm the PIN CODE that you have entered.
10. If the PIN Code that has been entered is not correct the Temperature Display will read “Pin”.
11. If the code that has been entered is correct the Temperature Display will show the Return Air Temperature. At this point the Set Point can be set through the normal process. It should be noted that the Set Point will remain unlocked for 3 minutes after the PIN Code has been entered. After 3 minutes the PIN Code will need to be entered again.

**NOTE:** If PIN code protection is used for the equipment and the PIN code needs to be changed for security reasons, an authorized user of the equipment must contact the Klinge Service Department by email at [technical@klingecorp.com](mailto:technical@klingecorp.com) for instruction.

#### Changing temperature mode:

1. The thermostat can operate in either degrees **C**entigrade (**C**) or degrees **F**ahrenheit (**F**).
2. Pressing the **C/F** key causes the display to indicate the current mode. This is indicated by a **C** or **F** in the right character of the display. The right most decimal point in the display is also illuminated when in **F** mode.
3. Each pressing of the **C/F** key causes the mode to change.
4. After selecting degrees C or degrees F, pressing either the up or down key will cause the currently selected mode to be saved and the display will immediately return to normal mode.
5. The display automatically returns to normal mode approximately 5 seconds after the last key pressed.

#### 1.8.4 Temperature Sensor Probe

The temperature sensing probe is a thermistor placed in a sealed (epoxy filled) metal tube, which is connected to a two conductor shielded cable. The temperature signal from the probe is relayed to the thermostat through this cable. An open or shorted probe will be indicated.

Accuracy of the probes is:

TEMPERATURE RANGE	TOLERANCE
-40°C to -20°C	+/-0.75°C
-20°C to -10°C	+/-0.4°C
-10°C to 70°C	+/-0.2°C

Checking of temperature should be done with an instrument with equal or better accuracy. The thermostat cannot be calibrated.

If the controlling probe has an open or shorted circuit, the thermostat will call for cooling at all times. When failure occurs the cooling light will start flashing.

If a probe or cable becomes defective, check the probe assembly and the thermostat connection first to confirm a shorted or open circuit. Then disconnect the probe to determine whether the probe or cable is defective.

**WARNING:**

**It is important that the sensor is properly mounted. Use an ohmmeter to check probes. A short circuit indicates 0 Ohms resistance. An open circuit indicates infinite Ohms resistance. Good readings should agree with the chart below:**

PROBE RESISTANCE CHART		
Probe at Ambient Temperature		K-Ohms (Approx.)
°C	°F	
+ 25	+77	10.0
+ 20	+68	12.4
+ 15	+59	15.7
+ 10	+50	19.9
+ 5	+41	25.3
0	+32	32.6
- 5	+23	42.6
- 10	+14	55.3
- 15	+5	72.9
- 20	- 4	97.0
- 25	-13	130.3

1.8.5 Setting the Upper and Lower Limit for Heat Transfer Fluid

The function of this setting is to limit “local under cooling” or “local over heating” of the cargo. In order for the circulating heat transfer fluid to cool the cargo it must be at a lower temperature than the cargo. This is not normally a problem, but for some cargoes the ideal temperature is as near to its critical point as is practical. If this is the case, you may set the heat transfer fluid temperature limit at 5°, this will allow the controller to deliver heat transfer fluid 5° lower than the set point. For heated cargoes a heat transfer fluid temperature limit of 5° will allow the controller to deliver heat transfer fluid at 5° above the set point. The setting is an “off set” limit on either side of the set point temperature, not an absolute temperature. In a case when it is not required or when the cargo will not be affected by sub-cooling or overheating, set the limit high. It is suggested, in this case, to leave the limit set at 15° or more. To set the limit, hold the glycol temp / set limit switch down while adjusting the touch pad as described above (creating a temperature set point page 10)

### 1.8.6 Function Test of the Electronic Thermostat Assembly

**Make sure helium compressor is not turned ON. Since it will cause automatic amperage checks to be incorrect.**

To initiate the function test of the electronic thermostat, simply hold the test switch down “CLOSED POSITION” and turn the unit "ON". All the LED indicators will flash, and the unit will proceed into the function test. When the test is completed the TCR-110 will continue to operate normally. A complete explanation of the function test can be found in paragraph 3.10.6.

After completion of the function test (approximately 1 min., 4 seconds) check the amperage of the compressor motor, condenser blower motor and heat transfer fluid pump. The maximum amp rating is on the electrical schematic.

Adjust the temperature set point to 0° C (32° F). Check the refrigerant level in the receiver sight glass after approximately 15 minutes of continuous running with the system full operation, cooling mode. Reset the required temperature and limit bandwidth.

## **SECTION TWO - DETAILED FUNCTIONAL DESCRIPTION**

### **2.1 Refrigeration System Operation**

The TCR-110 refrigeration system is uncomplicated, easy to operate, and requires very little maintenance. Central in the TCR-110 is the scroll compressor, which represents the next generation in refrigeration technology and has several advantages over more conventional compressor styles. For example: the scroll form is designed to provide higher compression ratios than normally found in typical compressors. There is a dynamic discharge valve that provides improved energy efficiency when operating at higher compression ratios; a liquid injection system has been added to provide cooling to the compressor at low temperature operations; and also, a Teflon impregnated bronze bearing in the compressor motor improves reliability. This type of compressor is suitable with the demanding applications that will be required of the TCR- 110.

The scroll is designed around two intermeshed and offset scrolls. One of these scrolls is orbital and the other one is fixed. The center of the orbiting scroll travels a circular path around the fixed scroll. This movement creates crescent shaped pockets between the two scroll elements. Low-pressure suction gas is trapped as each pocket is formed. Continued motion of the orbital scroll moves the gas pocket towards the center where maximum compression is reached, and the discharge port is located.

The scroll compressor is hard-mounted to the TCR-110 frame. This is to prevent excessive external vibration in our ‘transport’ application, reducing maintenance of the system piping end connections. Vibration is further minimized by the design of the piping in the TCR-110, which allows transient vibration created by the compressor during start-up to dissipate without causing harm to the system.

The TCR-110 is capable of operation in all temperature ranges and with the added option of a heater assembly the cargo can be managed effectively and efficiently. An electronic thermostat controls the temperature of the product. See section 3.10 for details of thermostat.

System components also include a coil condenser assembly with fan and motor to force airflow across the coils. A plate type heat exchanger which is the interface between the refrigeration system and the circulating system; a thermal expansion valve (TXV); compressor inlet and outlet manual hand valves; filter-dryer and sight glass assembly are also included. There is a heat exchanger that allows any remaining refrigerant in a liquid state due to low temperature operations to convert to a gas prior to entering the compressor.

The safety systems included in the refrigeration system help to protect it from excessive pressures and temperatures and prevent operation of the compressor in a high vacuum condition. The system is equipped with high pressure control and the scroll compressor is fitted with an Internal Pressure Relief (IPR) valve. The compressor motor is fitted with conventional internal line break thermal protection. A discharge line thermostat is installed in the compressor control circuit. This thermostat has a cutout setting that does not allow the compressor temperature to reach unsafe levels. All of these controls will cause the motor protector to trip and shut down the compressor.

#### **2.1.1 Liquid Injection System**

The low temperature operation of the TCR-110, down to -40 °C (-40 °F), requires that a liquid injection system be used to aid in controlling the compressor temperature. The advantage of this system is that it tends to be self-regulating. As pressure increases in the scroll, the demand for liquid injection increases. Since more cooling is needed at high compression ratio conditions, this automatic increase in liquid is exactly what is needed. With liquid injection on the scroll compressor there is a loss of capacity or mass flow at the inner pocket injection point.

## **2.2 (Heat Transfer Fluid) Circulating System Operation**

The circulating system is designed to be compatible with heat transfer fluids. The heat transfer fluid used in the system is decided mostly by its application. The circulating system consists of a close-coupled centrifugal pump and motor assembly, a relief valve, an expansion tank system, a plate-type heat exchanger and associated piping enabling connection to the glycol storage tank.

The pumped fluid lubricates the close-coupled pump assembly as it passes through the assembly. Maintenance is reduced on this unit by using sealed bearings and eliminating the alignment between pump and motor. The motor is rated at 0.5 horsepower and capable of handling fluids with temperatures of -40°C (-40°F).

The glycol storage tank system provides a place for the expansion of either the heat transfer fluid during temperature changes, or on a limited basis, acts as a storage area for some additional coolant.

The plate-type heat exchanger is the interface between the refrigeration system and the glycol storage tank. It is a 3-ton chiller made of a corrosion resistant metal and is maintenance free. Associated piping is included in the construction of the cooling system that will enable the operator to connect from the glycol storage tank to the TCR-110 using standard flexible hose connections. This connecting system can be adapted at the factory or in the field to fit many applications.

## **2.3 Pressure Controls and Safety Devices**

The TCR-110 has incorporated many safety devices and protective controls that aid in preventing damage to the unit and the cargo being handled, adding also a measure of personal safety. The safety devices control the pressures and temperatures while the unit is operating.

High pressure is controlled by a pressure switch set to open at 31 bar (450psig) and close at 21 bar (300psig). This switch will signal the controller which de-energizes the compressor contactor to shut down the system preventing high-pressure damage.

As an aid to preventing too low of a condensing temperature, capacity is controlled in the scroll compressor. This is accomplished by using a discharge temperature control (DTC) valve that injects a controlled amount of refrigerant back into the compressor. A liquid injection system has been added to provide cooling to the compressor. An injection port is internally connected to an inner pocket of the scroll mechanism for liquid refrigerant injection. This pocket is separated from the suction inlet, so no loss of capacity or mass flow results from injecting at this point. The DTC valve monitors the flow of liquid refrigerant into the injection port, based on the temperature of the thermal element located in the top cap thermal well of the compressor.

The scroll compressor is also equipped with an internal pressure relief (IPR) valve, which opens when the differential pressure from suction to outlet reaches an unacceptable limit. Opening this valve causes the motor protection to open and stop the compressor. This IPR valve prevents compressor over pressurization.

Installed in the compressor discharge line is a discharge line thermostat. This thermostat is designed to prevent the compressor from operating above its maximum discharge temperature. This thermostat will cut out the compressor and stop the motor, preventing burnout of the motor and damage to the scroll; it opens at 104°C (220°F) and closes at 77°C (170°F).

## SECTION THREE - GENERAL MAINTENANCE REQUIREMENTS

### 3.1 Pre-Trip Maintenance

Pre-trip maintenance is necessary for the operator to feel confident that the TCR-110 refrigeration system will perform adequate cargo handling. Pre-trip maintenance is simple to perform, and if conscientiously applied, will enhance the reliability of the unit. Routine pre-trip maintenance will also add to the service life of the unit. See Section 4.6 for information regarding downloading of PTI forms. It is suggested that the operator uses this form as the basis of an in-house quality control form customized for local circumstances reporting procedures etc. and translating them to the language of the mechanic, using the form.

### 3.2 Safety Precautions

**WARNING:** R-134a is heavier than air. It will collect at low levels and displace oxygen in confined areas. If you experience dizziness, shortness of breath, and have a sweet taste in your mouth, feel tired, or have nausea, remove yourself from the area immediately and seek medical attention. DO NOT continue working until the area is properly ventilated and you are cleared by medical personnel.

All service and maintenance procedures should be performed in accordance with local, city, and state, federal and national laws or ordinances or rules. Avoid discharge of refrigerant directly into the atmosphere.

When any work is to be performed on the components of the refrigeration system, always make sure that the equipment is electrically disconnected to avoid accidentally starting equipment when maintenance personnel are working. It is recommended that a lockout / tagout program be in place when performing maintenance on the unit.

A thorough study of the electrical diagram is recommended before any work should begin on the electrical system. Understanding the voltages present and the location of components within the electrical system can avoid the potential for a life-threatening injury.

Do not exert excessive pressure when tightening a flare nut assembly within the refrigeration pipe work. The flare could split, and the refrigerant charge could be lost. Always use the "Two Wrench System" when applying pressure to a flare nut fitting when tightening.

Always wear the proper Personal Protective Equipment (PPE) when working on the system. Ensure that others around you wear PPE also. Goggles, face shields, and gloves should be available and used by the technician to avoid injury. Other PPE as required for the task should be readily available and used.

Never attempt to heat refrigerant under any circumstances. Avoid any application where heat is necessary to inject refrigerant into a system. Refrigerant is a highly pressurized gas or liquid and rapid expansion due to heating could be explosive and result in death.

Always secure or close the refrigerant cylinder valve after use. Install all caps and covers and do not allow the cylinder to be dropped or hit by objects. To prevent explosive damage to the cylinder neck and valve, be certain that the cylinder protective cap is on when moving.

Do not allow the refrigerant to come in contact with a flame-heated surface, flare, cigarette or any sort of heated object. When refrigerant is heated above 649° C (1200° F) it can produce a deadly gas, Phosgene, which is odorless and colorless and can cause death.

Be aware of your surroundings and work safely. Do not work from a height without proper equipment and safety measures in place. Do not allow people to stand below you or work above you. Tie off tools that may fall from a height and allow for a 1m (3ft) drop. This should allow for plenty of freedom of movement.

A manifold gauge set should always be used to determine if the refrigerant charge has been removed. The manifold gauge set should also be used when charging the refrigerant system, checking a cylinder charge, performing routine maintenance or any other task that would require monitoring of pressures within the refrigeration system. Ensure that the manifold gauge set does not become contaminated with foreign substances. If suspected, clean the gauge set thoroughly before the next use.

### 3.2.1 Non-Condensable Gases

Air and non-condensable gases in any system gather in the receiver above the liquid. This will result in above normal discharge pressures. These gases can be removed during operation by purging through a valve provided for this purpose at the receiver. To purge, use recycle equipment and connect to purge valve. Open purge valve a small amount. Note any significant difference in the discharge pressure. Repeat this procedure until the discharge pressure is normal.

## 3.3 Checking and Adding Refrigerant Charge

The refrigerant charge should only be checked when the unit is operating at full load. Make sure the compressor is running loaded by observing that the refrigeration system temperature is at least 12°C below the outlet of the circulating system at the outlet of the chiller. If the temperatures cannot be verified set the thermostat at -9°C (16°F) and check to be sure compressor is loaded before checking charge.

The TCR-110 is charged with refrigerant at the factory. The nominal factory charge can be found on the unit data plate. A nominal charge for an ambient temperature of 32°C (90°F) is applied before shipment. At low ambient below 32°C (90°F) there may be some flashing or bubbles appearing in the sight glass. It should not be assumed that the unit is low on refrigerant. At low ambient temperatures, some of the refrigerant may "hide" in the coil assemblies. If this condition is present, it may be necessary to block the airflow access the coil assembly to raise discharge pressure. For a circulating system temperature of 2°C (35°F) the discharge pressure should be 26 Bar ± .7 Bar (375 ± 10 psig), at -18°C (0°F) the discharge pressure should be 21 Bar ± .7 Bar (310 ± 10 psig).

When the discharge pressures are as described, allow the unit to continue to operate for about 15 minutes allowing the system to stabilize. Check the sight glasses on the receiver. The ball(s) in the bottom sight glass should be floating continuously. The ball(s) in the upper sight glass should not be floating. It is important to have the proper charge of refrigerant in the system. Too much or too little refrigerant will reduce the cooling capacity of the system. Always

determine the cause for low refrigerant in the system before adding more. It is recommended that a leak check be performed.

When adding refrigerant be sure to maintain discharge pressures as described in this section. Rapid charging of only the suction side of the scroll compressor can lead to a condition called "scroll lock" This is a no-start condition for the compressor. To avoid this condition, it is preferable to apply system charges from both the high- and low-pressure sides of the compressor at a rate that will prevent this condition from occurring.

To add small quantities of refrigerant to the system, it is preferable to add gas on the low-pressure side or suction side of the compressor. Accomplish this with the compressor operating. There will be little or no interference in the operation of the system. When determined that sufficient refrigerant has been charged into the system, check suction and discharge pressures for proper levels. Observe sight glass and receiver levels. If all is satisfactory, return unit to normal operating conditions.

### **3.4 Checking and Adding Refrigerant Oil**

The TCR-110 is charged with 2.4kg of R-134a refrigerant.

Only polyol ether can be provided to the scroll compressor. The only recommended lubricants are Klinge part number K11-00416-00, Copeland Ultra 22 CC, Mobil EAL Arctic 22 CC, or ICI EMKARATE RL 32CF. Use of any lubricant not recommended will render the warranty void.

**Note:** The TCR-110 has been factory set with the correct charge of oil. Normal use should not require additional oil.

The oil level in the scroll compressor should be maintained at the midpoint of the sight glass. Immediately after start-up of the compressor the oil level in the reservoir will fluctuate. It is advisable to monitor the oil level a few minutes after start-up to ensure that there is enough oil in the compressor. If the oil level is low, below the center of the sight glass, it will be necessary to add oil to the compressor. Normal oil level should be maintained at the mid-level of the sight glass.

### **3.5 Leak Detection**

There are two methods of leak detection that will be discussed in this manual. The first is testing with soap suds solution. This method will reveal large leaks and is sometimes a good method. However, because it will only detect large leaks it is not recommended for use when determining system tightness.

The second method of detecting leaks is by using an electronic leak detector. There are several models available and all perform the same basic function. They are capable of detecting very small leaks and are also capable of determining system tightness. This type of leak detector is recommended when troubleshooting the system for refrigerant leaks.

### **3.6 Evacuating the Refrigeration System**

Do not use the scroll compressor as a vacuum pump to evacuate the system. It is not designed to operate in a high vacuum and excessive wear of the scroll will occur. Use a vacuum pump designed for the purpose, one that is capable of drawing 0.15 mm Hg or better to the part of the system that has been opened. Continue this until all moisture and air has been removed.

Whenever it is necessary to open the system for any reason, always take care to prevent the entrance of moisture or air into sections of the system. Air almost always contains moisture and can lead to reduced reliability and shorten the life of the unit.

### **3.7 Opening the System or Unbrazing Components**

If the refrigerant is removed from only the high side of the unit, it is possible for the scroll compressor to seal and prevent removal of refrigerant from the low-pressure side. It is important to remember to check both the high- and low-pressure sides for pressure before opening or unbrazing system components.

Whenever it is necessary to open a charged or functioning system to make repairs or replace component parts, it is necessary to comply with local, regional, federal, or government regulations or laws regarding the handling of refrigerant. It is recommended that recovery and recycle equipment be used when handling refrigerants.

Steps should be taken to prevent contamination of a brazed joint. Check the type of compound used to seal the joint. It is recommended that silver solder and flux be used where required for joining and sealing joints in the refrigeration system. Do not use soft solder to join or seal joints or leaks. Use of soft solder on the TCR-110 piping systems will void the warranty.

### **3.8 Heat Transfer Fluid Circulating System**

The circulating system component of the TCR-110 is straightforward and simple to maintain. General maintenance consists of purging and venting and filling when operations require that it be done. Be sure that when handling heat transfer fluids there is adequate personal protective equipment and spill prevention in place. The circulating system is an open-air system that is to say that the system does act open to the atmosphere. A glycol storage tank allows for the contraction and expansion of the fluid in the circulating system.

Air in the circulating system would promote corrosion, increase maintenance and decrease reliability. To aid in preventing air from being entrapped to the system there is an optional air purger installed that allows any trapped air to escape.

#### **3.8.1 Filling Circulating System**

First read section 1.6.1 on cleaning the system.

There are two types of heat transfer fluid systems.

The open system- With the vents open or even temporarily removed, additional liquid may be added directly to the glycol storage tank. Once the liquid can be seen in the plastic sight-glass the pump may be operated intermittently. Additional liquid may be added to the glycol storage tank. With a column of liquid in the vertical pipe from the glycol storage tank the pump will be

self-priming but may quickly displace the volume in the vertical pipe. Stopping the pump, adding liquid to the glycol storage tank, re-running the pump for a few seconds, stopping it and adding more liquid may have to be repeated a number of times until liquid fills the system. The system will be considered full when the expansion tank is approximately  $\frac{3}{4}$  full. When using the metal expansion tank, the liquid level can be viewed by removing the fill cap and looking inside. A measuring stick could be used to indicate  $\frac{3}{4}$  full. Once this condition is achieved, the unit should be both self-priming and purge itself of entrapped air.

### Schrader valve type

These small automotive tire type valves require any cover and cap to be removed and the center pin of the valve to be depressed as in a pneumatic tire. Always replace the stainless-steel cap and any outer cover.

## **3.9 Hi-Pot Testing**

Hi-Pot testing is done to determine if there is a significant increase in current leakage in motor windings. High current leakage can, in most cases, indicate a breakdown in motor insulation resistance.

Hi-Pot testing of the motor will aid in determining current leakage. The motor is normally dry and free of contaminants that could increase the leakage rate. If a high current leakage is measured, it is possible that a failure of the motor is occurring.

### 3.9.1 Compressor Motor

Scroll compressors are configured with the motor in the bottom of the shell. It is likely that the scroll compressor will be immersed in refrigerant when liquid is present in the shell. Hi-Pot testing with liquid refrigerant in the shell can show higher leakage due to the conductivity of liquid refrigerant vapor and/or oil. To lower the current leakage reading, operate the system for a brief period of time – about ten minutes – and test again. There should be a reduction in the amount of current leakage.

### 3.9.2 Condenser Blower Motor

This totally enclosed motor is equipped with shielded ball bearings, which require no lubrication. The motor is designed to operate satisfactorily with line voltages, which are within 10% of nameplate values. The motor is protected by an automatic reset klixon, which is normally closed. In case of overheating, the klixon will open and the motor will stop.

#### **CAUTION:**

**Replacement blower motors may be manufactured for opposite rotation from what is required. Always check for proper rotation and, if required, reverse two of the three leads.**

### 3.9.3 Circulating Pump Motor

Hi-Pot Testing of the circulating pump motor will aid in detecting problems in the motor windings that could lead to failure of the circulating system. This motor is normally dry and free of contaminants that could increase leakage. If a high current leakage condition is measured, it could indicate a failure of the motor.

### 3.10 General Description Klinge Corporation Thermostat

This microprocessor device contains all components and software necessary to select those functions required to maintain an accurate temperature. The selection is based on signals received from the probes and the display panel. It is designed to operate in ambient temperatures of  $-40^{\circ}\text{C}$  ( $-40^{\circ}\text{F}$ ) to  $70^{\circ}\text{C}$  ( $158^{\circ}\text{F}$ ). It will control temperature settings (set point) of  $-29^{\circ}\text{C}$  ( $-20^{\circ}\text{F}$ ) to  $29^{\circ}\text{C}$  ( $84^{\circ}\text{F}$ ).

#### 3.10.1 LED Indicators

The narrow edge of the thermostat contains (8) LEDs. These LEDs, in conjunction with the thermostat's labels serve a dual purpose.

1. The front thermostat label, with illuminated LED(s) indicates the operating status of the unit.
2. The side label is used for the function test. The lit LED indicates the function being tested.

#### 3.10.2 Inputs

Input signals to the device consist of:

1. The heat transfer fluid or cargo temperature probe.
2. Set point (desired cargo setting).
3. Limit setting (offset from set point).
4. Signal to function test from SW2.

#### 3.10.3 Relays

Output signals from the device are by a means of (8) relays.

- (4) Relays are single pole single throw, normally open.
- (4) Relays are single pole double throw.

Outputs used in the system are:

1. Compressor ON (cooling)
2. Condenser blower ON.
3. Phase sensor ON. (Pump)

Each output relay has a red LED mounted on the circuit board adjacent to the relay to indicate the relay is energized.

These LEDs are only visible from the side of the device and are for diagnostic purposes only.

#### 3.10.4 Temperature Falling

1. Compressor cycles off at set point.
2. If equipped, Heat cycles ON at  $0.5^{\circ}\text{C}$  ( $0.9^{\circ}\text{F}$ ) below set point.

These are inhibited if the heat transfer fluid temperature is outside the heat transfer fluid limit setting.

### 3.10.5 Temperature Rising

1. Compressor cycles ON at 0.5°C (0.9°F) above set point.
2. There is a one-minute OFF delay of the compressor before it can cycle ON again, regardless of the temperature rise.
3. If equipped, Heat cycles OFF at set point.

### 3.10.6 Function Test (Labels on the right side of the thermostat)

To initiate the function test, hold the test switch (SW2) closed and switch unit ON/OFF switch to ON. The microprocessor will flash all LED indicators and then proceed through the function test. There are (7) steps in the function test. However, only (5) are used on this unit. The LED will light to indicate the function being tested and will flash if there is a problem.

The function test steps are as follows:

1. Energize pump and phase contactor
2. Energize condenser blower
3. Energize compressor
4. Energize heat (optional)
5. Check cargo probe
6. Check heat transfer fluid probe
7. Energize unload (optional)

### 3.10.7 Other Functions

1. If the temperature pull-down rate is less than 0.05°C (0.1°F) per hour, the alarm LED will light, and the temperature failure LED will flash. This function is locked out within +/- 2°C (3.6°F) of the set point.
2. After reaching the set point, if the temperature varies more than +/- 2° C(3.6°F) for more than 120 minutes, the alarm LED will light, and the temperature failure LED will light.
3. The alarm LED indicators are reset by turning the control system power OFF or by the temperature reaching the set point.

## **SECTION FOUR - TROUBLESHOOTING**

### **4.1 General Information**

This section is intended to aid the technician in determining the cause of a malfunction of the TCR-110. This section is as complete as possible, however, in troubleshooting it is not always possible to target every cause. The experience of the technician and this chapter should enable correction of a malfunction to the TCR-110.

### **4.2 Electronic Thermostat**

The thermostat is mostly solid state and therefore has a high degree of reliability.

If the controller is suspect first check:

1. That the probe is in close contact with the point being measured.
2. That the system has heat transfer fluid in it and has been vented.
3. That no external wires are loose or have been shorted out.
4. Undertake a function test.

The controller cannot be repaired or reprogrammed in the field, but a core replacement price is offered for a unit returned that can be repaired. Contact Klinge Corporation for a replacement.

### **4.3 Refrigeration System**

The refrigeration system is relatively simple. Elements have been incorporated into the design that reduce maintenance and increase reliability. The result is also a system that is straightforward to troubleshoot. Most problems encountered in the refrigeration system can be found and corrected with minimum difficulty. Refer to Refrigeration Fault Logic Table for fault logic decisions for troubleshooting a malfunction.

### **4.4 Circulating System**

The circulating system is another straightforward system, simple in design and operation. As the system is designed as a closed system there is no requirement for an inline filter. If, however, on initial charging of the system, or in service, the system is contaminated with solid matter it will collect at the chiller and restrict the flow and therefore the capacity of the system. If this happens the chiller may be reverse flushed with high pressure, high volume liquid such as wet steam.

The pump, being a moving part, has a service life estimated at 4 to 5 years of regular service in one-way trade. There is a replacement kit available, which includes bearings and seals for in-service replacement.

Quote the serial number of the unit when ordering the in-service replacement kit.

Refer to the Circulating System Fault Logic Table for fault logic decisions for troubleshooting a malfunction.

### **4.5 Electrical System**

The electrical control system for the TCR-110 is rugged and compact. The technician is expected to have some knowledge of electrical applications related to refrigeration systems. An understanding of electrical drawings and schematics is also helpful. Refer to table below for the fault logic decisions for troubleshooting a malfunction.

## **ELECTRONIC THERMOSTAT FAULT LOGIC**

### **DURING FUNCTION TEST**

Use the label on the side of the thermostat

All LEDs flash

Step 1 Phase Test LED 3 illuminated

Step 2 Glycol Pump LED 4 illuminated

Step 3 Condenser Blower LED 5 illuminated

Step 4 Compressor LED 6 illuminated

Step 5 Heat (Optional) LED 7 illuminated

Step 6 "NOT USED" LED 8 illuminated

Step 7 Alarm Horn LED 9 illuminated

Step 8 Probes LED 10 illuminated

### **DURING OPERATION**

Use the label on the front edge of the thermostat

#### **4.6 PTI Form**

It is important that a Pre-Trip Inspection (PTI) be completed prior to each shipment.

The TCR-110 PTI form can be found on Klinge's website at: <http://www.klingecorp.com/pti/>.

## REFRIGERATION SYSTEM FAULT LOGIC

Malfunction	Probable cause	Recommended corrective action
No power to the unit	Power plug not connected	Connect the power plug
	Source not operating	Verify that power source is operating
	Loose cable connections	Check cable connections
Unit will not start	Tripped CB1, CB2 or CB3	Reset circuit breakers
	No secondary control voltage present at T1	Check primary side of 460V AC. If no voltage present refer to “NO POWER TO UNIT”
		Check all electrical connections for tightness. Recheck primary voltage Replace defective T1
The compressor operates noisily	Flooded suction on start	Considered normal, check for reverse rotation of compressor if present
	Faulty liquid injection valve	Replace
	Faulty current sensing relay	Replace
	Faulty capacity control pressure switch	Replace
Bubbles forming in sight glass	Low refrigerant charge	Check refrigerant level and charge
Oil level is low	Oil refrigeration leak	Leak check and evacuate the system
	Oil consumed during normal use	Recharge oil to proper level in the compressor

<b>Malfunction</b>	<b>Probable Cause</b>	<b>Recommended corrective action</b>
Moisture indicator is “wet”	Non-condensable gas in the system	Remove non-condensable gases and check refrigerant charge
	Excessive moisture in the system	Evacuate, and leak check the system
Refrigerant charge is low	Leak in the system	Leak check and evacuate the system

### CIRCULATING SYSTEM FAULT LOGIC

<b>Malfunction</b>	<b>Probable cause</b>	<b>Recommended corrective Action</b>
Unit not cooling	Air trapped in the circulating system	Vent circulating system Add additional cooling medium Check to see if glycol storage tank is vented to atmosphere
Pump working but no flow	Cooling medium too viscose	Check concentration of cooling medium
The sight glass is not clear	Cooling medium contaminated	Test sample

## 4.7 Alarm Code

Alarm LED indicators are reset if control system power is turned OFF.

**Note:** If the display would display a “P” number, this indicates that you have accidentally entered the Configuration Menu. In order to prevent accidental changes please turn the unit off and back on.

ALARM CODE	ALARM NAME	ALARM CONDITION	ALARM CLEAR	SUGGESTION FOR REPAIR	ALARM LEVEL (HIGH = SYSTEM CHANGEOVER)
A01	Glycol sensor short	The sensor or the wire to the sensor is shorted.	If there has not been an alarm for 60 minutes, then the alarm is cleared by the controller. Or by C/F key.	Replace sensor. Check wire for damage.	High
A02	Glycol sensor open	The sensor or the wire to the sensor is open.	If there has not been an alarm for 60 minutes, then the alarm is cleared by the controller. Or by C/F key.	Replace sensor. Check wire for damage.	High
A03	Cargo sensor short	The sensor or the wire to the sensor is shorted.	If there has not been an alarm for 60 minutes, then the alarm is cleared by the controller. Or by C/F key.	Replace sensor Check wire for damage.	High
A04	Cargo sensor open	The sensor or the wire to the sensor is shorted.	If there has not been an alarm for 60 minutes, then the alarm is cleared by the controller. Or by C/F key.	Replace sensor Check wire for damage.	High
A05	Heater sensor short	The sensor or the wire to the sensor is shorted.	If there has not been an alarm for 60 minutes, then the alarm is cleared by the controller. Or by C/F key.	Replace sensor Check wire for damage.	High
A06	Heater sensor open	The sensor or the wire to the sensor is open.	No action.	Replace sensor Check wire for damage.	High
A07	Compressor sensor short	The sensor or the wire to the sensor is shorted.	If there has not been an alarm for 60 minutes, then the alarm is cleared by the controller. Or by C/F key.	Replace sensor Check wire for damage.	High
A08	Compressor sensor open	The sensor or the wire to the sensor is open.	No action.	Replace sensor Check wire for damage.	High
A09	Pressure transmitter out of range.	The sensor or the wire to the sensor is defective.	If there is a pressure transmitter on the unit, then the alarm is cleared by display C/F key. Else no action.	Replace sensor Check wire for damage.	Low

A11	Phase sensor fail	The sensor cannot find the 3 phase at the main power. (Test is performed at unit start up)	If the sensor passes a new test, then the alarm is cleared by the controller. Or by C/F key.	Check Main power Check glycol pump. Check condenser Fan. Check CT sensor. Check wire for damage.	High
A12	Low current on heat element	The heat element is using too little power. (Test is performed at unit start up)	The alarm is cleared by display C/F key	Check if relay is switched on. Check output from controller.	Low
A13	High current on heat element	The heat element is using too much power. (Test is performed at unit start up)	The alarm is cleared by display C/F key	Check if relay is switched on. Check output from controller.	Low
A14	Low current on pump motor	The pump motor is using too little power. (Test is performed at unit start up)	The alarm is cleared by display C/F key	Check if relay is switched on. Check output from controller.	Low
A15	High current on pump motor	The pump motor is using too much power. (Test is performed at unit start up)	The alarm is cleared by display C/F key	Check amps at pump motor. Check if pump is rotating.	Low
A16	Low current on condenser fan	The condenser fan is using too little power. (Test is performed at unit start up)	The alarm is cleared by display C/F key	Check if relay is switched on. Check output from controller.	Low
A17	High current on condenser fan	The condenser fan is using too much power. (Test is performed at unit start up)	The alarm is cleared by display C/F key	Check amps at condenser motor. Check if fan is rotating.	Low
A18	Low current on compressor	The compressor is using too little power. (Test is performed at unit start up)	If there has not been an alarm for 60 minutes, then the alarm is cleared by the controller. Or by C/F key.	Check if relay is switched on. Check overload relay. Check output from controller. Check gas at the ref. system. Check if HP is switched out.	Low
A19	High current on compressor	The compressor is using too much power. (Test is performed at unit start up)	If there has not been an alarm for 60 minutes, then the alarm is cleared by the controller. Or by C/F key.	Check amps at compressor motor.	Low

A20	Different current on heat element	There is a difference between the phases. (Test is performed at unit start up)	The alarm is cleared by display C/F key	Check if relay is missing a phase. Check if voltage is too low. Check the motor element for defect with a clamp ammeter	Low
A21	Different current on pump motor	There is a difference between the phases. (Test is performed at unit start up)	The alarm is cleared by display C/F key	Check if relay is missing a phase. Check if voltage is too low. Check the motor element for defect with a clamp ammeter	Low
A22	Different current on condenser fan	There is a difference between the phases. (Test is performed at unit start up)	The alarm is cleared by display C/F key	Check if relay is missing a phase. Check if voltage is too low. Check the motor element for defect with a clamp ammeter	Low
A23	Different current on compressor	There is a difference between the phases. (Test is performed at unit start up)	If there has not been an alarm for 60 minutes, then the alarm is cleared by the controller. Or by C/F key.	Check if relay is missing a phase. Check if voltage is too low. Check the motor element for defect with a clamp ammeter	Low
A28	Float switch failure	The float switch has been activated	If there has not been an alarm for 60 minutes, then the alarm is cleared by the controller. Or by C/F key.	Check glycol level, it is most likely low and needs to be topped off.	High
A29	Temperature sensor difference too large under test.	Difference between the temperature sensors is too large. (Test is performed at unit function test)	The alarm is cleared by display C/F key	Check sensors for correct reading.	Low

A30	Container temperature too low	<p>If the rate of temperature change is too slow, less than 0.06 °C / hour, (i.e. Not heating fast enough) and the cargo probe temperature is outside of a 2°C window of the set point there is an alarm.</p> <p>OR if the cargo probe temperature has been inside a 2 °C window of set point at some time since power up or since the set point was changed, and if the glycol temperature is outside a 2°C window of set point for 2 hours or more, there is an alarm.</p>	<p>If the return air is inside the 2°C window of the set point, then the alarm is cleared by the controller.</p> <p>Or by C/F key.</p>	<p>Check sensors for correct reading. If unit is equipped for heat, ensure heater is functioning properly.</p>	High
A31	Container temperature too high	<p>If the rate of temperature change is too slow, less than 0.06 °C / hour, (i.e. Not cooling fast enough) and the cargo probe temperature is outside of a 2°C window of the set point there is an alarm.</p> <p>OR if the cargo probe temperature has been inside a 2 °C window of set point at some time since power up or since the set point was changed, and if the cargo temp is outside a 2°C window of set point for 2 hours or more, there is an alarm.</p>	<p>If the return air is inside the 2°C window of the set point, then the alarm is cleared by the controller.</p> <p>Or by C/F key.</p>	<p>Check refrigerant gas. Check TX valve. Check glycol pump motor. Check glycol flow. Check compressor. Check if condenser is dirty. Check condenser fan motor.</p>	High
A34	Compressor temp too high	<p>If the compressor sensor is above 120°C</p>	<p>If there has not been an alarm for 60 minutes, then the alarm is cleared by the controller.</p> <p>Or by C/F key.</p>	<p>Check refrigerant gas. Check if there is air in the refrigeration system. Check if condenser is dirty. Check condenser fan motor.</p>	High
A35	Temperature Fault	<p>These conditions will produce an open at terminal 31.</p> <p>If terminal 31 has been open in 60 minutes, then the alarm is set.</p>	<p>The alarm is clear by display C/F key</p>	<p>Check setting of temperature alarm recorder. Check glycol pump motor. Check gas on system. Check TX valve.</p>	High

A36	High pressure cut out. Cool mode	If there has been 3 HP cut out in an hour when the unit is in cool mode, then the alarm will be set to on.	The alarm is clear by display C/F key	Check condenser fan motor is running. Check if condenser needs cleaning. Check if there is air in the gas system. Check adjustment of suction regulator valve. Check HP switch for fault.	High
A41***	Set point different Sys 1/Sys 2	If the systems have set points 1°C or greater difference, the alarm is set.	The alarm is cleared when system set points are made less than 1°C different.	Check both system set points and make equal.	Low
A42***	No response from other unit	If a signal is not received between the 2 systems for a time of 3 minutes the alarm is set.	The alarm is cleared when a signal is received between both systems.	Check connection of Can Bus cable.	Low
A43	Heat element temperature too high	Heater core probe has exceeded its safety limit.	The alarm is clear by display C/F key	Ensure proper glycol level in system.	Low
A49	Set point missing.	If set point is not loaded in controller, then the display will show -45	The alarm is clear by putting set point in controller.	This is normally if new software is uploaded to the controller.	High

\*\*\* Alarm codes A41 and A42 will only be applicable when 2 TCR-110's are assembled to one container, as a redundant system.

- **Low Level** A Low-Level Alarm will give the Alarm Number on the Touch Pad. The alarm lamp will light. The horn will not sound.
- **High Level** A High-Level Alarm will give the Alarm Number on the Touch Pad. The alarm lamp will light, and the horn will sound. If the container is equipped with two TCR-110 units as a dual system, the control logic will automatically switch operation to the backup system.

## SECTION FIVE - INSPECTION AND REPAIR

### 5.1 Compressor

#### 5.1.1 Compressor Motor Protection

The compressor motor of the TCR-110 is equipped with an internal overload device. This device will stop the compressor if a problem arises which causes the motor to overheat. When the motor cools sufficiently, the overload will reset automatically.

#### 5.1.2 Compressor Lubrication

The compressor in the TCR-110 is a scroll compressor and operates only in one direction. In order to check the oil level in the compressor, a sight glass is provided in the front of the shell, allowing the oil inside the crankcase to be visible at all times.

Since the oil level will vary with operating conditions, it should only be checked after the compressor has been running long enough for the crankcase to warm up to operating conditions.

#### 5.1.3 Adding Oil

**Caution: This unit uses R-134a refrigerant. Therefore, mineral oil type lubricant cannot be used.**

**The only oil approved by the manufacturer is Polyol ester lubricant, Klinge Part Number K11-00416, Copeland Ultra 22 cc, Mobile EAL Arctic 22cc, or ICI EMKARATE RL 32 CF.**

**The use of any lubricant not recommended by the manufacturer will render the warranty void.**

#### 5.1.4 Compressor Motor Burnout

**Caution: Acids are formed during motor burnout. Use rubber gloves and eye protection when working on the system or handling contaminated parts.**

When a hermetic motor burnout occurs, the stator winding insulation decomposes forming carbon, water and acid. To prevent contamination of the refrigerant system and repeat motor failures, definite steps **MUST** be taken to ensure the refrigerant circuit is kept clean from contamination.

**Damage to a compressor caused by failure to clean the system properly after burnout constitutes abuse and is not covered by the terms of the warranty.**

### 5.1.5 System Cleaning Procedure After Hermetic Motor Burnout

A hermetic motor burnout failure can be detected by observing an obvious electrical fault or by a strong burnt odor to the refrigeration gas released at the discharge valve port. After a motor burnout, the following procedure must be followed to clean the system and thus prevent failure of a replacement compressor.

Flushing out a refrigeration system with R-11 should not be considered. Scientific evidence has linked ozone depletion to R-11 emissions. In case of a motor burnout, Copeland recommends the filter drier cleaning procedure. Basically, this involves the use of approved filter driers incorporated with an adequate desiccant (not a filter only) in both the liquid and suction lines.

If there is no suction line filter and it is difficult to install a suction line filter, it is permissible to use a liquid line filter. However, in step 9 (below), instead of removing the suction line filter drier, inspect the compressor suction strainer and clean if necessary.

The filter drier procedure has been proven to be very economical, especially when the refrigerant in the system is recovered using safe recovery techniques. This can be easily accomplished if the compressor is fitted with service valves.

1. Recover refrigerant from the system. Remove the inoperative compressor and install the replacement.
2. Since the normal color of refrigerant oil varies from oil to oil, take a sample of oil from the replacement compressor and seal in a small bottle for comparison purposes after the cleaning operation is complete. Suitable 2 oz. bottles are easily obtainable.
3. Inspect all system controls such as expansion valve and solenoid valve. Clean or replace if necessary. Remove or replace any filter driers previously installed in the system, and clean or replace any filters or strainers.
4. Install the recommended size remote filter drier in the suction line and an oversized filter drier in the liquid line.
5. Evacuate the system.
6. Charge through the remote filter drier with the refrigerant, which was removed and recovered. Add additional refrigerant if necessary.
7. Start the compressor and put the system in operation. After (4) hours, stop the unit and replace the filter driers.
8. After completion of step 7, allow the unit to operate for 48 hours. Check the odor (**smell cautiously**) and compare the color of the oil with the sample taken in step 2. If an acid test kit is available, test for acid content. If the oil is discolored and smells acidic, or if the moisture indicator indicates a high moisture content in the system, change the filter driers. The compressor oil can be changed if considered desirable. Allow the system to operate for an additional 48 hours and recheck as before. Repeat until the oil remains clean, odor free and the color approaches that of the original sample.
9. Replace the liquid line filter drier with one of the normally recommended size. Remove the suction line filter drier.
10. After the cleaning procedure is complete, recheck in approximately two weeks to ensure that the system condition and operation is completely satisfactory.

## 5.2 Condenser Blower Motor and Heat Transfer Fluid Pump Motor

**Caution: Replacement motors may be manufactured for opposite rotation from what is required. Always check for proper rotation, and if required, reverse two leads.**

### 5.2.1 Condenser Blower

The motor and power cord connections are sealed with a watertight potting compound or silicone; no adjustments can be made here. **Caution:** Do not cut the cable short.

If the motor fan must be removed from the motor shaft for any reason, be sure that the blower wheel is installed with the hub on the motor side. This wheel has forward curved blades.

Install the wheel on the assembly but do not tighten the cap screws holding the motor to the motor mount.

Extreme care must be taken to align the blower wheel and the inlet ring to be concentric and to have the wheel centered between the two inlet rings.

When all alignments are made, secure the assembly by tightening the motor mount cap screws. Attach the power wires and check for rotation. After the replacement has been made and the assembly put in place, pull the access cable into the compressor area. Coil and secure the excess cable.

### 5.2.2 Pump Assembly

These procedures are the same to replace the pump motor seal or the pump seal. The heat transfer fluid connections will need to be removed for servicing the motor or the pump. The pump suction has a 1- $\frac{1}{4}$  inch National Pipe Tapered (NPT) connection; this is removed through the hole in the right side of the unit. The pump discharge has a 1 inch. NPT connection and is accessible through the compressor area. There is a pipe coupling with a neoprene gland held together with two bolts and nuts inside the insulation. This insulation will need to be replaced after service.

The motor and power cord connections are sealed with a watertight potting compound or silicone; no adjustments can be made here. **Caution:** Do not cut the cable short.

Attach the power cable and check for rotation. The rotation should be clockwise, to the right facing the motor fan.

## 5.3 Filter Drier Replacement

This system is a closed system with all the joints brazed. The drier is not replaceable without evacuating the system.

To replace the drier:

Attach a manifold gauge set to the suction valve service Schrader port. The refrigerant recovery line is to be fastened to the manifold gauge. This line will be used to evacuate the system and perhaps add refrigerant.

## 5.4 High Pressure Switch

The high-pressure switch functions automatically to open or close the contactor coil circuit upon increase or decrease in discharge pressure.

To replace a pressure switch:

1. A Schrader valve is installed to prevent loss of refrigerant when removing the switch.
2. The cable should not be cut. The wire is to be sealed outside of the junction box.

## 5.5 Thermal Expansion Valve

The thermal expansion valve automatically maintains superheat of the refrigerant gas leaving the chiller. The only maintenance that the valve may require is to check that the bulb is making good contact with the suction line. The thermal bulb is secured at a pre-selected point on the suction line positioned at 4 or 8 o'clock, by a perforated metal strap. If, for any reason, this bulb is removed from the suction line, care must be taken to ensure that the bulb is correctly replaced and insulated. Ensure the bulb is properly insulated to prevent surrounding air from contacting the bulb.

**Note:** If the body must be changed for any reason, it is not necessary to disassemble the new TX valve, but use extreme care to prevent warping of the new valve body due to excess heat being applied during brazing. To prevent warping, it is necessary to use wet rags to reduce heat buildup of the valve body. Direct the torch tip away from the body.

### 5.5.1 Replacement of Defective Thermostat Element

The only part of the thermal expansion valve that might fail is the power element. The power element can be easily changed.

1. Before removing the power element, the refrigerant must be removed from the system. To do this follow the steps under drier replacement.
2. Remove the power element bulb from the suction line and unscrew the power element. When removing the element check to be sure the push rods are in place and have not fallen out.
3. Install the new element hand tight. After hand tight, turn element clockwise 60° (movement equal to one hex flat).

### 5.5.2 Expansion Valve Adjustment

The expansion valve is set and tested at the factory before shipping. When the application or operating conditions require a different setting, the valve may be adjusted to obtain the required operating superheat. The expansion valve adjustment is capped for protection. Remove the protective cap. To reduce the superheat, turn the adjustment stem counter-clockwise or to the left. To increase, turn the adjustment stem clockwise or to the right.

Make adjustments one-half turn at a time. Allow the system to run and achieve steady state before determining if further adjustment is required. It may take approximately 15 minutes after each adjustment before a new balance can be acquired.

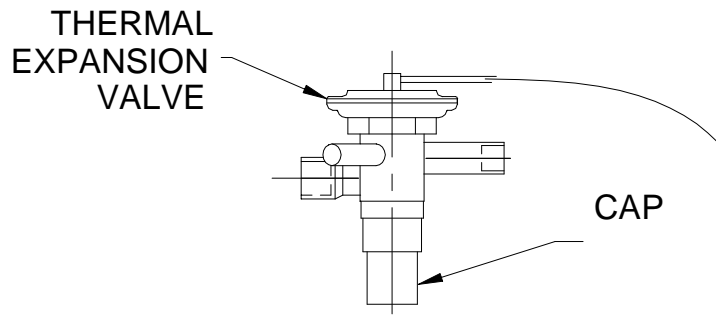

**Note : Refer to the temperature/pressure chart at the end of this section, when calculating the superheat:**

1. Measure the temperature of suction line at the point the bulb is clamped.
2. Obtain the suction pressure that exists in the suction line at the bulb by either of the following methods:
  - a. If the valve is externally equalized, a gauge in the external equalizer line will indicate the desired pressure directly and accurately.
  - b. Read the gauge at the suction valve of the compressor. To the pressure add the estimated pressure drop through the suction line between bulb location and compressor suction valve. The sum of the gauge reading and the estimated pressure drop will equal the approximate pressure at the bulb.
3. Convert the pressure obtained in 2a and 2b to saturated temperature by using the Temperature/Pressure chart provided at the end of this manual.
4. Subtract the two temperatures obtained in 1 and 3, the difference is the superheat.

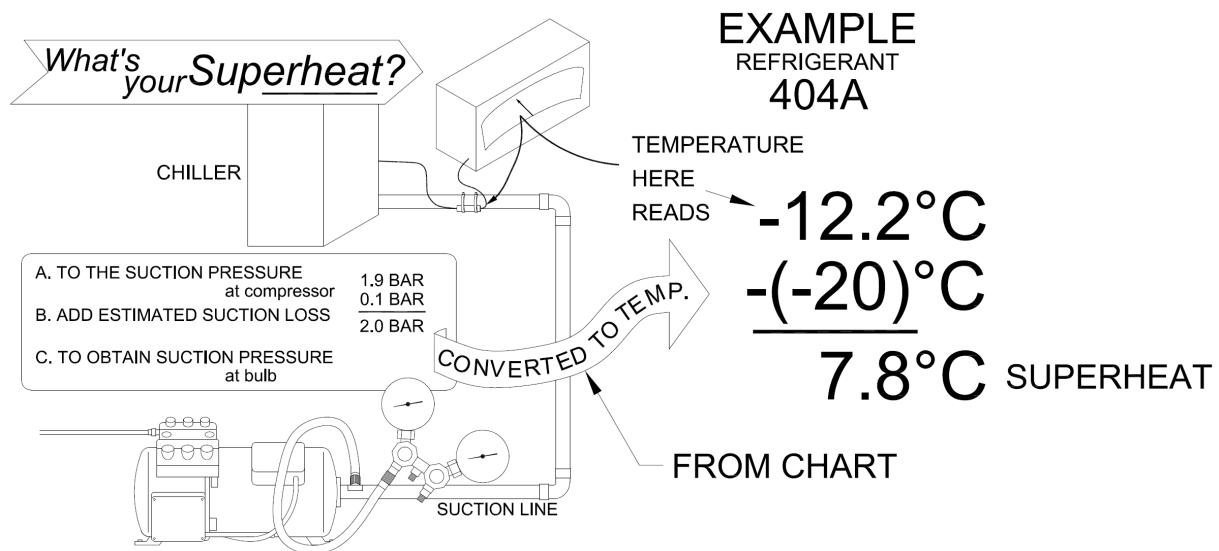

# 5.6 Electrical Schematic

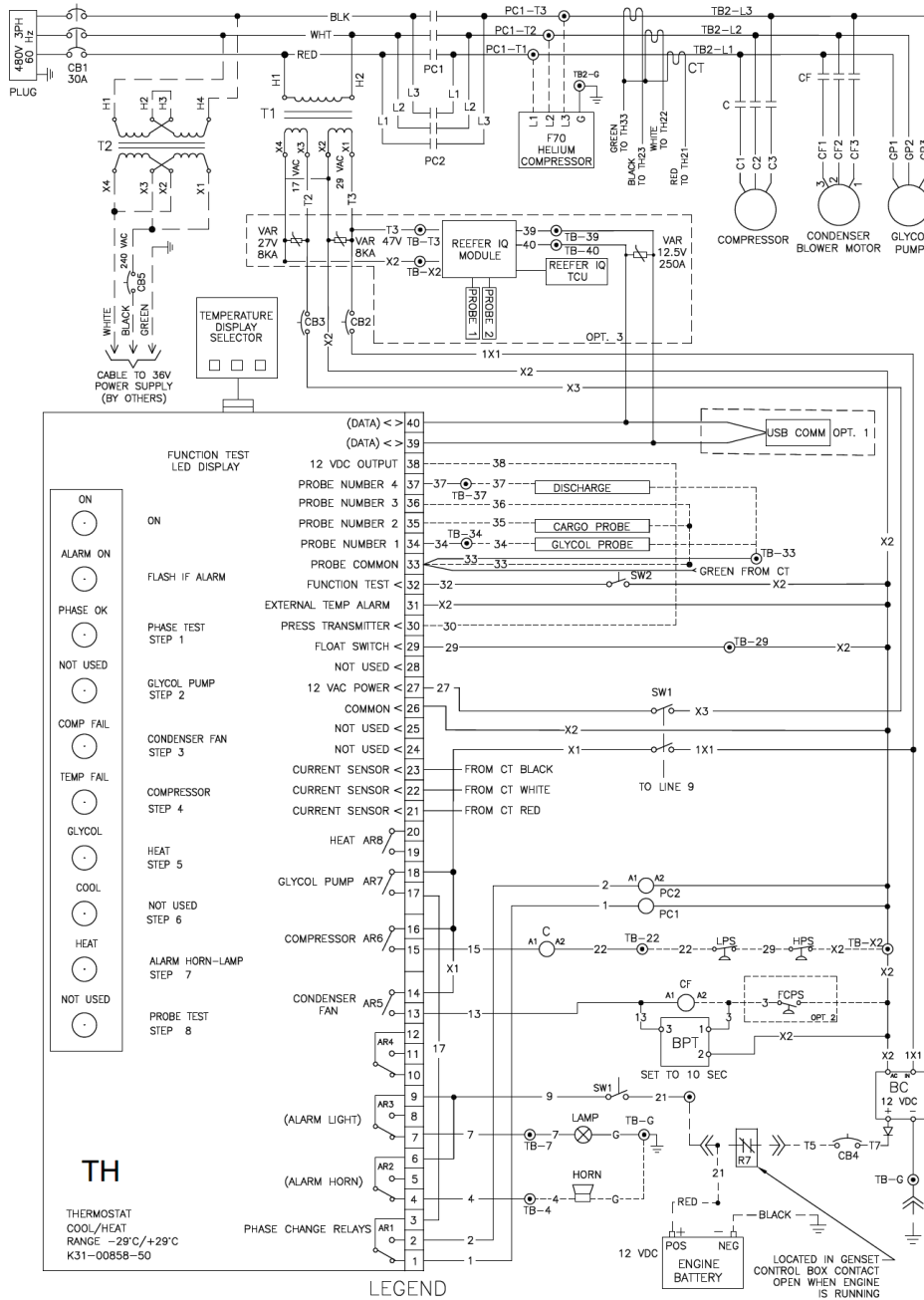

- BAT 12VDC BATTERY
- BC BATTERY CHARGER
- C COMPRESSOR CONTACTOR
- CB1 CIRCUIT BREAKER 30 A (MAIN POWER)
- CB2 CIRCUIT BREAKER 4A (29VAC)
- CB3 CIRCUIT BREAKER 4A (17VAC)
- CB4 CIRCUIT BREAKER 4A (12VDC)
- CB5 CIRCUIT BREAKER 1A (240VAC)
- CF CONDENSER FAN CONTACTOR
- CT CURRENT TRANSFORMER (PHASE 1-2-3)
- FCPS FAN CYCLE PRESSURE SWITCH

- GP GLYCOL PUMP
- HPS HIGH PRESSURE SWITCH
- LPS LOW PRESSURE SWITCH
- PC1 PHASE CHANGING CONTACTOR NO.1
- PC2 PHASE CHANGING CONTACTOR NO.2
- SW1 UNIT ON/OFF (3P)
- SW2 FUNCTION TEST / SET LIMIT SWITCH
- T1 TRANSFORMER 480 - 17/29 VAC
- T2 TRANSFORMER 480 - 240 VAC
- TB TERMINAL BLOCK IN ELECT. BOX
- TH THERMOSTAT (MICROPROCESSOR)
- BPT BYPASS TIMER 10-1000 SEC

- OPTIONS**
- OPTION 1 - DATA LOGGING PC COMMUNICATION
  - OPTION 2 - FAN CYCLE PRESSURE SWITCH
  - OPTION 3 - REEFER IQ

## MODEL TCR-110 MRI

### ELECTRICAL SCHEMATIC WITH OPTIONS

- WIRING INSIDE ELECTRICAL BOX
- - - WIRING OUTSIDE ELECTRICAL BOX
- - - - - OPTIONS
- TERMINAL ACCESS POINT

For technical assistance:  
 Web portal <https://klingscorp.com/request-service>  
 Email: [technical@klingscorp.com](mailto:technical@klingscorp.com)  
 Telephone: +1-717-840-4500  
 For spare parts please email [spares@klingscorp.com](mailto:spares@klingscorp.com)

REV J K35-06700-00

**KLINGE**  
**KLINGE CORPORATION**  
 4075 East Market Street, YORK PA 17402-5100 USA  
[www.klingscorp.com](http://www.klingscorp.com)

## 5.7 Thermostat Operation

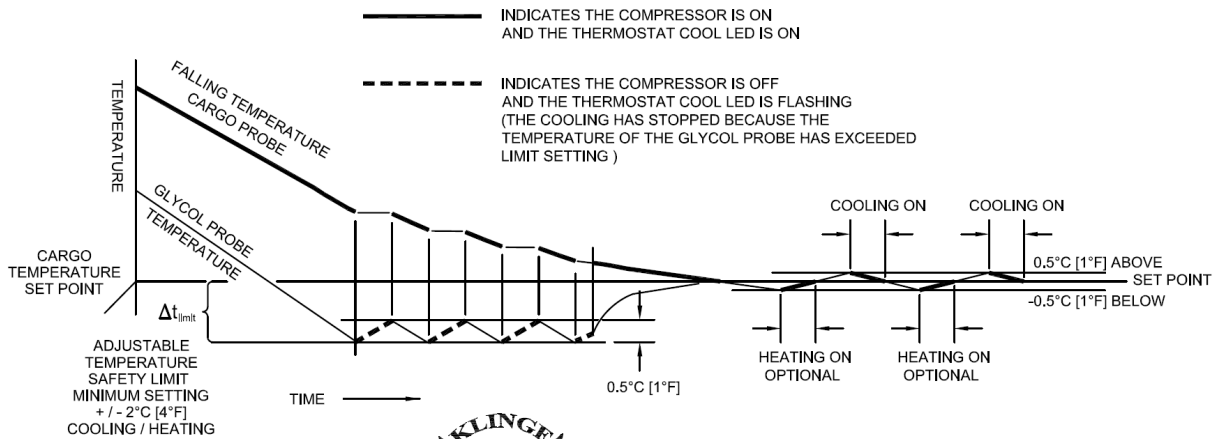

CHART IS SHOWN COOLING  
HEATING IS OPPOSITE  
THE CHART SHOWS THE RELATIONSHIP  
BETWEEN SET POINT, LIMIT AND  
WHICH PROBE (CARGO OR GLYCOL)  
IS CONTROLLING THE UNIT  
COOLING OR HEATING



**NOTE**  
IF THE CARGO PROBE FAILS  
THE GLYCOL PROBE WILL  
CONTROL THE UNIT

### GLYCOL SAFETY LIMIT SETTING

1- THIS IS AN ADJUSTABLE TEMPERATURE LIMIT TO PREVENT THE GLYCOL FROM SUB-COOLING THE CARGO. IT SENSES THE DIFFERENCE FROM THE SET POINT TO THE TEMPERATURE SENSED BY THE GLYCOL PROBE.

2- WHEN THE TEMPERATURE DIFFERENCE IS GREATER THAN THE SAFETY LIMIT THE COOLING OR HEAT WILL SHUT DOWN AND THE THERMOSTAT COOLING OR HEAT LED WILL FLASH.

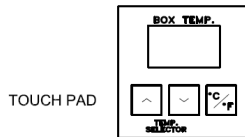

TOUCH PAD



### TOUCH PAD and TEST SWITCH

- 1 - Touch pad shows actual cargo temperature.
- 2 - Push  $\wedge$  or  $\vee$  keys on touch pad to see cargo temperature set point.
- 3 - To see glycol temperature hold the TEST switch down.
- 4 - To see the  $\Delta t$  limit hold the TEST switch down & press  $\wedge$  or  $\vee$  (minimum setting + / - 2°C [4°F])
- 5 - To reset  $\Delta t$  hold the TEST switch down and press  $\wedge$  or  $\vee$  keys then to set the limit simultaneously hold  $\wedge$  and  $\vee$  for 2 seconds.

THERMOSTAT FRONT LED			THERMOSTAT DESCRIPTION WHEN LED IS ON
#	LABEL	LED	
1	ON	ON	12 VOLT POWER TO THE THERMOSTAT
2	ALARM ON	ON	AN ALARM IS PRESENT SEE TOUCH PAD FOR ALARM CODE. REFER TO MANUAL FOR ALARM DESCRIPTION
3	PRIMARY	ON	USED FOR DUAL SYSTEMS ONLY ALWAYS ON WITH A SINGLE UNIT
4	NOT USED	N/A	USED ONLY FOR FUNCTION TEST
5	COMP FAIL	ON	COMPRESSOR HIGH PRESSURE SWITCH OPEN OR DISCHARGE LINE TEMP SWITCH OPEN
6	TEMP FAIL	ON	1- PULL DOWN RATE IS LESS THAN 0.06°C [0.1°F] / HOUR 2- EXTERNAL TEMPERATURE FAULT SEE DATA LOGGER (WHEN USED)
7	GLYCOL	ON	GLYCOL PROBE IS CONTROLLING
		FLASHING	GLYCOL PROBE BAD (CONTROLLING ON CARGO PROBE)
8	COOL	ON	THERMOSTAT IS CALLING FOR COOLING
		FLASHING	COMPRESSOR OFF (GLYCOL TEMPERATURE PROBE IS COLDER THAN THE SAFETY LIMIT SETTING)
9	HEAT (OPTIONAL)	ON	THERMOSTAT IS CALLING FOR HEAT
		FLASHING	HEAT OFF (GLYCOL TEMPERATURE PROBE IS WARMER THAN THE LIMIT SETTING)
10	NOT USED	N/A	USED ONLY FOR FUNCTION TEST

K35-06118-40 REV A GLYCOL SAFETY LIMIT CHART 7/8/16 USE WITH THERMOSTATS K31-00858-40

For example:

If the Cargo set point is +3°C and the Glycol Limit is set to 7, the system will allow the glycol in the system to go as low as -4°C.

The unit will operate in the following manner:

- The Refrigeration Unit would cool the Glycol Temperature down to the  $-4^{\circ}\text{C}$  limit point at which time it would stop cooling and just circulate the glycol.
- If the Cargo is not at the set point temperature, the unit will start cooling again when the Glycol Temperature rises  $1^{\circ}\text{C}$  above the limit. In this case when the Glycol Temp reaches  $-3^{\circ}\text{C}$  it will start cooling again until it reaches  $-4^{\circ}\text{C}$  Glycol or  $3^{\circ}\text{C}$  Cargo Temp.
- If the Cargo Temperature reaches the set point, the unit will not start cooling again until either the Cargo or Glycol Temperature rise  $\frac{1}{2}^{\circ}\text{C}$  degree above the set point. In this case that would be  $3.5^{\circ}\text{C}$ .

## 5.8 Temperature – Pressure Chart

FOR USE WHEN CONVERTING PRESSURE TO TEMPERATURE WHEN CALCULATING THE SUPERHEAT. R-12 ADDED FOR REFERENCE ONLY.

DEGREES FAHRENHEIT	DEGREES CENTIGRADE	R-12 PSIG	R-22 PSIG	R-502 PSIG	R-134A PSIG	R-404A (HP-62) PSIG
-50	-45.6	15.4	6.2	0.2	18.4	0
-48	-44.4	14.6	4.8	0.7	17.7	0.8
-46	-43.3	13.8	3.4	1.5	17	1.6
-44	-42.2	12.9	2	2.3	16.2	2.5
-42	-41.1	11.9	0.5	3.2	15.4	3.4
-40	-40.0	11	0.5	4.1	14.5	5.5
-38	-38.9	10	1.3	5	13.7	6.5
-36	-37.8	8.9	2.2	6	12.8	7.5
-34	-36.7	7.8	3	7	11.8	8.6
-32	-35.6	6.7	4	8.1	10.8	9.7
-30	-34.4	5.5	4.9	9.2	9.7	10.8
-28	-33.3	4.3	5.9	10.3	8.6	12
-26	-32.2	3	6.9	11.5	7.7	13.2
-24	-31.1	1.6	7.9	12.7	6.2	14.5
-22	-30.0	0.3	9	14	4.9	15.8
-20	-28.9	0.6	10.1	15.3	3.6	17.1
-18	-27.8	1.3	11.3	16.7	2.3	18.5
-16	-26.7	2.1	12.5	18.1	0.8	20
-14	-25.6	2.8	13.8	19.5	0.3	21.5
-12	-24.4	3.7	15.1	21	1.1	23
-10	-23.3	4.5	16.5	22.6	1.9	24.6
-8	-22.2	5.4	17.9	24.2	2.8	26.3
-6	-21.1	6.3	19.3	25.8	3.6	28
-4	-20.0	7.2	20.8	27.5	4.5	29.8
-2	-18.9	8.2	22.4	29.3	5.5	31.6
0	-17.8	9.2	24	31.1	6.5	33.5
2	-16.7	10.2	25.6	32.9	7.5	34.8
4	-15.6	11.2	27.3	34.9	8.5	37.4
6	-14.4	12.3	29.1	36.9	9.6	39.4
8	-13.3	13.5	30.9	38.9	10.8	41.6
10	-12.2	14.6	32.8	41	12	43.7
12	-11.1	15.8	34.7	43.2	13.1	46
14	-10.0	17.1	36.7	45.4	14.4	48.3
16	-8.9	18.4	38.7	47.7	15.7	50.7
18	-7.8	19.7	40.9	50	17	53.1
20	-6.7	21	43	52.5	18.4	55.6
22	-5.6	22.4	45.3	54.9	19.9	58.2
24	-4.4	23.9	47.6	57.5	21.4	60.9
26	-3.3	25.4	49.9	60.1	22.9	63.6
28	-2.2	26.9	52.4	62.8	24.5	66.5
30	-1.1	28.5	54.9	65.6	26.1	69.4
32	0.0	30.1	57.5	68.4	27.8	72.3
34	1.1	31.7	60.1	71.3	29.5	75.4
36	2.2	33.4	62.8	74.3	31.3	78.5
38	3.3	35.2	65.6	77.4	33.2	81.8
40	4.4	36.9	68.4	80.5	35.1	85.1
42	5.6	38.8	71.3	83.8	37	88.5
44	6.7	40.7	74.5	87	39.1	91.9
46	7.8	42.7	77.6	90.4	41.1	95.5
48	8.9	44.7	80.7	93.9	43.3	99.2
50	10.0	46.7	84	97.4	45.5	102.9

DEGREES FAHRENHEIT	DEGREES CENTIGRADE	R-12 PSIG	R-22 PSIG	R-502 PSIG	R-134A PSIG	R-404A (HP-62) PSIG
52	11.1	48.8	87.3	101	47.7	109
54	12.2	51	90.8	104.8	50.1	113
56	13.3	53.2	94.3	108.6	52.3	117
58	14.4	55.4	97.9	112.4	55	121
60	15.6	57.7	101.6	116.4	57.5	125
62	16.7	60.1	105.4	120.4	60.1	130
64	17.8	62.5	109.3	124.6	62.7	134
66	18.9	65	113.2	128.8	65.5	139
72	22.2	72.9	125.7	142.2	74.2	153
74	23.3	75.6	130	146.8	77.2	158
76	24.4	78.4	134.5	151.5	80.3	164
78	25.6	81.3	139	156.3	83.5	169
80	26.7	84.2	143.6	161.2	86.8	174
82	27.8	87.2	148.4	166.2	90.2	180
84	28.9	90.2	153.2	171.4	93.6	185
86	30.0	93.3	158.2	176.6	97.1	191
88	31.1	96.5	163.2	181.9	100.7	197
90	32.2	99.8	168.4	187.4	104.4	203
92	33.3	103.1	173.7	192.9	108.2	209.9
94	34.4	106.5	179.1	198.6	112.1	215
96	35.6	110	184.6	204.3	116.1	222
98	36.7	113.5	190.2	210.2	120.1	229
100	37.8	117.2	195.9	216.2	124.3	235
102	38.9	120.9	201.8	222.3	128.5	242
104	40.0	124.7	207.7	228.5	132.9	249
106	41.1	128.5	213.8	234.9	137.3	256
108	42.2	132.4	220	241.3	142.8	264
110	43.3	136.4	226.4	247.9	146.5	271
112	44.4	140.5	232.8	254.6	151.3	279
114	45.6	144.7	239.4	261.5	156.1	286
116	46.7	148.9	246.1	268.4	161.1	294
118	47.8	153.2	252.9	275.5	166.1	302
120	48.9	157.7	259.9	282.7	171.3	311
122	50.0	162.2	267	290.1	176.6	319
124	51.1	166.7	274.3	297.6	182	328
126	52.2	171.4	281.6	305.2	187.5	336
128	53.3	176.2	289.1	312.9	193.1	345
130	54.4	181	296.8	320.8	198.9	354
132	55.6	185.9	304.6	328.9	204.7	364
134	56.7	191	312.5	337.1	210.7	373
136	57.8	196.1	320.6	345.4	216.8	383
138	58.9	201.3	328.9	353.9	223	392
140	60.0	206.6	337.3	362.6	229.4	402
142	61.1	212	345.8	371.4	235.8	413
144	62.2	217.5	354.5	380.4	242.4	423
146	63.3	223.1	363.3	389.5	249.2	434
148	64.4	228.8	372.3	398.9	256	444
150	65.6	234.6	381.5	408.4	263	449

**NOTE: THE USE OF ANY REFRIGERANT NOT SPECIFICALLY DESIGNATED BY THE MANUFACTURER MAY VOID THE WARRANTY.**

## **SECTION SIX – TCR-110 SERVICE PARTS**

- 6.1 Unit refrigeration outside view
- 6.2 Unit refrigeration with covers removed
- 6.3 Unit pump assembly
- 6.4 Blower and motor assembly
- 6.5 Refrigeration unit parts and piping schematic
- 6.6A Small electrical control box, dual probes
- 6.6B Small electrical control box, cable hook-up, heater, float switch & dual probes
- 6.6C Junction box for small electrical box
- 6.7A Spare Parts Kit
- 6.7B Spare Parts Misc
- 6.8 ST9100 Junction Box

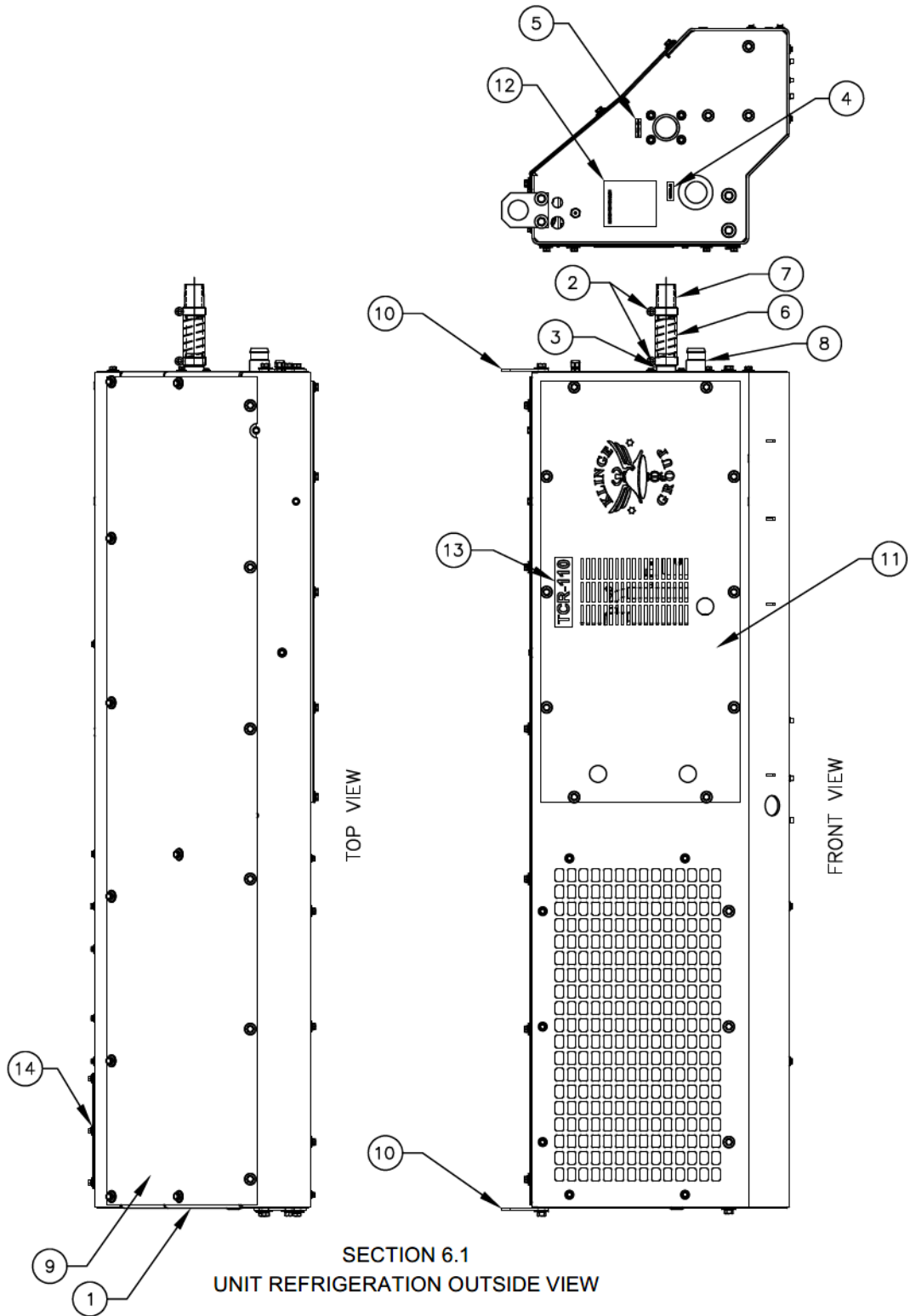

**SECTION 6.1****UNIT REFRIGERATION OUTSIDE VIEW**

<b>ITEM</b>	<b>PART NO.</b>	<b>DESCRIPTION</b>	<b>QTY.</b>
1	460 18110 00	UNIT GLYCOL	1
2	K21 16379 05	CLAMP CONSTANT TORQU SS 1-1/16	2
3	K23 13248 04	NIPPLE SS 1-1/4NPT SCH80 4	1
4	K35 05896 00	LABEL GLYCOL IN	1
5	K35 05897 00	LABEL GLYCOL OUT	1
6	060 12592 05	TUBE PVC CLEAR W/WIRE 1.5"Dx9"	1
7	060 12812 01	CONNECTION PUMP INLET 3" LONG	1
8	060 12812 02	CONNECTION PUMP INLET 11" LONG	1
9	060 18014 01	HOUSING TOP COVER TCR-110 WHITE	1
10	060 13153 00	BRACKET LIFTING	2
11	360 18012-02	PANEL FRONT ASSEMBLY	1
12	K35-05803-01	LABEL DATA PLATE MODIFIED	1
13	K35-06603-01	LABEL TCR-110	1
14	360-18072-02	PANEL ACCESS COND MOTOR W/GASKET	1

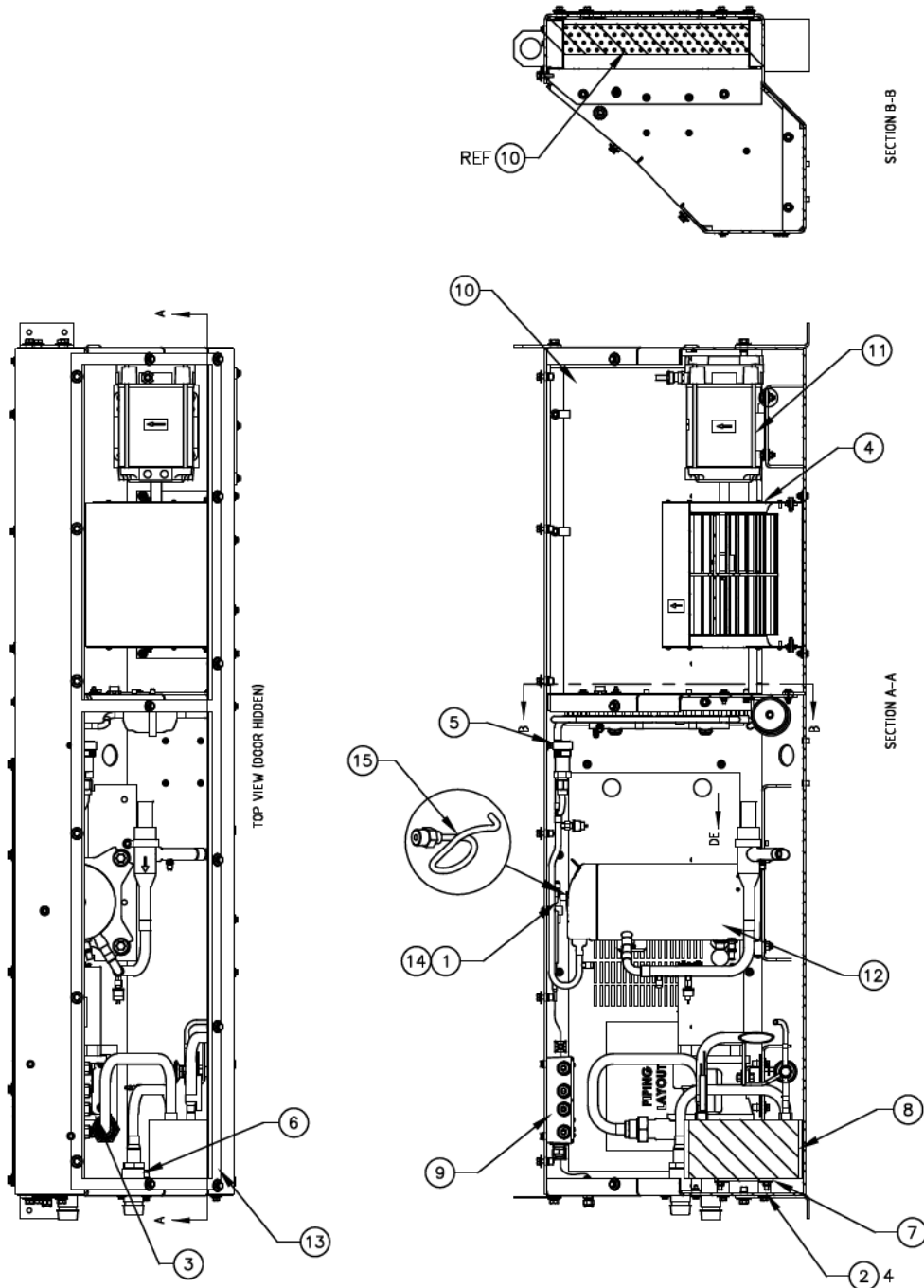

SECTION 6.2  
 UNIT REFRIGERATION  
 W / COVERS REMOVED

**SECTION 6.2****UNIT REFRIGERATION W/COVERS  
REMOVED**

<b>ITEM</b>	<b>PART NO.</b>	<b>DESCRIPTION</b>	<b>QTY.</b>
1	K15-00042-04	KIT VALVE DTC DISCH TEMP CONTROL	1
2	060-13189-00	SPACER CHILLER MTG	4
3	360-18114-10	PUMP MODIFICATION 1 HP	1
4	360-12897-40	BLOWER ASSEMBLY	1
5	K22-07028-03	VALVE PRESSURE RELIEF 475 PSI	1
6	360-13154-00	ASSEMBLY PLATE GLYCOL OUTLET	1
7	360-18024-00	PLATE CHILLER MTG W/NUT INSERTS	1
8	360-18025-00	CHILLER W/INSULATION	1
9	360-12944-40	JUNCTION BOX ASSEMBLY	1
10	360-18010-00	ASSEMBLY COIL CONDENSER	1
11	360-18054-01	CONDENSER MOTOR ASSEMBLY W/CABLE	1
12	360-18116-00	COMPRESSOR SCROLL W/CABLE	1
13	060-13229-10	GASKET TOP COVER	1
14	K15-00042-07	O-RING DTC VALVE (INCLUDED WITH ITEM 1)	1
15	360-18016-00	TUBE ¼ DTC VALVE TO COMPRESSOR	1

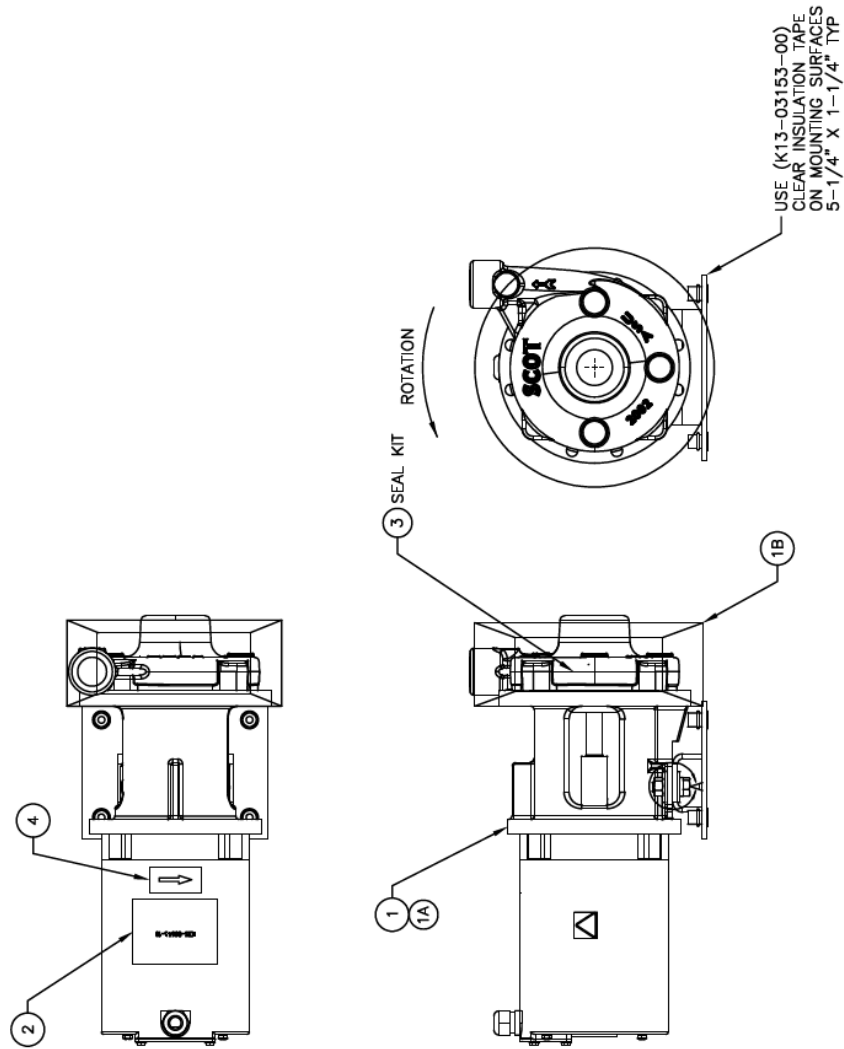

SECTION 6.3  
UNIT PUMP ASSEMBLY

**SECTION 6.3****UNIT PUMP ASSEMBLY**

<b>ITEM</b>	<b>PART NO.</b>	<b>DESCRIPTION</b>	<b>QTY.</b>
1	360-18114-10	MOTOR - PUMP - MOUNTING BRACKET,	1
		INSULATION AS COMPLETE "DROP IN"	
		REPLACEMENT PART	
1A	K26-25329-11	PUMP GLYCOL PAINTED 1 HP	1
1B	060-12543-00	INSULATION	1
2	K35-06645-10	LABEL PUMP INFORMATION	1
3	K26-25035-00	REPLACEMENT SEAL KIT	1
4	K35-05606-00	LABEL ARROW	1

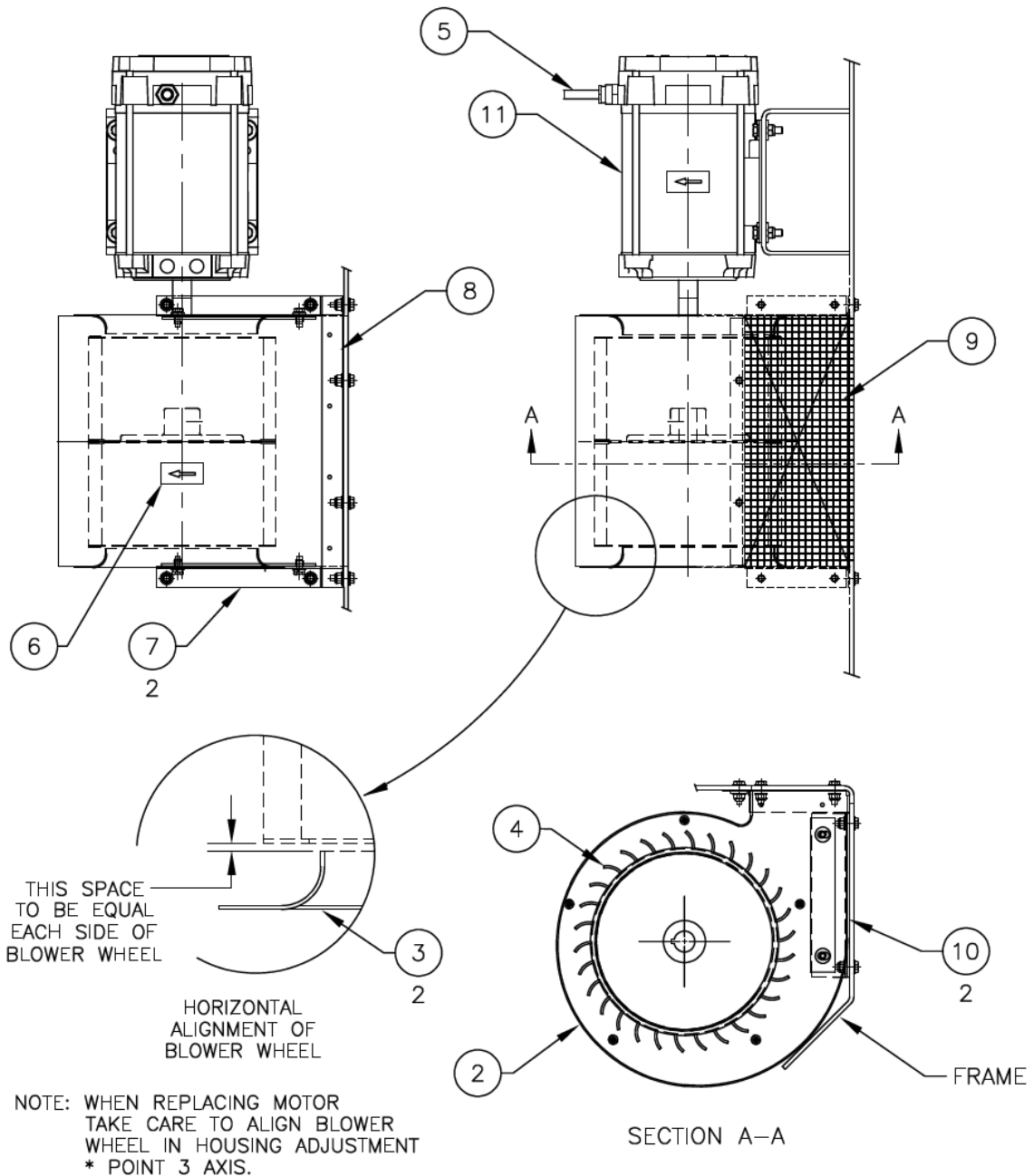

SECTION 6.4  
BLOWER & MOTOR ASSEMBLY

**SECTION 6.4****BLOWER & MOTOR ASSEMBLY**

<b>ITEM</b>	<b>PART NO.</b>	<b>DESCRIPTION</b>	<b>QTY.</b>
1	360-12897-40	BLOWER ASSEMBLY	1
2	K26-25059-40	HOUSING BLOWER	1
3	K26-25060-00	RING INLET CONE	2
4	K26-25061-00	WHEEL BLOWER DOUBLE INLET	1
5	360-18055-01	CABLE CONDENSER FAN TO JUNCTION BOX	1
6	K35-05606-00	LABEL ARROW 1" X 2"	1
7	060-12864-00	SUPPORT BLOWER TCR	2
8	360-18037-00	PLATE BLOWER DISCHARGE ASSEMBLY	1
9	060-12878-01	SCREEN DISCHARGE AIR	1
10	360-12943-00	PLATE NUT LOWER	2
11	360-18054-01	CONDENSER MOTOR ASSEMBLY	1

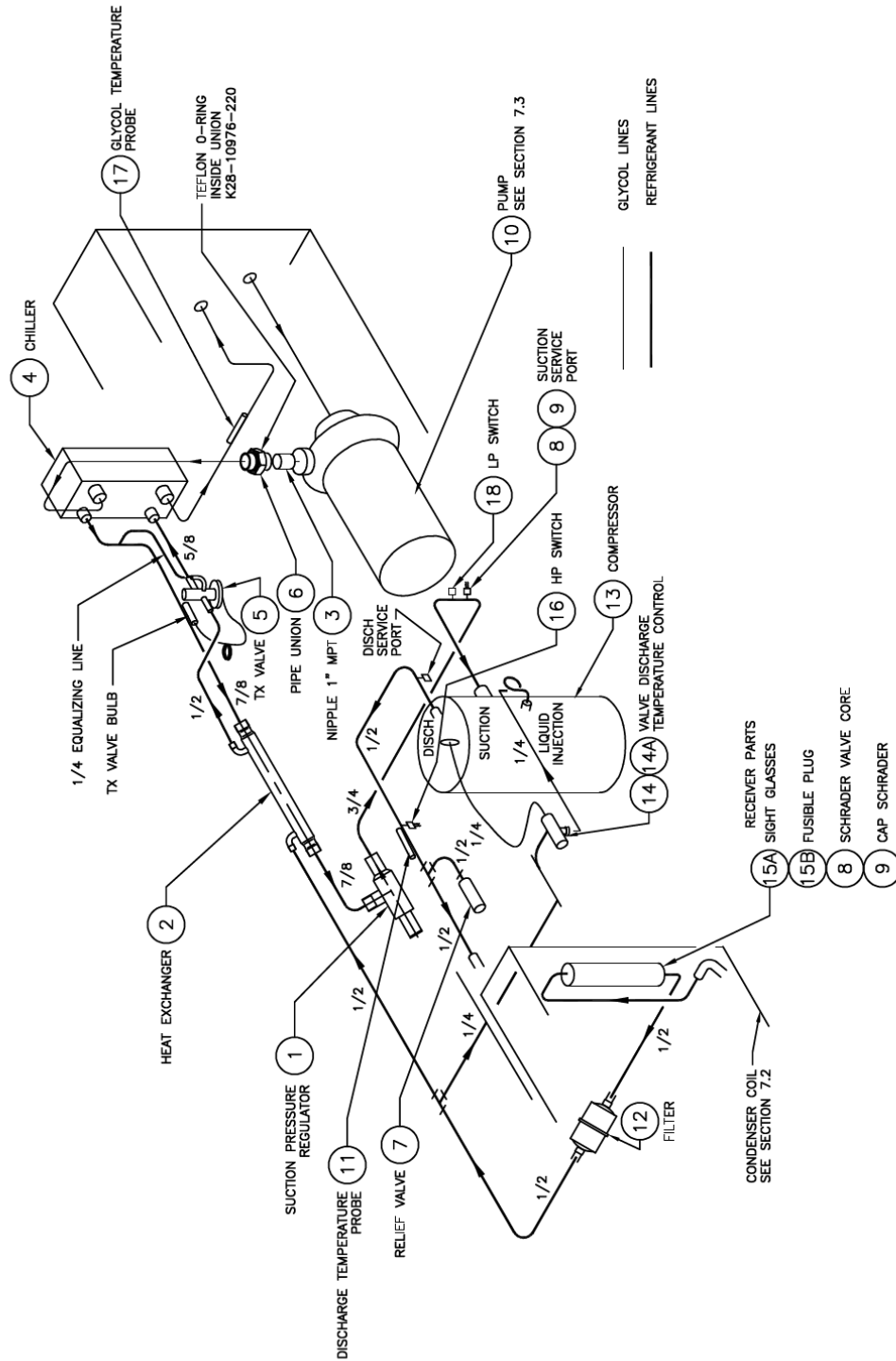

SECTION 6.5  
REFRIGERATION UNIT PARTS  
& PIPING SCHEMATIC

**SECTION 6.5**

**REFRIGERATION UNIT PARTS & PIPING  
SCHEMATIC**

<b>ITEM</b>	<b>PART NO.</b>	<b>DESCRIPTION</b>	<b>QTY.</b>
1	K22-07038-01	VALVE SUCTION PRESS REGULATOR	1
2	K26-17451-01	HEAT EXCHANGER	1
3	K23-13228-06	NIPPLE 1" MPT SCH40 1-1/2" LG	1
4	360-18025-00	CHILLER BOLTS ON BACK W/INSULATION	1
5	K25-26975-00	VALVE TX 3 TON R-134a	1
6	K23-13259-06	UNION PIPE SS 150# 1FPT	1
7	K22-07028-01	VALVE RELIEF (425 PSIG)	
8	K22-02475-00	CORE VALVE CHARGE PORT	3
9	K23-09797-00	CAP FLARE KNURLED ¼ PLASTIC	3
10	360-18114-10	PUMP ASSEMBLY SEE SECTION 6.3	1
11	360-18113-00	PROBE DISCHARGE TEMPERATURE	1
12	K26-10795-01	FILTER DRIER 1/2C	1
13	360-18116-00	COMPRESSOR ASSEMBLY W/CABLE	1
14	K15-00042-04	KIT VALVE DISCHARGE TEMPERATURE CONTROL	1
14A	K15-00042-07	O-RING DTC VALVE FOR SCROLL COMPRESSOR	1
15A	K26-25031-00	SIGHT PLUG W/BALLS AND MOISTURE INDICATOR	1
		INCLUDED IN ITEM 10 OF SECTION 6.2	
15B	K23-06100-00	PLUG FUSIBLE 1/8 MPT 212°F	1
		INCLUDED IN ITEM 10 OF SECTION 6.2	
16	360-18112-00	SWITCH PRESSURE NC OPEN AT 450 PSI	1
17	360-18132-00	PROBE GLYCOL	1

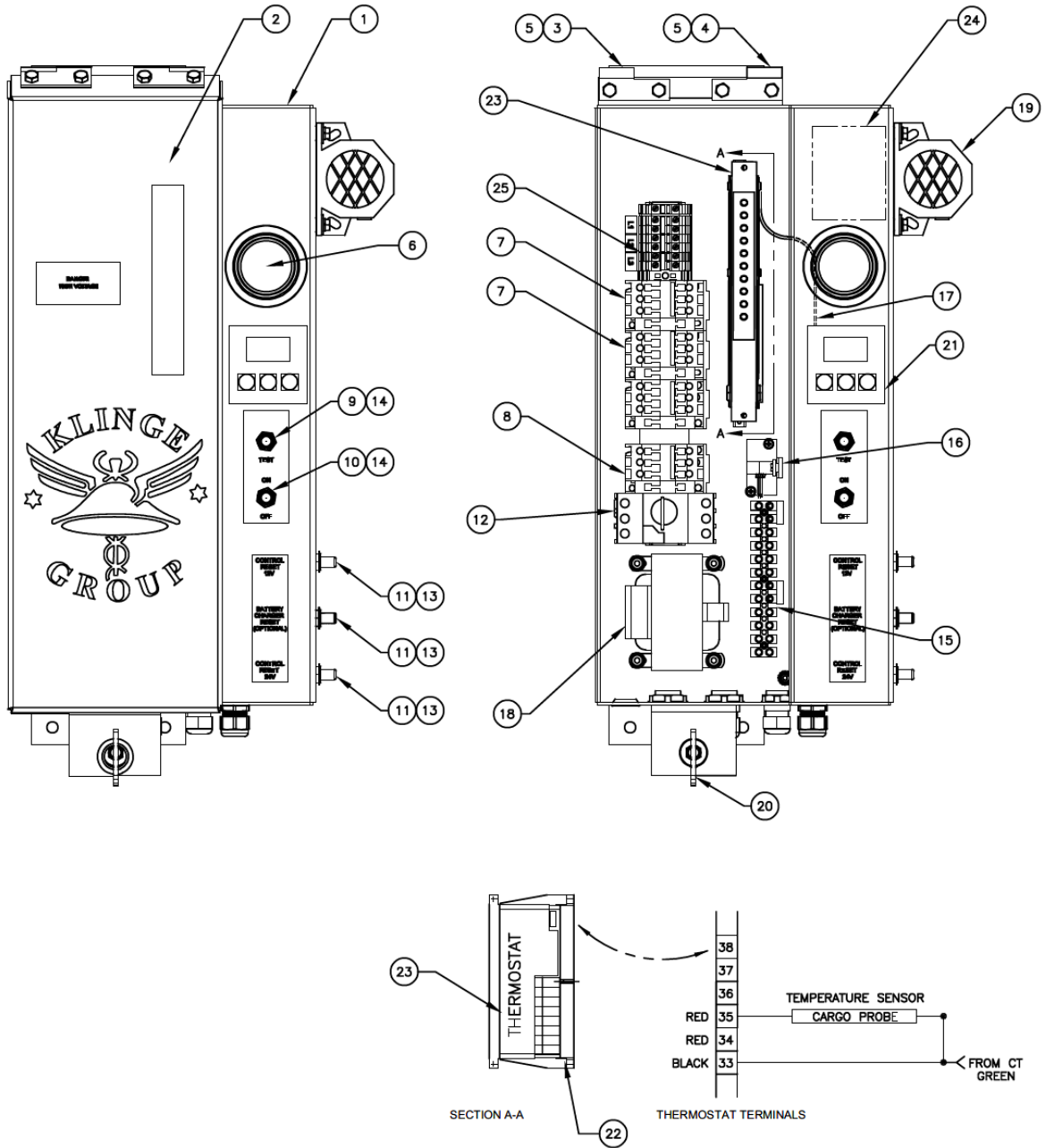

SECTION 6.6A  
 SMALL ELECTRICAL CONTROL BOX  
 WITH PROBES

## SECTION 6.6A

SMALL ELECTRICAL CONTROL BOX  
WITH PROBES

ITEM	PART NO.	DESCRIPTION	QTY.
1	460 18402 00	ASSEMBLY STANDARD ELEC BOX SMALL	1
2	360 18403 00	DOOR ELECTRICAL BOX TCR SMALL	1
3	K29 17879 01	HINGE SLIP SS 9/32 HOLES SOCK RIGHT-HAND	1
4	K29 17880 01	HINGE SLIP SS 9/32 HOLES SOCK LEFT-HAND	1
5	060 09113 00	INSULATOR HINGE	2
6	360 17648 00	LAMP ALARM ASSY TCR/TRS SMALL	1
7	K24 22155 00	CONTACTOR 9A 3P 24V 60/50 HZ COIL	2
8	K24 22329 00	CONTACTOR REVERSING 30A 3P 24V 50/60	1
9	K24 22152 00	SWITCH TOGGLE SPDT MOM *ON-OFF-*ON	1
10	K24 22144 00	SWITCH TOGGLE 3PST ON-OFF #6 SCR	1
11	K24 22330 00	CIRCUIT BREAKER 4 AMP 1 POLE 1/4PO PANEL MT	3
12	K24 22363 32	CIRCUIT BREAKER IEC 3POLE 24-32 AMP	1
13	K24 18164 00	BOOT CIRCUIT BREAKER 3/8-27 THREAD ACCORD	3
14	K24 17239 00	BOOT TOGGLE SW	2
15	K25 26488 12	BLOCK TERMINAL STRIP 12P 45A 8-18 GA	1
16	360 16398 00	CURRENT SENSING TRANSFORMER 20A 3PH VERTICAL	1
17	360 12540 05	CABLE RIBBON SHLD 13` 10 WIRES 13LG	1
18	K25 26624 10	TRANSFORMER 230 V 400V 24V/12V	1
19	360-13349-11	HORN ASSEMBLY PULSATING	1
20	K21 16313 00	FASTENER BABY ANTILUSE M8x1.25	1
21	K31 00811 00	DISPLAY TEMP W/SELECTOR F/C	1
22	360 10829 00	BASE THERMOSTAT	1
23	K31 00858 50	THERMOSTAT W/ LABELS TCR SMALL	1
24	360 15580 01	BATTERY CHARGER MODIFIED 24 VAC 12 VDC 3 AMP	1
25	K25 26739 15	TERMINAL UT6	6

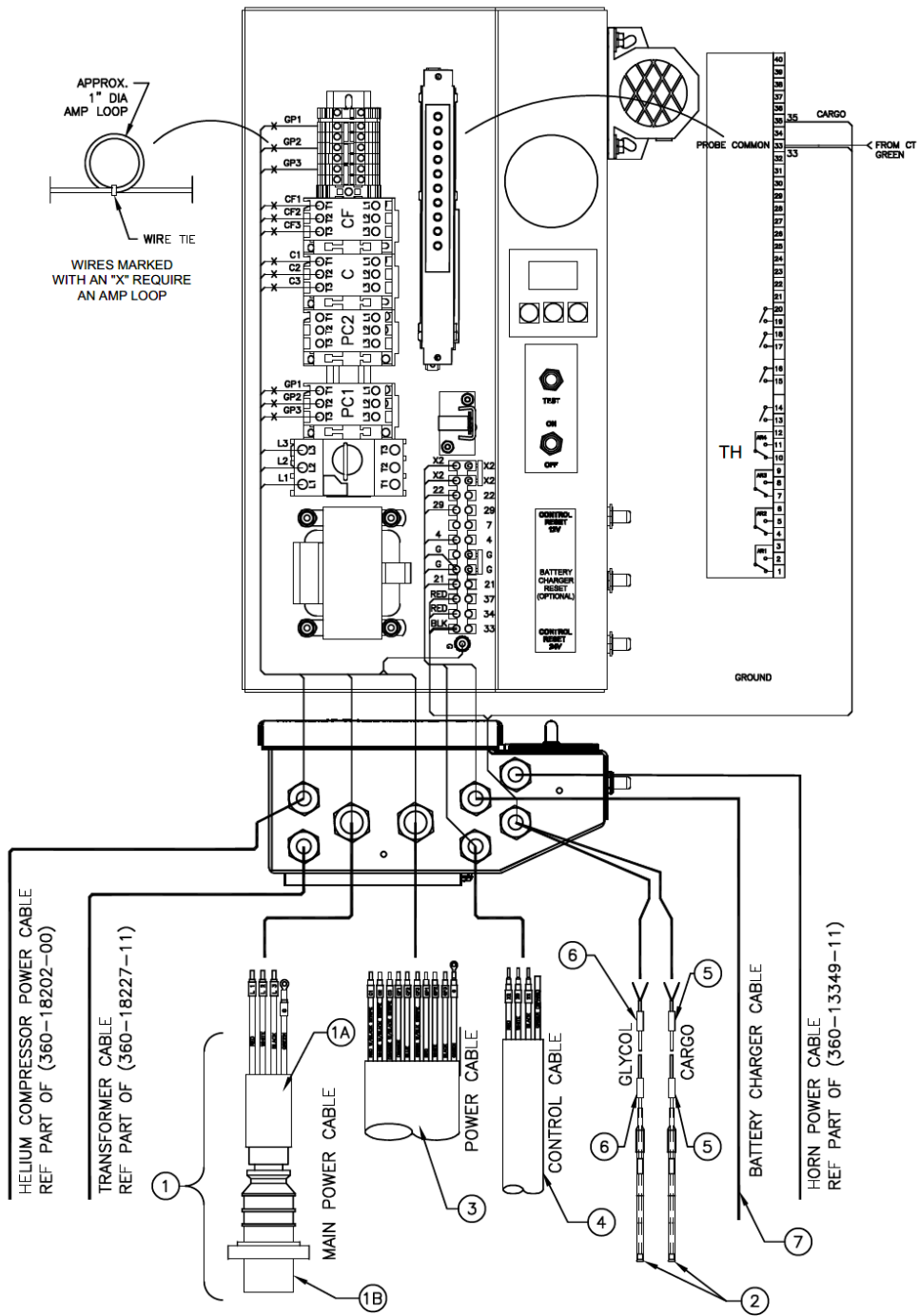

SECTION 6.6B  
 SMALL ELECTRICAL CONTROL BOX  
 CABLE HOOK-UP AND PROBES

**SECTION 6.6B****SMALL ELECTRICAL CONTROL BOX  
CABLE HOOK-UP & PROBES**

<b>ITEM</b>	<b>PART NO.</b>	<b>DESCRIPTION</b>	<b>QTY.</b>
1	360 17648 01	CABLE ASSEMBLY MAIN POWER TCR 64 FT	1
1A	K25-19623-00	CORD ELECTRICAL SOOW 10/4 64' LG	1
1B	K25 20474 00	PLUG POWER 32A 380/440V 3P+G WATER TIGHT	1
2	K25 26097 00	PROBE TEMPERATURE .31 DIAx6"LGx 13 FT	2
3	360 17648-08	CABLE POWER TCR ELEC BOX TO UNIT	1
4	360 17648-07	CABLE CONTROL TCR ELEC BOX TO UNIT	1
5	K25 26120 28	MARKER WIRE .25 ID CARGO	2
6	K25 26120 29	MARKER WIRE .25 ID GLYCOL	2
7	360 17648 09	CABLE BATTERY CHARGER	1

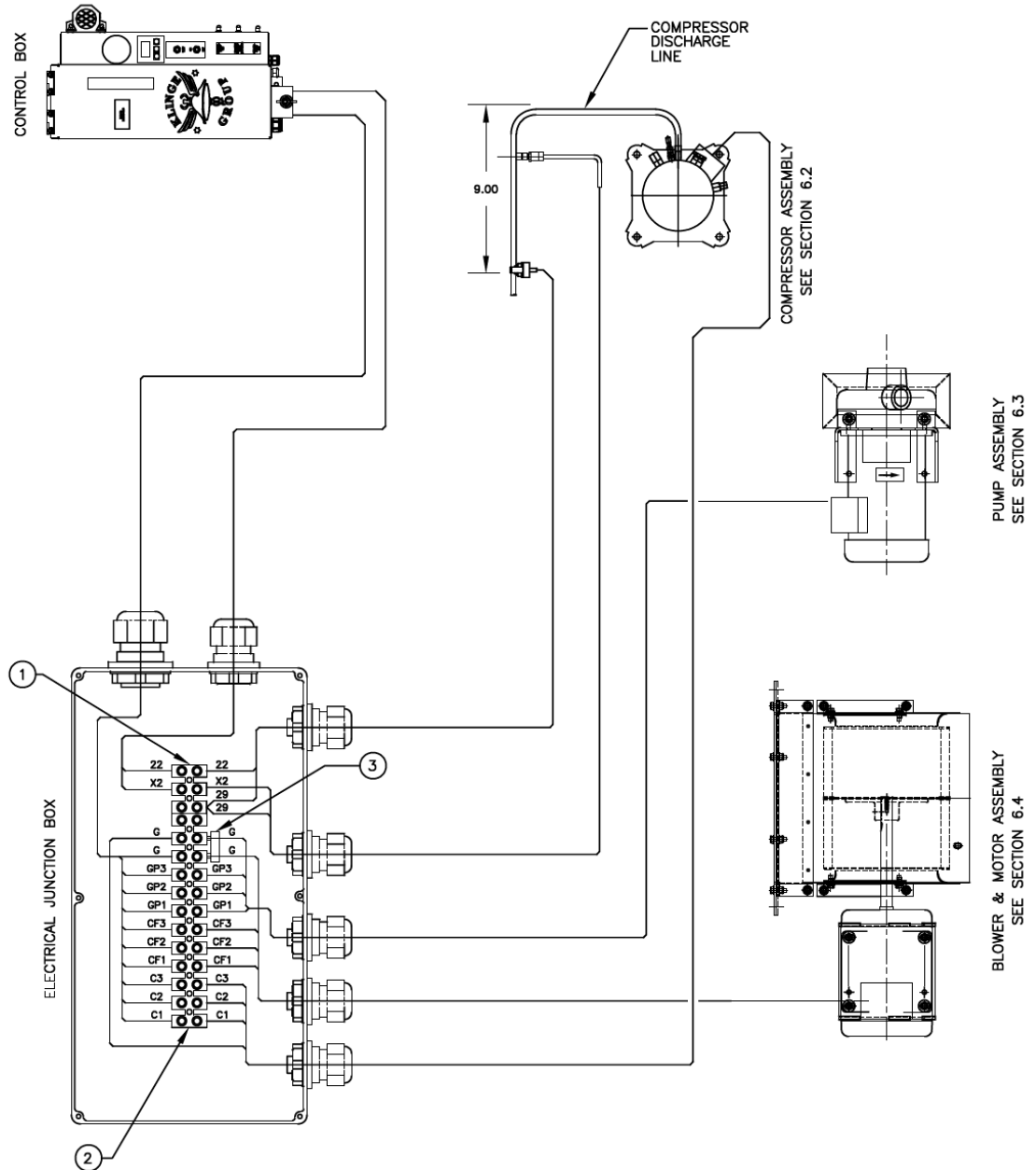

SECTION 6.6C  
 JUNCTION BOX TCR 110  
 FOR SMALL ELECTRICAL BOX

**SECTION 6.6C****JUNCTION BOX TCR-110  
FOR SMALL ELECTRICAL BOX**

<b>ITEM</b>	<b>PART NO.</b>	<b>DESCRIPTION</b>	<b>QTY.</b>
1	K25-26488-03	TERMINAL STRIP 3 POLE 45A 8-18GA #4-40	1
2	K25-26488-12	TERMINAL STRIP 12 POLE 45A 8-18GA #4-40	1
3	K25-26550-02	JUMPER TERM STRIP 8-18GA #4-40	1



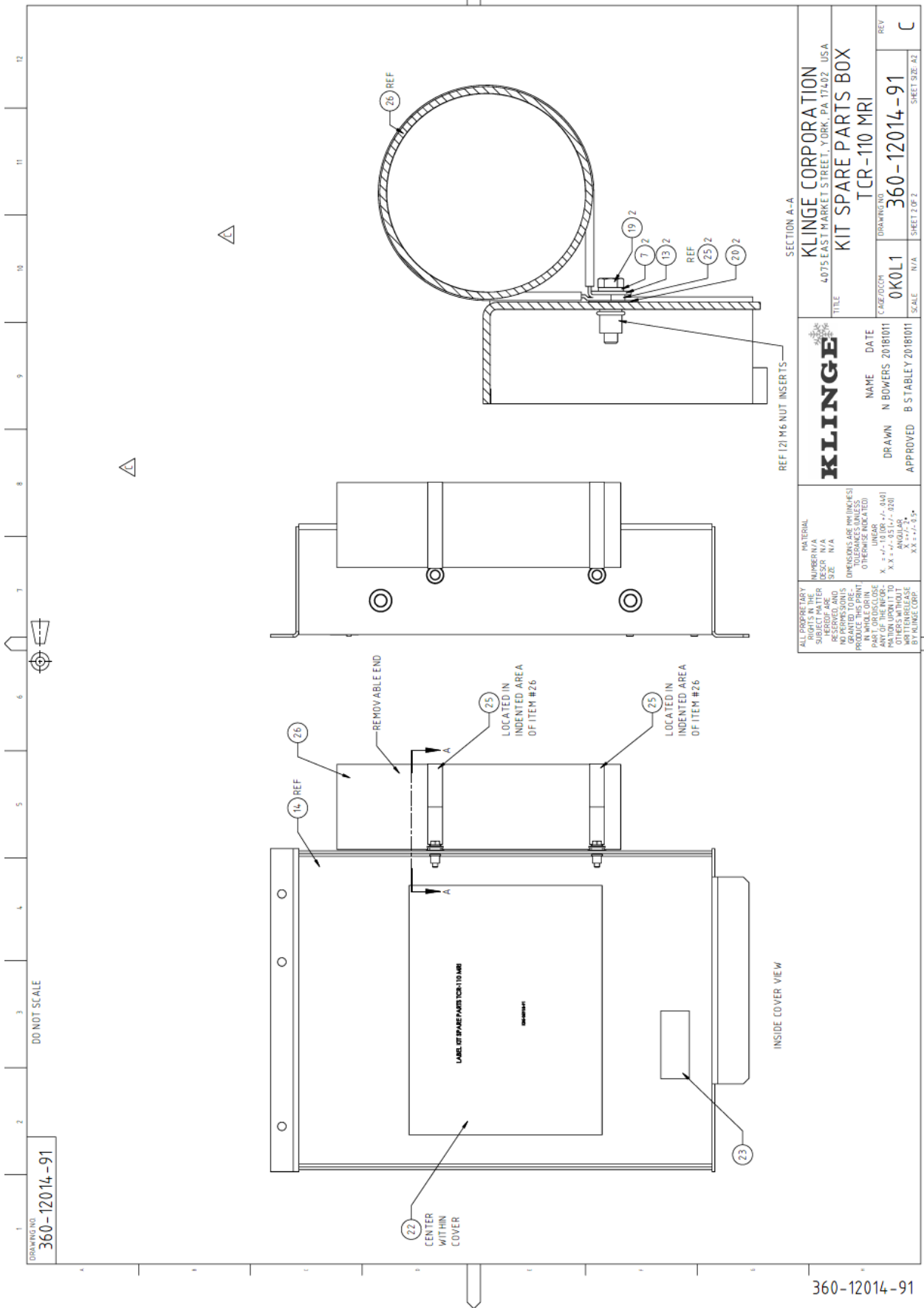

DRAWING NO  
360-12014-91

DO NOT SCALE

INSIDE COVER VIEW

SECTION A-A  
REF 121 M6 NUT INSERTS

<b>KLINGE</b> KLINGE CORPORATION 4075 EAST MARKET STREET, YORK, PA 17402, USA		TITLE <b>KIT SPARE PARTS BOX</b> TCR-110 MRI	
DRAWN N BOWERS	DATE 2018/01/11	DRAWING NO 360-12014-91	REV C
APPROVED B STABLEY	MATERIAL NUMBER/A DESCR N/A QTY N/A	NAME N BOWERS	SCALE N/A
ALL PROPRIETARY RIGHTS IN THE SOFTWARE AND HARDWARE ARE RESERVED AND WILL BE PROTECTED BY PATENT. PERMISSION IS GRANTED TO REPRODUCE THIS PRINT FOR PERSONAL USE ONLY. PART OR DISCLOSE ANY OF THE INFO. TO OTHERS WITHOUT WRITTEN RELEASE BY KLINGE CORP.		DIMENSIONS ARE IN (INCHES) LINEAR X ± .010 (OR ±.010) X ± .005 (OR ±.005) ANGULAR X ± .1° (OR ±.1°)	SHEET 2 OF 2

360-12014-91

UNCONTROLLED IF PRINTED

# 6.7B Spare Parts Misc

REV DATE DESCRIPTION CHANGE NO DRAWN APPROVED

A 20200707 ITEM #6 WAS K25-26929-00, ITEM #7 WAS K25-26095-00, ITEM #12 WAS K31-00858-40 20-257 DBG BES

ITEM	PART NO	DESCRIPTION	QTY
21	K28-10785-01	BOOT CIRCUIT BREAKER	1
20	X8-998208	SWITCH LOW OIL PRES NC ISUZU OPENS AT P=14 PSI	1
19	K24-22721-01	RELAY 12 VDC SPDT 30/40 AMP	1
18	K24-18164-00	BOOT CKT BRK 3/8-27 THD CLEAR	2
17	K24-17239-00	BOOT TGL SW FULL IP 66/68	2
16	360-10829-00	BASE THERMO GREEN 5 PIECE WITH LABELS	1
15	K31-00811-00	DISPLAY TEMP AND SELECTOR F/C	1
14	360-12540-05	CABLE RIBBON SHLD 10 WIRES	1
13	360-16398-00	CURRENT SENSING TRANSFORMER 20A 3PH VERTICAL	1
12	K31-00858-50	THERMOSTAT MPC-4, CONTROLLER	1
11	K24-22330-00	CKT BKR 4 AMP 1POLE 1/4 PO PANEL MTG	1
10	360-15580-01	BATTERY CHARGER MODIFIED 24 VAC 12 VDC 3 AMP	1
9	360-17984-02	CABLE DOWNLOAD DATA TO PC FROM MPC4 CONTROLLER	1
8	360-17984-01	CABLE DOWNLOAD DATA FROM MPC4 TO PC BOX END	1
7	360-18463-00	SWITCH HP NC OPEN 350 CLOSE 250 PSIG WITH RECEP	1
6	360-18155-01	SWITCH LP ASSY NC OPENS AT 5 PSI CLOSURES AT 20 PSI	1
5	K24-22152-00	SWITCH TGL SPDT MON *ON-OFF-xON #6 13/16 SCR	1
4	K24-22144-00	SWITCH TGL 3PST ON-OFF #6 SCR	1
3	K22-07028-03	VALVE RELIEF 1/2 MPT X 3/4 MPT (475 PSIG)	1
2	360-13807-00	KIT PROBE UNIVERSAL	1
1	K30-00082-00	CARTON 11-1/4 X 8-3/4 X 4	1

360-11213-91

- NOTES:
- CARTON MAY HAVE TO BE SLIT TO FIT INSIDE SPARE PARTS BOX.
  - SOME PARTS MAY HAVE TO BE REMOVED FROM THEIR BOXES, AND PUT INTO MARKED PLASTIC BAGS TO FIT INTO CARTON.
  - USE PACKING AS REQUIRED.

ALL PROPRIETARY RIGHTS IN THE SUBJECT MATTER HEREOF ARE RESERVED. NO WARRANTIES OR WARRANTIES OF MERCHANTABILITY ARE GRANTED TO REPRODUCE THIS PRINT, IN WHOLE OR IN PART, OR DISCLOSE ANY INFORMATION CONTAINED HEREIN TO OTHERS WITHOUT WRITTEN RELEASE BY KLINGE CORP.

MATERIAL NUMBER N/A  
DESCR N/A  
SIZE N/A  
DIMENSIONS IN INCHES  
TOLERANCES (UNLESS OTHERWISE SPECIFIED)  
LINEAR .0005"  
ANGULAR .005"  
X<sub>s</sub> = +.10 (-0.17, .000)  
X<sub>y</sub> = +.005"  
X<sub>z</sub> = +.005"

UNCONTROLLED IF PRINTED

**KLINGE CORPORATION**  
407E EAST MARKET STREET, YORK, PA 17402 USA

**BOX SPARE PARTS MISC**

DATE 10/11/18  
DRAWN N BOWERS  
APPROVED B STABLEY

TITLE  
DRAWING NO  
SCALE  
SHEET 1 OF 1

REV  
REV  
REV

360-11213-91  
A

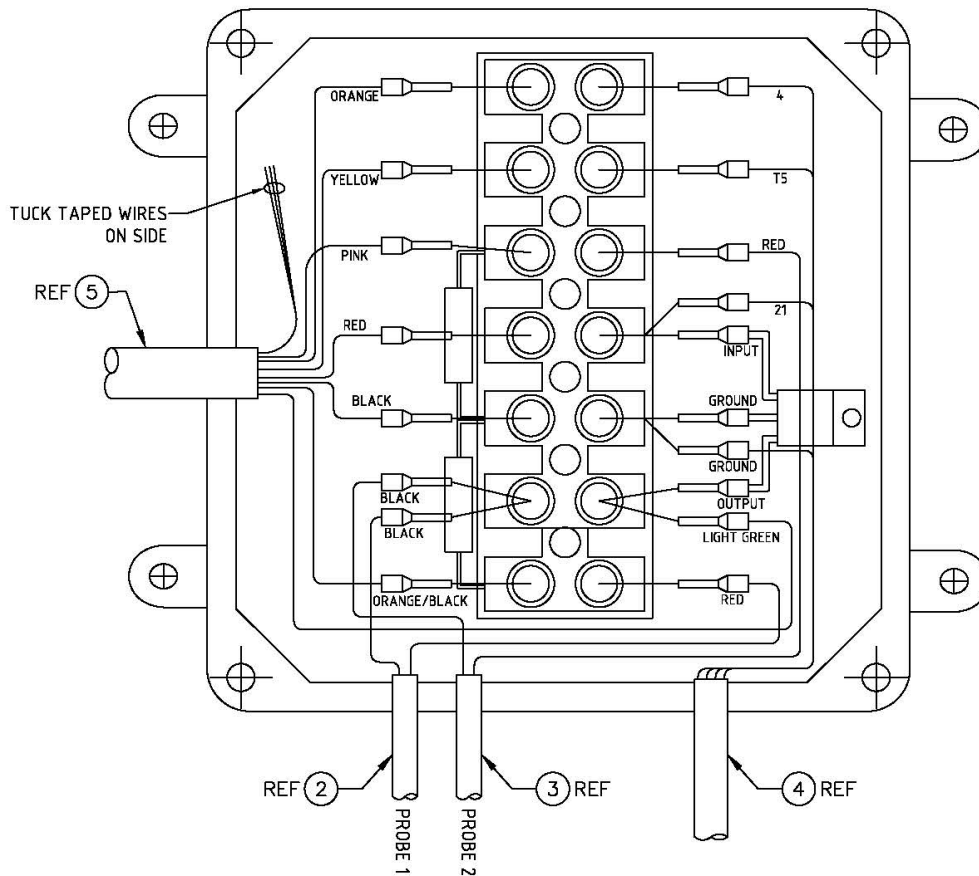
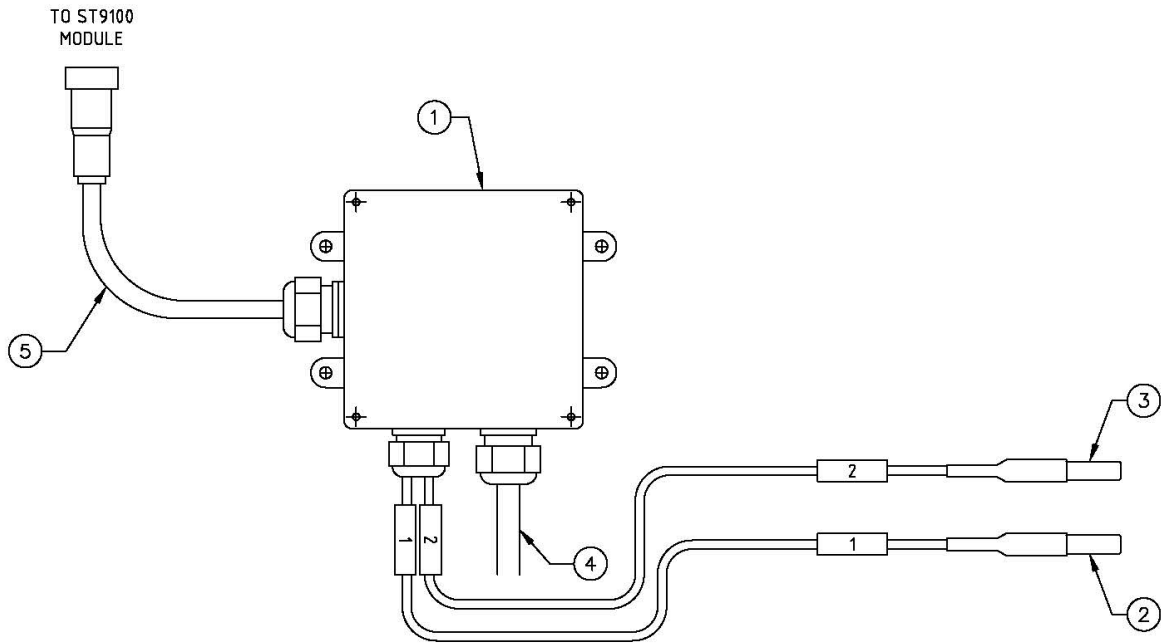

**SECTION 6.8**  
**ST9100 JUNCTION BOX**

**SECTION 6.8****ST9100 JUNCTION BOX**

<b>ITEM</b>	<b>PART NO.</b>	<b>DESCRIPTION</b>	<b>QTY.</b>
1	060-18792-01	BOX JUNCTION MODIFIED ST9100	1
2	360-18803-03	PROBE 1 RECORDER ST9100	1
3	360-18803-04	PROBE 2 RECORDER ST9100	1
4	360-18793-01	CABLE SIGNAL JUNCTION BOX END ST9100	1
5	360-18795-00	CABLE MODIFIED ST9100	1