

KLINGE

 THERMO KING

THAWING UNIT QTU-42 CE OPERATION, SERVICE AND PARTS MANUAL



MANUFACTURED BY KLINGE CORPORATION

Address: 4075 East Market Street York, PA 17402-5100 USA
Telephone: 717-840-4500 Telefax: 717-840-4501

www.klingecorp.com

TABLE OF CONTENTS

GENERAL SAFETY	6
SECTION 1. GENERAL DESCRIPTION.....	10
1.1 QTU-42 QUICK THAW UNIT	10
SECTION 2. REFRIGERATION SYSTEM	11
2.1 REFRIGERATION THEORY	11
2.2 REFRIGERANT R-404A or R-452A.....	11
2.3 UNIT PIPING DIAGRAM.....	12
SECTION 3. OPERATION	13
3.1 STARTING UNIT.....	13
3.2 UNIT OPERATING CYCLES.....	13
3.3 STOPPING UNIT	14
SECTION 4. ELECTRICAL AND ELECTRONIC FUNCTION	15
4.1 GENERAL INFORMATION	15
4.2 ELECTRIC BOX	15
4.3 DISPLAY BOX.....	17
4.4 ELECTRICAL DIAGRAM (MAIN POWER)	18
4.5 ELECTRICAL DIAGRAM (CONTROL POWER)	19
SECTION 5. CONTROLLER INSTRUCTIONS AND SEQUENCE.....	20
5.1 GENERAL INFORMATION	20
5.2 CONTROLLER.....	20
5.3 DISPLAY, CONTROLLER.....	22
5.4 KEYPAD, CONTROLLER	23
5.5 TEMPERATURE SENSOR.....	26
SECTION 6. MAINTENANCE AND SERVICE INSTRUCTION.....	27
6.1 SAFETY	27
6.2 CHECK REFRIGERANT CHARGE.....	28
6.3 PROCEDURE ADDING REFRIGERANT	28
6.4 NON-CONDENSABLE GASES	28
6.5 OPENING THE SYSTEM.....	29
6.6 TESTING FOR LEAKS.....	29
6.7 EVACUATING THE SYSTEM	29
SECTION 7. SERVICING COMPONENTS	30
7.1 COMPRESSOR.....	30
7.2 CONDENSER AND EVAPORATOR FANS MOTOR	31
7.3 CONDENSER AND EVAPORATOR FANS.....	31
7.4 FILTER-DRIER ASSEMBLY	31
7.5 HIGH-/LOW-PRESSURE SWITCH	32
7.6 THERMAL EXPANSION VALVE.....	32
7.7 CRANKCASE PRESSURE REGULATOR	32
7.8 LIQUID SOLENOID VALVE.....	32
7.9 NON-RETURN VALVE.....	33
7.10 LIQUID INJECTION VALVE COMPRESSOR	33
7.11 EMERGENCY SWITCH.....	33
7.12 OVERHEAT, SAFETY SWITCH	33
7.13 OVERHEAT SWITCH	34
SECTION 8. ALARM AND TROUBLE SHOOTING.....	35
8.1 GENERAL INFORMATION	35
8.2 ALARM/TROUBLE SHOOTING.....	35
8.3 UNIT INFORMATION.....	39
SECTION 9 SERVICE PARTS.....	40
9.1 HEAT-EVAPORATOR SECTION FRONT VIEW	41
9.2 HEAT-EVAPORATOR SECTION OPEN VIEW	43
9.3 COMPRESSOR-CONDENSER	45
9.4 ELECTRICAL BOX INSIDE	47
9.5 ELECTRICAL BOX LABELS AND CIRCUIT BREAKER HANDLE	49
9.6 DISPLAY BOX.....	51
9.7A MISCELLANEOUS PARTS	53

9.8 TEMPERATURE CONVERSION TABLES 57
9.9A STANDARD CEILING 58
9.9B PALLET WIDE 40FT CONTAINER CEILING..... 60
9.9C STANDARD 40FT CONTAINER CEILING 62

Service Request

Requests for Service should be directed to the Klinge Service Team. The below link should be used to place all requests for service and will afford the quickest response time.

<https://klingecorp.com/request-service/>

This form will help us determine model and age of the equipment, location, basic details about the issue, who to contact and how to best handle the issues with the equipment. A service ticket number will be provided in a response email once the form is received and processed. If the equipment is out of warranty, charges may apply for extensive technical support.

Additionally, our Service Department can be reached via email at technical@klingecorp.com.

Spare Parts Request

Requests for Spare Parts should be directed to our Parts Department via email at spares@klingecorp.com. Please have available at the time of the request the Serial Number of the equipment to ensure that the proper part is provided.

Use of this Manual

The use of this manual is intended for the safe operation of the equipment described. It is therefore reasoned that persons who have the occasion to use this manual have a knowledge of mechanical and electrical systems and components addressed by its' contents. However, efforts have been made to enable persons less familiar with these systems to use this manual.

The equipment may be installed in a number of configurations. Each may have optional items and differing external details provided by third parties. The specific electrical circuit and pipe diagram are posted on the unit as decals.

Most external and internal pipework parts are standard commercially available pipe fittings and not covered here. For external pipe fitting, replace like for like, taking care to replace stainless steel with stainless steel.

Suggestions as to improvement in content and format are welcome and should be addressed to engineering@klingecorp.com. Corrections and improvements will be included on dated revisions – the latest of which will be available upon request.

GENERAL SAFETY



Refer to Operation and Service Manual before operating and servicing equipment.



Use proper lockout/tagout procedures before servicing equipment.



Wear ear protection when working around the equipment for extended periods of time



Safety glasses should be worn at all times when operating or servicing the refrigeration unit.



Do not use this Equipment for any purpose not described in this Manual.



Do not operate this equipment without all guards and covers in place.



Do not operate this equipment from any power source that does not match the voltage rating stamped on the equipment. Refer to the Manufacturer's Identification Label for operational requirements.



Beware of high voltage (400-480 volt) in various parts of the unit, especially when CB1 is in the ON position. It is recommended that a thorough study of the wiring diagram be made to determine where high voltage may be encountered when electric power is fed to the unit.



Note: The electrical system will automatically restart the unit in case of power failures.



Supply power enters the bottom side of the main breaker.



Refrigerant is heavier than air. Therefore, it settles in the lowest places and will expel air (oxygen) from a small, confined space, resulting in dizziness or suffocation to an occupant.



Arc flash potential when equipment is operating.



Fans present possible hand injury when equipment is operating.

When installing, operating or servicing the equipment, follow all local regulatory standards.

All service and maintenance procedures should be performed in accordance with Section 608 of the Clean Air Act (CAA), prohibiting the venting of refrigerants into the atmosphere and providing for the use of refrigerant recycling and recovering equipment to be used whenever a system is opened.



Always wear approved goggles or eye shields when working with refrigerant to prevent eye injury if refrigerant is accidentally discharged into the face of the service engineer.

- When any work is to be done on the components of the refrigeration system, be sure that the unit cannot be started automatically or accidentally. If valves are closed and/or circuits interrupted during service procedures, the control switches should be suitably tagged with such notations.
- Do not exert excessive pressure when tightening flare nuts, as it may result in a rupture of the flare or stripped threads.
- Never, under any circumstances, apply heat to a refrigerant cylinder by using a naked flame. Should it be considered necessary to apply heat to a cylinder to create a refrigerant flow when recharging a system, place the cylinder in a container of hot or warm water to a point about 3/4 of the height of the cylinder.
 - Even this method requires that a pressure gauge is in use in the charging line to indicate the pressure in the cylinder at all times.
 - Never close the shut-off valve in the cylinder while the cylinder is being heated.
 - The use of a manifold gauge set will permit compliance with CAA regulations by having a gauge in the line and a shut-off valve on the manifold to stop the flow of refrigerant into the system and allow the gauge to read cylinder pressure.
 - Always replace refrigerant cylinder valve and connection caps after using the cylinder, and do not permit a cylinder to be dropped or hit severely by another object.

- Container related safety items:
 - Due to the height of the condenser unit on the external front wall of the container, always use safe and secure means to service the unit and allow a platform for tools.
 - Due to the configuration of the evaporator unit placed in the container, always use safe and secure means to service the unit including placement of tools and a refrigerant cylinder.
 - The internal space of the container should only be accessed by trained staff. It is suggested that specific company-based SOP's be established to monitor and govern this.
 - The roof of the container should only be accessed by trained staff. It is suggested that specific company-based SOP's be established to monitor and govern this. Also, it is highly recommended that proper fall protection is utilized.
 - Proper securing of internal cargo should be done to company established SOP's based on the type of cargo.

EQUIPMENT CLEANING

If it should become necessary to clean the exterior of the electrical panel of this equipment, do not use liquid cleaners, aerosols, abrasive pads, scouring powders or solvents, such as benzine or alcohol. Use a soft cloth lightly moistened with a mild detergent solution.

DISMANTLING AND DISPOSAL

1. Hydraulics/Lubricants – Must be recycled as required by local environmental law – do not dispose of by pouring down the drain.



2. Electronics – Must be recycled as required by local environmental law – do not dispose of by adding to the Municipal waste stream.



3. Metal/Other Parts of the System – Must be recycled as required by local environmental law.





4. Refrigerant – Must be reclaimed and recycled as required by local environmental law. Do not release refrigerant into atmosphere.

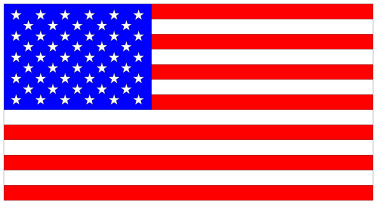

INFORMATION ON NOISE EMISSION

The Klinge Corporation, Model QTU-42 Sound Pressure and Sound Power Levels per EN ISO 11202 are as follows.

Model No: QTU-42	Serial No: As noted on Nameplate	Year of Construction: 2020	
		Operating	Idle
The equivalent continuous A-weighted sound pressure level in the operator's position		76 dB (A)	64 dB (A)
The background sound pressure levels, if the correction factor is required;		64 dB (A)	64 dB (A)
The peak C-weighted instantaneous sound pressure level in the operator's position		84 dB (C)	---
Sound power emitted where the equivalent continuous A-weighted SPL exceeds 80 dB (A).		---	---
Ambient Correction Factor K3A calculated according to EN ISO 11204 Appendix A.		3 dB (A)	
Equipment used for the measurements:		Center Model 325 S/N 110909369	
Calibration Method:		ANSI/ASA S1.4 Type 2, IEC 651 Type 2	
Date / Place of the most recent calibration.		22 MAY 2019 (Good for 1 year) Instrument Calibration and Technical Services 5312 Peters Road Suite E Roanoke, VA 24019 USA	
<p>The figures quoted are emission levels and are not necessarily safe working levels. While there is a correlation between the emission and exposure levels this cannot be used reliably to determine whether or not further precautions are required.</p> <p>Factors that influence the actual level of exposure of the workforce include characteristics of the work room, the other sources of noise, etc. such as the number of machines and other adjacent processes. Also, the permissible level of exposure can vary from country to country.</p> <p>This information, however, will enable the user of the machine to make a better evaluation of the hazard and risk.</p>			
	Klinge Corporation 4075 East Market Street York, PA 17402 USA		

SECTION 1. GENERAL DESCRIPTION

1.1 QTU-42 QUICK THAW UNIT

The QTU system (Quick Thaw Unit) controls the temperature in an isolated container (option, custom built chamber), containing meat or other products requiring a relatively fast thawing system.

The QTU system can keep the temperature constant (when storing meat) and it can increase the temperature (when thawing meat).

The QTU system consists of these 4 major components; evaporator/heater section, condenser section, electrical box and the microprocessor control display.

The microprocessor controller/data logger controls the temperature in the container. All settings and unit data can be set and checked from the microprocessor controller display.

The heating section is designed to fit into a container. (Option mounted in chamber.) The compressor/condenser section is mounted at the container front wall. (Option mounted outside building/on building roof.) The electrical box is also mounted on the container front wall. (Option can be mounted at a convenient location.)

The operating display/start panel is mounted on the rollup doorframe, alongside the door. (Option can be mounted at a convenient location.)

The container is delivered with one manual roll-up door.

The heating section consists of two ventilator fan motors with back curved fan, (right side ventilator fan motor has 2-speed operation), 42 kW heating elements and one evaporator coil. The compressor/condenser section is connected to the evaporator coil with copper pipe.

The unit frame structure, panels and supports are made of aluminum or stainless steel.

The microprocessor controller controls the container/cargo temperature. Once the temperature controller is set at the desired program, the unit will operate automatically to maintain the desired temperature.



Beware of high voltage (400-480 volt) in various parts of the unit. It is recommended that a thorough study of the wiring diagram be made to determine where high voltage may be encountered when electric power is fed to the unit.

The unit is designed to operate on 400/480VAC, 3 phase, 50/60 Hz, and ground. Control power is provided from transformer, to 28/24VAC.

Note: The electrical system will automatically restart the unit in case of power failures.

If the “power off” is less than 10 min. the unit will restart in the cycles, without interrupting the controller regulation system.

If the “power off” is more than 10 min. the unit will restart as a new loading/setting and all delay times will be reset.

If the unit is to be connected to an external alarm system, it is possible to use the “normal open or closed Alarm contact”, connected to terminal no. 16 - 17 or 16 - 18. (See Electrical diagram.)

Manual diagnostic, which is equipped in the microprocessor controller, allows a technician to manually operate individual components for diagnostics or repair work. This saves labor costs and makes reliable test inspections.

Air is discharged from the top of the heat section, through 2 louver plates over an adjustable ceiling. It then is pulled through the cargo and back through the ventilator fans. The ventilator fans run continuously, except on defrost cycle.

To ensure that the airflow is passed through the cargo, an adjustable ceiling cover is mounted.

Defrost is automatically activated by the microprocessor controller timer, by demand defrost, or it can be started manually from the display panel. Defrost completion is automatic when the temperature of the defrost sensor rises to a pre-set temperature, or by a timer if the pre-set temperature is not reached.

SECTION 2. REFRIGERATION SYSTEM

2.1 REFRIGERATION THEORY

Refer to the piping theory diagram figure below. This is a schematic piping diagram of a typical refrigeration circuit and will be referred to in the following explanation of refrigeration theory.

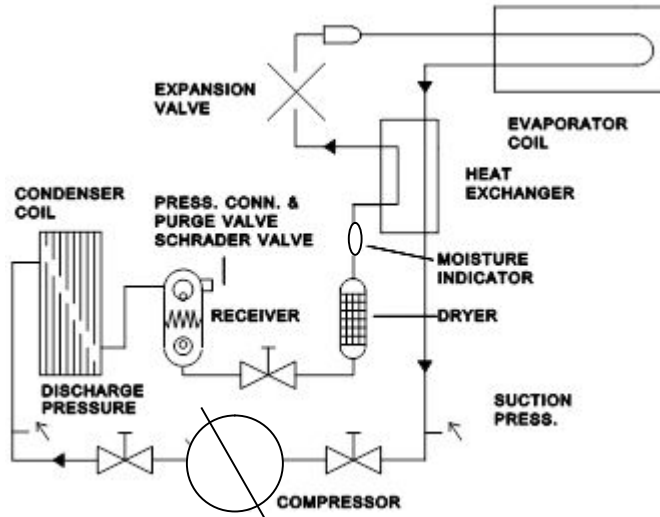

The method used to transfer heat from a place where it is not wanted to a place, where it is not objectionable, is the changing of a liquid to a vapor and changing of the vapor back to a liquid. Based on the schematic piping diagram, the following steps take place to produce cooling.

1. Starting at the compressor, refrigerant flows into the compressor as a low-temperature and low-pressure vapor. The compressor raises the pressure of the refrigerant by compressing the vapor making the refrigerant a high-temperature, high-pressure vapor.
2. The refrigerant then flows through the condenser coil. By using a fan to blow across the condenser coil heat is rejected and the vapor condenses from vapor form to liquid form, giving off heat in the process. When exiting the condenser coil the refrigerant will be high-temperature and high-pressure liquid. (If the system is equipped with a receiver, this is where extra liquid will be stored.)
3. After the condenser the refrigerant goes through the expansion valve. The inlet side of the valve is high-temperature and high-pressure liquid. Going through the valve is where the refrigerant experiences a pressure drop causing this side to be low-temperature and low-pressure liquid/vapor.
4. Finally, the refrigerant goes to the evaporator. The refrigerant draws heat from the evaporator which causes the refrigerant to vaporize. The evaporator draws heat from the region that is to be cooled. The vaporized refrigerant is now a low-temperature and low-pressure vapor which goes back to the compressor to restart the cycle.

2.2 REFRIGERANT R-404A or R-452A

Both R-404A and R-452A are CFC-free refrigerants and have ozone depletion potential zero. The compressor is charged with ester synthetic oil.

Moisture Indicator

A moisture indicator is installed in the liquid line immediately after the filter-drier, to indicate if there is moisture in the refrigerant charge.

The element, located in the center of the indicator, will change color on contact with moisture in the refrigerant passing over it. Refer to the color scale circling the element sight glass to gauge the amount of moisture in the system.

A colored leak-detecting agent, added to the refrigerant, will permanently discolor the indicator, and should therefore not be used. The moisture indicator will also become discolored if a compressor motor burn-out occurs and should be replaced after clean-out.

2.3 UNIT PIPING DIAGRAM

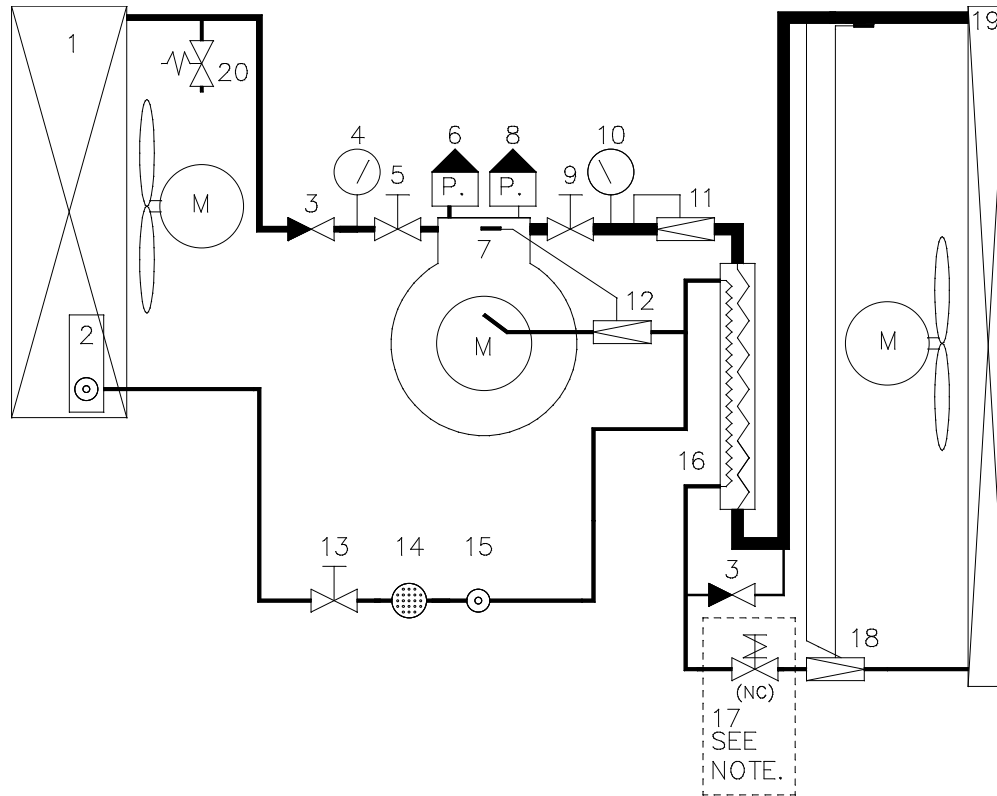

1. Condenser coil
2. Receiver
3. Non-return valve
4. Gauge high-pressure
5. Shut-off valve discharge line
6. Switch high-pressure
7. Compressor
8. Switch low-pressure
9. Shut-off valve suction line
10. Gauge low-pressure
11. Crankcase pressure regulator
12. Liquid injection valve
13. Liquid shut-off valve
14. Filter-drier
15. Sight glass
16. Heat Exchange
17. Solenoid valve Note: Not mounted, if the compressor/condenser section is mounted on the container front wall.
18. Expansion valve
19. Evaporator coil
20. Safety Relief valve

SECTION 3. OPERATION



Beware of high voltage (400-480 volt) in various parts of the unit. It is recommended that a thorough study of the wiring diagram be made to determine where high voltage may be encountered when electric power is fed to the unit.



**Fans present possible hand injury when equipment is operating.
DO NOT REMOVE CONDENSER GRILL OR OPEN EVAPORATOR DOOR BEFORE TURNING OFF POWER.**

3.1 STARTING UNIT

To understand the operation of the electrical and refrigeration system on the QTU unit, there are several things, which must be remembered:

- The main electrical operating power is 480V, 3-phase, 60Hz.
- The temperature in the container is controlled by the microprocessor controller/data logger.
- All settings and all unit data can be set, checked, or changed, from the microprocessor display/keyboard.
- The unit's refrigeration system is built as a simple standard refrigerant system, operating on R-404A or R-452A.
- There are two circuit breakers protecting the electric system. One protects the main line 480V 3 phase power, and one protecting the 28V control circuit.
- The high- / low-pressure switches are located on the compressor service valve ports and reset automatically.
- The compressor is equipped with overheat sensor, controlled by the microprocessor.

When the power is switched "ON", the unit will start up with timed delay functions. (See Section 5.) After 3 to 4 seconds the display will show the last entered program. If no key is operated, the unit will start after approximately 30 seconds in the last used program (as shown in the display).

If the setting is changed to a new program NO., the unit will start approximately 40 seconds after the last setting is entered. The unit will also start from display/keyboard.

Press and hold ESC and press ENTER.

In all programs used, the display will show program no.-unit status, and the actual temperature of all three-control sensors. (Surface - Center - and Return air temperature.)

If the program is used with "delay" starting time, the unit will operate the container according to the "delay temperature" set point, until the delay time runs out and then goes to Thawing.

(E.g. Load container Friday 4 PM, start Thawing Sunday 4PM, the delay must be set to 48 hours.

The unit will run the container at the storing temperature until Sunday 4PM, and then start the Thawing cycle.)

The setting in all programs, can be protected, by switching "Password protection" to "ON".

(See section 5.3-Config-Switch setting)

For self-diagnostics, the unit has a special "Run auto test" program in the controller. Start "Run auto test" (Start in "commands" in display) and the unit will run the Auto test for checking amperage on all motors/heaters and goes to normal operating after test.

(If a motor or heater failed, see event log.)

3.2 UNIT OPERATING CYCLES

THAWING CYCLE

The temperature sequence in the container is regulated so it does not exceed the set point of the three sensors as:

Max. Surface - Center - and Return air temperature.

The thaw program will operate the heating elements, by switching on heat steps until the correct balance is calculated. During the thaw sequence, the display will show the temperature of Surface - Center - and Return air temperature sensors. The PID routine is called every 10 seconds to ensure correct update of output. The result

will return with information on which heating elements should be heating. The thaw sequence is energized in the four heat contactors and splits the heat sequence in nine steps. The microprocessor will regulate the temperature, so it becomes equal to the sensor in control.

To clarify, the sequence is split into three stages:

During the first stage it regulates the temperature, so it becomes equal to "Max return air temperature".

The second stage starts when the product surface temperature reaches the set point "Surface temperature", from this stage it regulates the temperature, so it becomes equal to " Max. Surface temperature" setting.

The third stage---

(Programs 1 to 9. Best for big sized product.)

Starts when "Center temperature" reaches the set point, then the QTU regulates the temperature so the "return air temperature" is as close to the "Storage temperature" set point as possible. From that time on the storage algorithm is utilized.

The third stage---

(Programs 10 to 20. Best for small sized product.)

Starts when "Center temperature" reaches the set point, then the "Control Mode" in the QTU controller will maintain the "Center temperature" to the actual "Center temperature" setting. The controller will stay in this "Control Mode" for a minimum 20 hours after the Thawing cycle has been started, or if the "Return air temperature" reaches the "Surface temperature" set point, whichever comes first.

But at a maximum, the unit will switch over after 20 hours, to regulate the temperature so the "return air temperature" is as close to the "Storage temperature" set point as possible. From that time on the storage algorithm is utilized.

If there is a need to go in the container to check the product temperature, it is possible to switch OFF the unit, without interrupting the controller regulation system, if the check is done in less than 10 minutes. If the check takes more than 10 minutes, the unit will start up as a new load/setting and all delay times will be reset.

STORING CYCLE

When storing mode is requested, the compressor will operate, and the condenser fan will start to draw air over the condenser coil. The cargo space temperature will continue to pull down until 0.2°C below the set point (return air temperature).

At 0.2°C below set point, the compressor will stop and only the right-side ventilator fan will keep running at low speed. At 0.2°C above set point, the compressor will start again.

DEFROST CYCLE

The defrost cycle can be activated manually / or automatically by the controller. The defrost can be activated in 3 different ways:

Manual defrost Start using display.

(Start defrosts under "commands" in display).

Demand defrost Defrost will be activated, if the temperature difference between the return air sensor and the defrost sensor, is more than 10°C. in a period of 5 minutes.

NOTE: Demand defrosting criteria

If the Evaporator temperature is 18°C. below the Return air temperature, more than 300 seconds, the unit will start a defrost, but if it has only been 15 minutes. since the last defrost, alarm A18 will be set. (After alarm is set, the unit will only operate with timer defrosting.)

(A18. Evap. temperature too low, fail in air circulation.)

Demand defrost must be set to "ON" (set in "config, switch setting" in display, factory setting is "ON".)

Timer defrost Defrost interval can be set from 3 to 99 hour, (set under "config" in display) factory set is 12 Hour. (Compressor running hour)

The termination of the defrost is automatic, when the temperature of the defrost sensor (DF) rises to the preset limit; from -5° to 30°C. (set under "config" in display.), factory set is 18°C.

The controller will restart the unit, if the defrosting is not complete in the max. setting time. (Set under "config" in display), the time can be set from 15 to 99 min, factory set is 60 min.

3.3 STOPPING UNIT

Put unit [ON/OFF] switch in the [OFF] position.

SECTION 4. ELECTRICAL AND ELECTRONIC FUNCTION

4.1 GENERAL INFORMATION



Supply power enters the bottom side of the main breaker.

When high voltage is being fed to the unit, and circuit breaker (CB1, 80A) is in the ON position, the power will pass along L1, L2 and L3 line to the compressor motor relay (CM), condenser fan relay (CF), fan left-side relay (FL), fan right-side relay, high/low speed relay (FRH-FRL), heat element relay (H1-H2-H3-H4) and over circuit breaker (CB2.) to the transformer.



Beware of high voltage (400-480 volt) in various parts of the unit, especially when CB1 is in the ON position. It is recommended that a thorough study of the wiring diagram be made to determine where high voltage may be encountered when electric power is fed to the unit.



Note: The electrical system will automatically restart the unit in case of power failures.

When the unit ON/OFF switch is placed in the ON position, the POWER ON light is lit. Power will pass from the transformer, through the control circuit breaker (CB3 6A 28V), and to the controller logic (24V). All control box wires are identified with numbers.

Emergency switch (Inside container/chamber)

If the emergency switch (ES) is activated, the main switch will be switched OFF. (Unit stopped complete.) For restarting the unit, the emergency switch must be reset before the main switch can be activated.

4.2 ELECTRIC BOX

CIRCUIT BREAKER

- A. Circuit Breaker. (CB.1)
The 80A circuit breaker incorporates three breakers, one for each line. It is reset manually and protects the entire unit against overload.
The circuit breaker has an electrical activator, that will switch OFF the circuit breaker, in case the overheat switch OHR/OHL or the emergency switch (ES) trips.
- B. Circuit Breaker. (CB 2)
The 10A circuit breaker is reset manually and protects the 400V power to transformer, in case of possible overload.
- C. Circuit Breaker. (CB 3)
The 6A circuit breaker is reset manually and protects the 28V power from transformer, in case of possible overload.

RELAYS

- A. Compressor motor relay. (CM)
This is a 3 pole, 480V, direct-in-line contactor with 28V operating coil. It operates the compressor motor and is energized by the controller. The high-/low-pressure switch can interrupt the 28V.
- B. Condenser fan motor relay. (CF)

This is a 3 pole, 480V, direct-in-line contactor with 28V operating coil. It operates the condenser fan motor and is energized by the controller.

- C. Fan left side motor, relay. (FL)
This is a 3 pole, 480V, direct-in-line contactor with 28V operating coil. It operates fan motor left side and is energized by the controller. One auxiliary contact (normally open) signals the controller about relay condition.
- D. Fan right side motor. Low-speed relay. (FRL)
This is a 3 pole, 480V, direct-in-line contactor with 28V operating coil. It operates fan right side motor in low speed and is energized by the controller.
- E. Fan right side motor. High-speed relay. (FRH)
This is a 3 pole, 480V, direct-in-line contactor with 28V operating coil. It operates fan right side motor in high speed and is energized by the controller. On top of relay FRH, three auxiliary contacts are closed when the relay is energized, for connection of the star point, when the motor operates on high-speed. One auxiliary contact, on side of relay (normal open) gives signal to controller about relay condition.
- F. Heat element relay. (H1-H2-H3-H4)
This is 3 pole, 480V, direct-in-line contactor with 28V operating coil. It operates the heat element relays step 1-2-3-4 and is energized by the controller. The overheat switch OHR/OHL can interrupt the 28V.
- G. Solid state relay. (H1S)
This is a 2 pole, 480V, direct-in-line solid-state relay, operating on 28V. It operates/pulsing heat element step 1 and is energized by the controller.
- H. Safety relay. (SR)
The relay operates on 28V. It operates the power to the main control system, and also power to the circuit breaker (CB.1) activator, in case the overheat switch OHR/OHL or the emergency switch (ES) trips.

OVERLOAD RELAY

- A. Overload relay, fan motor right. Low speed. (OL1)
This is a 3 pole, 460V, direct-in-line overload relay, to protect the motor against missing a phase or overload etc. The overload relay is adjusted to 3A. The overload relay has manual reset.
- B. Overload relay, fan motor right. High speed. (OL2)
This is a 3 pole, 460V, direct-in-line overload relay, to protect the motor against missing a phase or overload etc. The overload relay is adjusted to 7A. The overload relay has manual reset.
- C. Overload relay, fan motor left. (OL3)
This is a 3 pole, 460V, direct-in-line overload relay, to protect the motor against missing phase or overload etc. The overload relay is adjusted to 7A. The overload relay has manual reset.
- D. Overload relay, heat step 1. (OL5)
This is a 3 pole, 460V, direct-in-line overload relay, to protect heat step 1 against overload etc. The overload relay is adjusted to 20A. The overload relay has manual reset.
- E. Overload relay, heat step 2. (OL6)
This is a 3 pole, 460V, direct-in-line overload relay, to protect heat step 2 against overload etc. The overload relay is adjusted to 16A. The overload relay has manual reset.
- F. Overload relay, heat step 3. (OL7)
This is a 3 pole, 460V, direct-in-line overload relay, to protect heat step 3 against overload etc. The overload relay is adjusted to 16A. The overload relay has manual reset.
- G. Overload relay, heat step 4. (OL8)
This is a 3 pole, 460V, direct-in-line overload relay, to protect heat step 4 against overload etc. The overload relay is adjusted to 16A. The overload relay has manual reset.
- H. Overload relay, compressor motor. (OL9)
This is a 3 pole, 460V, direct-in-line overload relay, to protect motor against missing a phase or overload etc. The overload relay is adjusted to 12.5A. The overload relay has manual reset.
- I. Overload relay, condenser fan motor. (OL10)
This is a 3 pole, 460V, direct-in-line overload relay, to protect motor against missing a phase or overload etc. The overload relay is adjusted to 1.12A. The overload relay has manual reset.

TRANSFORMER (TR)

The primary winding is connected to the line from circuit breaker CB 2. The secondary windings supply 28V for the control power, and 24V for the controller logic.

CURRENT TRANSFORMER (CT)

For showing the actual current of the unit in the display, the unit has one 3-phase current transformer installed. (See under "unit data" in display)

DELAY RELAY. (DER)

The delay relay operates the power to the electrical activator in the circuit breaker, according to the 0.5 sec. delay time setting. The delay gives time for the safety relay (SR) to be energized for normal condition, before the activator in the circuit breaker trips.

CONTROLLER. (MPC 3)

The microprocessor controller is based on the newest technology. It not only controls operation of the system, but also collects temperature to the data logger and data to the event logging.

- A. Controller, 16 relay output and 16 analog input, battery backup for setting of set point without starting the unit, and seven sensors for measuring of unit data information.
- B. Data logging, log interval can be set from 6 to 60 min., the data logger will contain data for approx. 30 days if the setting is 6 min., and approx. 300 days if the setting is 60 min.
Data log entries contain temperatures from all sensors. The oldest data will be overwritten by new data. Factory setting is 6 min (set under "config" in display)
- C. Event logging, log contains all information of the last 1500 events. (Main power ON/OFF --defrost start/end—set point change--alarm etc.
(See under data logger in display)
- D. The microprocessor controller has a software program that can be used for various units, to indicate that the controller shall be used for the QTU unit; the controller has a resistor code installed.
(10 Pole plug, pin 6-8).
The resistor code for the QTU controller is, 200 Ω .

BATTERY PACK (BAT)

A 6V rechargeable (Ni-MH) battery pack is installed in the system to supply power to the controller, if the unit is disconnected from power.
(The battery pack has a lifetime at approx. 2 years.)

EXTERNAL ALARM TIMER (AT)

If the unit is to be connected to an external alarm system, use the "normal open or closed alarm contact", connected to terminal no. 16 - 17 or 16 - 18. (See Electrical Diagram.)

4.3 DISPLAY BOX

ON/OFF SWITCH: The ON/OFF switch on the display box operates the unit start/stop.

LIGHTS: A. Power on. (Green.)

An L.E.D. indicates that power is on.

B. Alarm on. (Red.)

An L.E.D. indicates if there is any alarm coming from the controller. (See alarm information in display and troubleshooting section 8.)

DISPLAY: The display shows all information regarding temperature on all unit sensors, all data logged in data logger and all information for unit operating conditions.

KEYPADS: The four keypads are used for all unit operations, including setting of temperature, and scrolling in unit data information.

4.4 ELECTRICAL DIAGRAM (MAIN POWER)

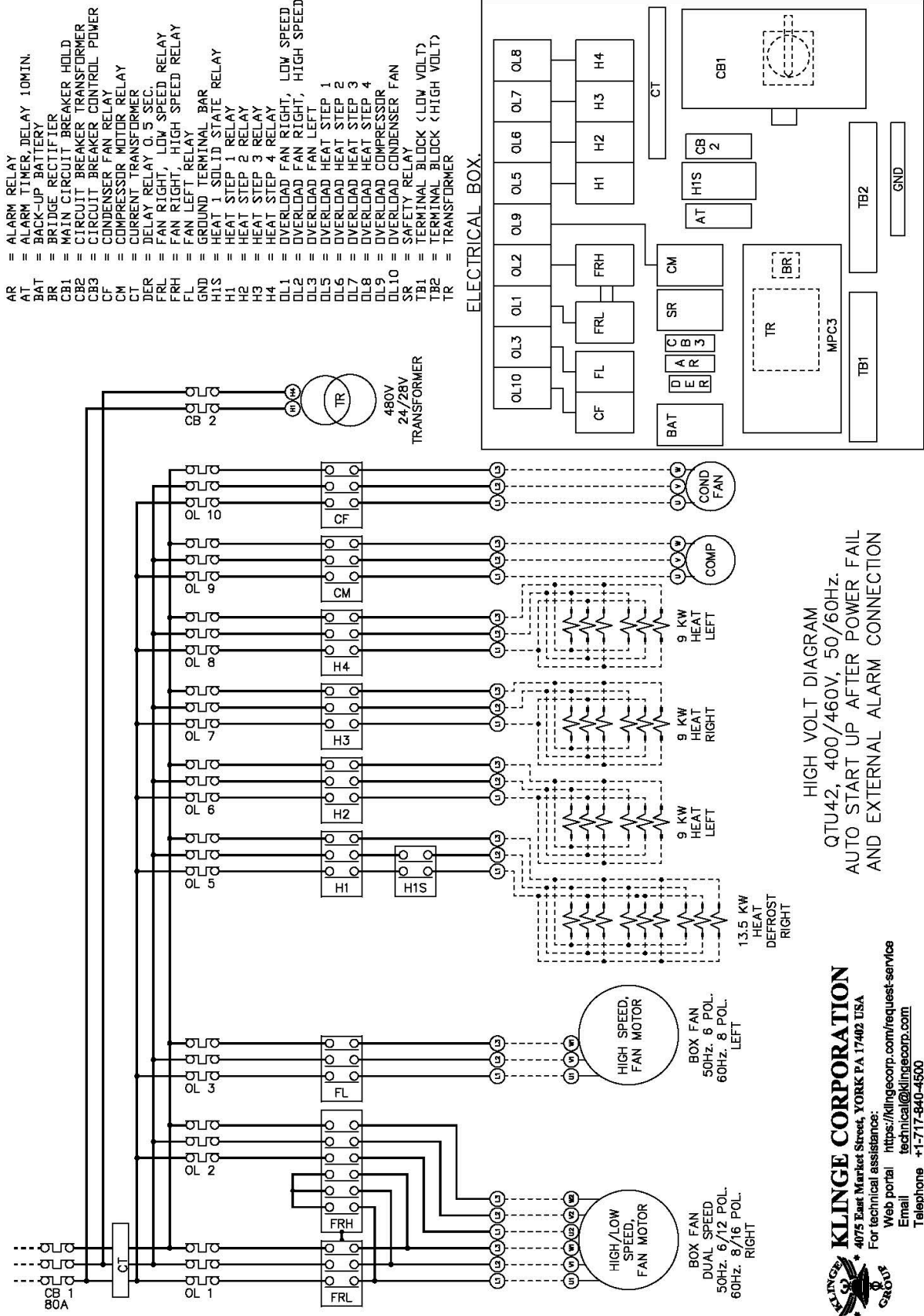

HIGH VOLT DIAGRAM
 QTU4-2, 400/460V, 50/60HZ.
 AUTO START UP AFTER POWER FAIL
 AND EXTERNAL ALARM CONNECTION

KLINGE CORPORATION
 4075 East Market Street, YORK PA 17402 USA
 For technical assistance:
 Web portal: <https://kingcorp.com/request-service>
 Email: technical@kingcorp.com
 Telephone: +1-717-840-4500
 For spare parts please email spares@kingcorp.com

K35-06614-00 REV: A

4.5 ELECTRICAL DIAGRAM (CONTROL POWER)

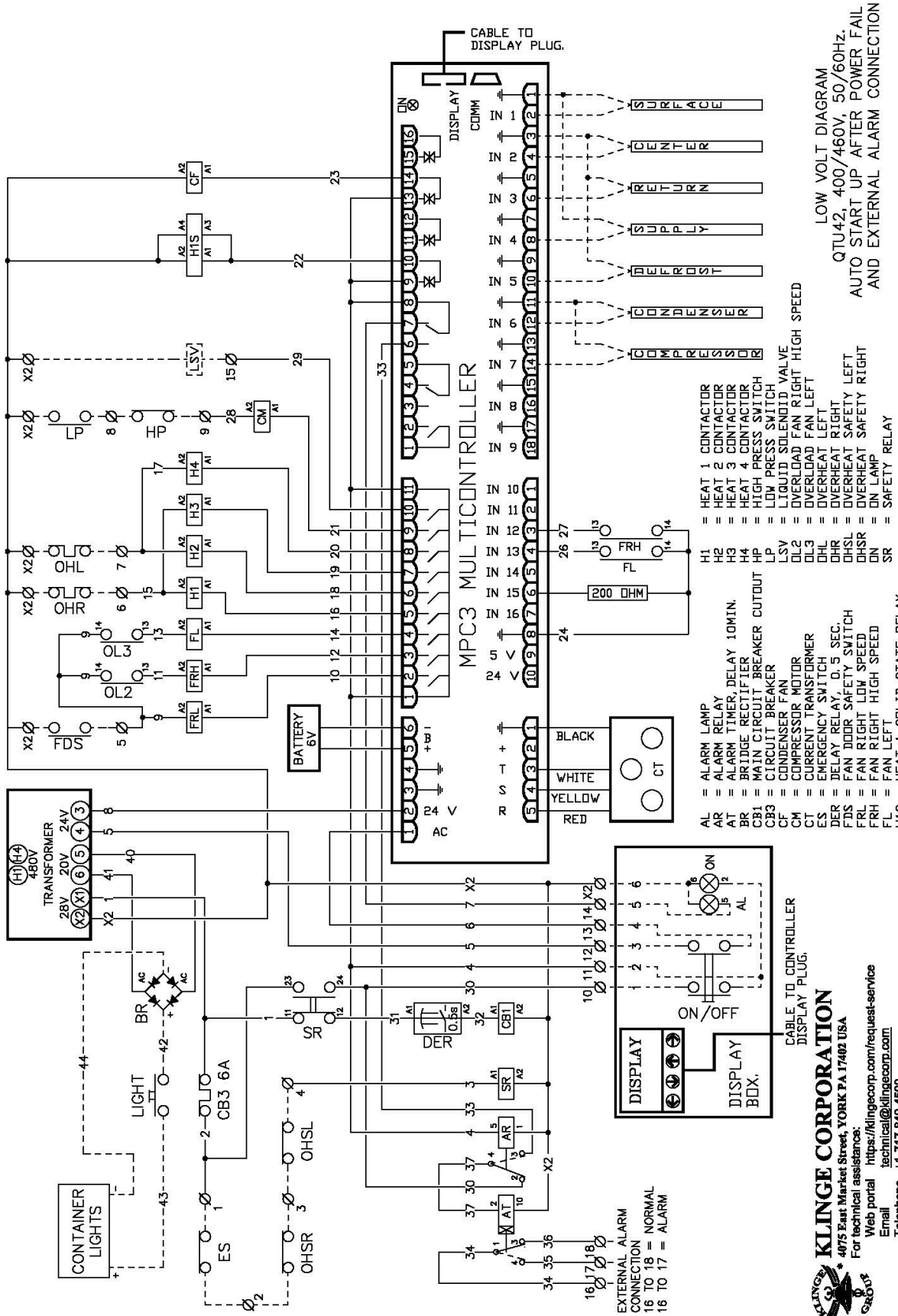

K35-06615-00 REV:F

KLINGE CORPORATION
 4075 East Market Street, YORK PA 17402 USA
 For technical assistance:
 Web portal <https://kingcorp.com/request-service>
 Email technical@kingcorp.com
 Telephone +1-717-840-4500
 For spare parts please email spares@kingcorp.com

SECTION 5. CONTROLLER INSTRUCTIONS AND SEQUENCE

5.1 GENERAL INFORMATION

The microprocessor controller system is based on the newest technology and consists of these parts:

- 1.The microprocessor controller.
- 2.The display/keypad.
- 3.Temperature sensors.

The controller is mounted in the electrical box, the display/keypad is mounted in the display panel box and all sensors are mounted in the container or on the system.

It is recommended that a voltmeter or an ohmmeter be used for trouble shooting the system. Be careful, because a short can cause damage to the electronic circuits. As control is related to resistance, an ohmmeter is required to check components.

The following will help you to understand the controller and the troubleshooting. PLEASE READ IT ALL CAREFULLY.

Several timer delays are incorporated in the controller and are not adjustable. Details of the time delays are explained later in this section under CONTROLLER STARTING SEQUENCE.

Accuracy is +/- 0.5°C max. Checking of temperature should be done with an instrument with equal or better accuracy.

5.2 CONTROLLER

This device contains all circuits necessary to select the functions required to maintain an accurate temperature. The selection is based on signals received from the sensors and the analog input.

When the unit ON/OFF switch is put in the "ON" position, the controller goes to mode "Start up" and the display will show, "BOOTING" - "SOFTWARE NO. /DATE and TIME" then "UNIT TYPE" for a few seconds before it shows "Program no./temperature of Surface, Center and Return air sensor."

The controller is always regulating the container temperature based on the three sensor temperatures, depending on what stage the program is in.

CONTROLLER REGULATION SEQUENCE

The controller regulation sequence:(Set point in °C.)

CONTROLLER SEQUENCE	
QTU 42 Thawing cycle	The controller will maintain the set point temperature, regulated to each sensor throughout each step. (PID reg.)
QTU 42 Storing cycle	The controller will stop cooling 0.5° below set point and start again 0.5° above set point.

Note. If the surface sensor is not placed correctly, (The surface temperature did not rise as normal, because the sensor is placed between two blocks of product, messaging, more likely the center temperature.) the regulation sequence will, if the surface sensor temperature is too low, start to regulate the return air temperature down, at - 11.8°C. per hour, until the return air temperature reaches 15°C.

The regulation sequence will maintain that temperature, until the surface or center sensor temperature, rises to the setting.

If the controller starts to operate after "Surface sensor too low" regulation, alarm A19 will be on. (Surface temp. too low)

CONTROLLER STARTING SEQUENCE

The starting sequence table below shows the two different start-up sequences:

Unit starting “ON/OFF” switch in ON position.

UNIT POWER ON	
<p>QTU 42 Thawing cycle (System start, app. 30 sec.)</p>	<p>Fan right side (RH) high speed on. <u>Next step: Delay 5 sec.</u> Fan left side (LH) on. <u>Next step: Delay 5 sec.</u> Heat step 1.on. <u>Next step: Delay 2 sec.</u> Heat step 2.on. <u>Next step: Delay 2 sec.</u> Heat step 3.on. <u>Next step: Delay 2 sec.</u> Heat step 4.on. <u>Next step: Delay 2 sec.</u></p>
<p>QTU 42 Storing cycle (System start, app. 30 sec.)</p>	<p>Fan right side (RL) low speed on. <u>Next step: Delay 5 sec.</u> Compressor on. <u>Next step: Delay 2 sec.</u> Condenser fan 1.on. <u>Next step: Delay 1 sec</u> (Fan will not start, if condenser temperature is below +20°C.)</p>

DEFROST CYCLE

Defrost is automatically activated by the microprocessor controller timer, by demand defrost or it can be started manually from the display panel. The completion is automatic when the temperature of the defrost sensor rises to a pre-set temperature.

For more detail see section 3.2.

5.3 DISPLAY, CONTROLLER

The LED display shows all information regarding all temperatures for system sensors, all data recorded by the data logger and all information for unit operating conditions.

DISPLAY MAIN MENU

DISPLAY, MAIN MENU ▼	The display will always show the following when unit is operating: "Program no.-Unit status (Thawing/Delay/Storing) - temperature of Surface- Center - and Return air sensor."		
Prg. X Mode "SF" "CT" "RT" Surface "SF" Center "CT" Return "RT" Supply "SU"	"Program no.-Unit mode (Thawing/Delay/Storing) - temperature of Surface- Center - and Return air sensor." SURFACE, shows the temperature for surface sensor, mounted on surface of the container cargo. CENTER, shows the temperature for center sensor, mounted in center of the container cargo. RETURN, shows the temperature for return air sensor, mounted in return air from container cargo. SUPPLY, shows the temperature for supply air sensor, mounted in supply air to container cargo.		
Config ▼	→		Unit type.
Datalogger ▼	→	Event Log. ▶ ↓	Container ID. QTUU0420010 Log Interval Set:6-60 Min.
Unit Data ▼	→	Temp. Log. ▶ ↓	DATE / TIME 01.03.23 16:00
Commands ▼	→	Input ▶	DEF.INTERVAL SET:3-99HOUR
Alarms (*) (*) Number of alarms. ▼	Shows all alarms	Manual defrost ↓ Manual test ↓ Run auto test	DEF.OFF.TEMP SET:5-30°C. DEF.MAX.TIME SET:15-99 MIN.
Mode: Storage. Delay. Thawing. Control. Defrost. ▼		Output ▶ ↓	Unit serial no. xxxxxxxxx
(Prg. X Mode)		Run hour ▶ ↓	Control setting ▶
		Time to Defrost (Hour) ↓	Switch setting ▶
			Temp. unit in °C "Off" Password Protection "ON/OFF" (To cancel password protection, write "FJ" in display.) Stop limit, timer for unloading container, set to 10 min. Demand defrost, set to "ON" Not used
			(Only for technical setting of different controller) A. Safety limit: Set to 30. =3hour running before surface sensor reaches set point. Set to 40 =4hour. B. Network no: Each controller can be coded with no. from 1 to 4, if there is more than one unit in

			Software ▶	Newest data			Not used.	the factory and if all units are linked to the same PC network. If only one unit, the network no. is 0.
--	--	--	------------	-------------	--	--	-----------	---

5.4 KEYPAD, CONTROLLER

The four keypads give access to all operations, setting of temperatures, and scrolling in unit data information.

Note:

The change in program and settings, must be done before the unit is started or starts automatically.

If no change is done in the settings, the unit will start on the last used program, automatically after 30 seconds or 40 seconds after operating one of the four keypads.

(If a program change is not completed in that time, the unit must be switched OFF and restarted.)

In the starting period the display shows:

Program No. xx and xx = time to start (count down from 30 seconds) product name and starting delay time.

The unit can also be started without starting delay: Press and hold (←) and Press (→).

If, Password Protection "ON" is activated, it is only possible to change program no. and the setting of storing temperature.

KEYPAD FUNCTION

<p>Program no. xx Change program. Up to 20 different programs. Program 0. only storing Program 1-20, are to be used for thawing, with different settings.</p> <p>Press and hold (←) use (↓) or (↑) to scroll in programs.</p>	<p>To change set point in program press (→) Use (↓) or (↑) for scrolling in the different settings: Temperature Surface sensor, can be set from -9° to 10°C. Temperature Center sensor, can be set from -10° to 9°C. Temperature Return air sensor, can be set from -10° to 40°C. Storing temperature, can be set from -30° to +15°C. Unit delay time, (time to thawing cycle start) can be set from 0 to 99 hours. Unit delay temperature, (temperature in container to thawing start) can be set from -25° to 0°C.</p> <p>Write name/type of product, up to 16 characters For setting/changing temperature/delay time (one at a time): Press (→) and "Arrows flash" use (↓) or (↑) for scrolling in value. Enter new setting press and hold (→) for 2 seconds.</p> <p>To write name/type of product: Press (→) ↓ "Arrows flash". BURGER Change the first character, 1. Use (↓) or (↑) to scroll 2. Use (→) to go to next character, and repeat no.1 Press and hold (→) for 2 seconds to enter name/type of product.</p>	<p>Display shows <u>save change</u> after each setting/change.</p>
<p>Display shows when program is started: PRG. xx THAWING "SF" "CT" "RT" Scroll, press (↓) or (↑)</p>	<p>When the program is started, the display will show: Program NO. and program status, actual temperature of: Surface sensor "SF" Center sensor "CT" and Return air sensor "RT".</p> <p>To inspect the set point in the program: Press (→), and use (↓) or (↑) to scroll in settings. (It is not possible to change setting when program is started.)</p>	
<p>Unit sensor temperature. Scroll, press (↓) or (↑)</p>	<p>Display shows temperature of: "Surface, Center, Return air and Supply air sensor."</p>	
<p>Config. >> Press (→) to enter Scroll, press (↓) or (↑)</p>	<p>Unit type. QTU 42. Scroll, press (↓) Esc. press (←)</p>	

Esc. press (←)	Container ID. >> "NFRU0010170" Press (→) to change. Scroll, press (↓) or (↑) Esc. press (←)	↓----- "Arrow flash" NFRU0010170 Change the first character, 1. Use (↓) or (↑) to scroll 2. Use (→) to go to next character, and repeat no.1 Press and hold (→) for 2 seconds to enter new ID. no.	Display shows, save change.
	Log interval. >> Press (→) to change. Scroll, press (↓) or (↑) Esc. press (←)	"Arrows flash". Use (↓) or (↑) for changing log interval. Press and hold (→) for 2 seconds to enter new interval.	Display shows, save change.
	Date and time. >> Press (→) to change. Scroll, press (↓) or (↑) Esc. press (←)	Year 01-month 01-date 20. Time 12-min.30 ↑↓ (Arrows flash) Change the first value, 1. use (↓) or (↑) to change. 2. use (→) to go to next item, and repeat 1 Press and hold (→) for 2 seconds to enter new date/time.	Display shows, save change.
Config. >> Press (→) to enter Scroll, press (↓) or (↑) Esc. press (←)	Defrost interval. >> Press (→) to change. Scroll, press (↓) or (↑) Esc. press (←)	"Arrows flash". (factory set to 12 hours.) Use (↓) or (↑) for changing defrost interval. Press and hold (→) for 2 seconds to enter new interval.	Display shows, save change.
	Defrost termination temperature. >> Press (→) to change. Scroll, press (↓) or (↑) Esc. press (←)	"Arrows flash". (factory set to 18°C.) Use (↓) or (↑) for changing termination temperature. Press and hold (→) for 2 seconds to enter new temperature.	Display shows, save change.
	Defrost max. time. >> Press (→) to change. Scroll, press (↓) or (↑) Esc. press (←)	"Arrows flash". (factory set to 60 min.) Use (↓) or (↑) for changing max. defrost time. Press and hold (→) for 2 seconds to enter new setting.	Display shows, save change.
	Unit series no. >> "xxxx xx xxxx" Press (→) to change. Scroll, press (↓) or (↑) Esc. press (←)	↓----- "Arrow flash" xxxx xx xxxx Change the first character 1. Use (↓) or (↑) to scroll 2. Use (→) to go to next character, and repeat no.1 Press and hold (→) for 2 seconds to enter new no.	Display shows, save change.
	Control setting. >> Press (→) to enter Scroll, press (↓) or (↑) Esc. press (←)	(Only for technical setting of different controller) Safety limit: Set to 30 = 3 hour running before surface sensor reaches set point. Network No: Each controller can be coded with a no. from 1 to 4, if there is more than one unit in the factory and if all units are linked to the same PC network. If only one unit, the network no. is 0.	
	Switch setting. >> Press (→) to change. Scroll, press (↑) Esc. press (←)	Unit temperature in °F or °C ON = °F OFF = °C Password protec. ON = Password active OFF = Password inactive (To cancel password protection, write "FJ" in display, same procedure as unit series no.) Cargo sensor Alarm. Not used on QTU unit Remove message, must be set to <u>OFF</u> . Stop limit, timer for unloading container, set to <u>10 min.</u> Use (↓) or (↑) to scroll in menu of settings. Use (↓) or (↑) to change ON/OFF Press and hold (→) for 2 seconds to enter new setting.	Display shows, save change.
Datalogger >> Press (→) to enter. Scroll, press (↓) or (↑) Esc. press (←)	Temperature log >> Press (→) for information Scroll, press (↓) Esc. press (←)	Use (↓) or (↑) to scroll in time, and (←) or (→) to scroll in temperature. Esc. press (←)	
	Event log >> Press (→) for information Scroll, press (↑) Esc. press (←)	Use (↓) or (↑) to scroll in time, and event log. Press (→) for more information. Press (←) for esc.	Event log Information Esc. press (←)

Unit data >> Press (→) to enter. Scroll, press (↓) or (↑) Esc. press (←)	Input >> Press (→) to enter. Scroll, press (↓) Esc. press (←)	All unit controller data input Use (↑) or (↓) to scroll in menu. Esc. press (←)	
	Output >> Press (→) to enter. Scroll, press (↓) or (↑) Esc. press (←)	All unit controller data output Use (↑) or (↓) to scroll in menu. Esc. press (←)	
	Run hour >> Press (→) to enter. Scroll, press (↓) or (↑) Esc. press (←)	All unit Hours Use (↑) or (↓) to scroll in menu. Esc. press (←)	
	Time to defrost >> Scroll, press (↓) or (↑) Esc. press (←)	Display shows time to next defrost.	
	Software ID >> Scroll, press (↑) Esc. press (←)	Display shows software ID.	
Commands >> Press (→) to enter. Scroll, press (↓) or (↑) Esc. press (←)	Manual defrost >> Scroll, press (↓) Esc. press (←)	Display shows defrost.	
	Manual test >> Press (→) to enter. Scroll, press (↓) or (↑) Esc. press (←)	Relay, energized = 1. de-energized = 0 1 0 0 0 0 0 0 0 0 0 0 0 0 0 0 0 Name of ↑ 599-sec.max.operating time. Energized relay Use (↓) or (↑) to scroll between relays (1/0) Press (→) for ON/OFF function. After energizing the relay, wait 3 seconds and the display switches over and shows the amperage on all 3 phases. For energized heat step 1-3, Fan RH must be activated. For energized heat step 2-4, Fan LH must be activated. Esc. press (←)	
	Run auto test >> Press (→) to enter. Scroll, press (↓) or (↑) Esc. press (←)	The display shows the actual parts which are tested, and the load current of that part. (Motor-compressor e.g.) Esc. press (←) (The test result is also shown in the Event log.)	
Alarm >> Press (→) to enter. Scroll, press (↓) or (↑) Esc. press (←)	Display shows current alarm, or no alarm. Press (→) to cancel alarm.		

5.5 TEMPERATURE SENSOR

The temperature sensor is an NTC thermistor element, placed in a sealed metal tube, which is connected to a two-conductor cable. The temperature signal from the sensor is relayed to the controller through this cable. The accuracy of this will not change, except for an internal malfunction of the sensor itself. If one of the sensors has an open/short circuit, the current alarm will be showing in display as “----sensor out of range”.

Use an ohmmeter only to check. Ohm “ Ω ” readings should agree with the following chart:

(Use the Temperature Conversion Chart in Section 9.8 for values in °F.)

Sensor NTC									
°C	Ω	°C	Ω	°C	Ω	°C	Ω	°C	Ω
120	109.84	88	251.41	56	662.22	24	2073.18	-8	8131.44
119	112.51	87	258.55	55	684.36	23	2155.36	-9	8524.23
118	115.26	86	265.92	54	707.36	22	2241.30	-10	8938.65
117	118.09	85	273.54	53	731.27	21	2331.21	-11	9376.03
116	121.00	84	281.42	52	756.11	20	2425.28	-12	9837.80
115	124.00	83	289.57	51	781.93	19	2523.74	-13	10325.47
114	127.09	82	297.99	50	808.77	18	2626.82	-14	10840.65
113	130.27	81	306.70	49	836.69	17	2734.74	-15	11385.08
112	133.55	80	315.72	48	865.73	16	2847.79	-16	11960.60
111	136.92	79	325.04	47	895.93	15	2966.22	-17	12569.21
110	140.39	78	334.69	46	927.36	14	3090.32	-18	13213.00
109	143.93	77	344.68	45	960.07	13	3220.41	-19	13849.25
108	147.66	76	355.01	44	994.11	12	3356.80	-20	14615.38
107	151.47	75	365.71	43	1029.55	11	3499.83	-21	15378.98
106	155.38	74	376.79	42	1066.46	10	3649.88	-22	16187.84
105	159.42	73	388.26	41	1104.90	9	3807.32	-23	17044.94
104	163.59	72	400.14	40	1144.94	8	3972.57	-24	17953.48
103	167.88	71	412.45	39	1186.66	7	4146.05	-25	18916.88
102	172.31	70	425.21	38	1230.14	6	4328.24	-26	19938.83
101	176.87	69	438.42	37	1275.46	5	4519.61	-27	21023.28
100	181.58	68	452.12	36	1322.70	4	4720.69	-28	22174.47
99	186.44	67	466.31	35	1371.97	3	4932.03	-29	23396.95
98	191.45	66	481.03	34	1423.36	2	5154.22	-30	24695.63
97	196.62	65	496.29	33	1476.96	1	5387.87	-31	26075.77
96	201.96	64	512.12	32	1532.90	+/-0	5633.65	-32	27543.04
95	207.47	63	528.54	31	1591.28	-1	5892.27	-33	29103.54
94	213.16	62	545.57	30	1652.21	-2	6164.47	-34	30763.82
93	219.03	61	563.24	29	1715.84	-3	6451.05	-35	32530.96
92	225.10	60	581.58	28	1782.24	-4	6752.87	-36	34412.57
91	231.36	59	600.62	27	1851.70	-5	7070.82	-37	36416.87
90	237.83	58	620.39	26	1924.22	-6	7405.87	-38	38552.70
89	244.51	57	640.91	25	2000.00	-7	7759.04	-39	40829.62

SECTION 6. MAINTENANCE AND SERVICE INSTRUCTION

This section provides procedures for establishing preventive maintenance and systematic servicing schedules, which are the keys to successful operation.

6.1 SAFETY



Always wear approved goggles or eye shields when working with refrigerant to prevent eye injury if refrigerant is accidentally discharged into the face of the service engineer.



Refrigerant is heavier than air. Therefore, it settles in the lowest places and will expel air (oxygen) from a small, confined space, resulting in dizziness or suffocation to an occupant.

- When any work is to be done on the components of the refrigeration system, always make sure that the equipment cannot be started automatically or accidentally. If valves are closed and/or circuits interrupted during service procedures, the control switches should be suitably tagged with such notations.
- Use proper tools when servicing the equipment.
- Do not exert excessive pressure when tightening flare nuts, as it may result in a rupture of the flare or stripped threads.
- Never under any circumstances apply heat to a refrigerant cylinder by using a naked flame. Should it be considered necessary to apply heat to a cylinder to create a refrigerant flow when recharging a system, place the cylinder in a container of hot or warm water to a point about 3/4 of the height of the cylinder.
 - Even this method requires that a pressure gauge is in use in the charging line to indicate the pressure in the cylinder at all times.
 - Also, never close the shut-off valve on the cylinder while the cylinder is being heated.
 - The use of a manifold gauge set will permit compliance with having a gauge in the line and a shut-off valve on the manifold to stop the flow of refrigerant into the system and allow the gauge to read cylinder pressure.
- Always replace refrigerant cylinder valve and connection caps after using the cylinder, and do not permit a cylinder to be dropped or hit severely by another object.
- Due to the height at which the refrigeration unit is placed in the container, always use safe and secure means to service the unit and to allow a platform for tools and a refrigerant cylinder.
- Never loosen a refrigerant line rapidly if there is positive pressure in the line:
 - Because liquid refrigerant may give you a severe cold burn, or other injury.
 - Because gas refrigerant may also cause oil to discharge, leaving the compressor short of oil, and creating an oily mess over the unit and service engineer.

6.2 CHECK REFRIGERANT CHARGE

Checking with the unit operating.

The receiver sight glasses are equipped with a ball, which floats when the liquid level is in the sight glass or above. It should be noted and remembered that the only requirement of liquid level is that a seal be maintained at the outlet of the receiver. At low refrigerant flow rate, the liquid refrigerant may not accumulate in the receiver to a point where a liquid level will show on the sight glass. Many times, the liquid will hang up in the condenser; therefore, caution should be taken before adding refrigerant. Air in the receiver may also prevent the level from coming up into the sight glass. If the ball is not floating, it is recommended that the pressures be checked according to the suction and the discharge pressures noted on the graphs provided before determining that the charge is low.



It is just as possible to do harm to the system by overcharging, as it is to run it undercharged.

It is important to have the correct amount of refrigerant in the system. If there is too little, the expansion valve will pass vapor and reduce the capacity of the evaporator. Too much refrigerant will result in higher head pressures and oil dilution.

An air-cooled system will operate at many different ambient temperatures and the performance of the system will vary accordingly. Therefore, before adding any refrigerant (or making any other adjustments), it should be taken into consideration whether the unit is running with a low-temperature load or a high-temperature load, running in a cold ambient or a hot ambient load and most important, whether the suction and the discharge pressures are in line for existing conditions.

Unit capacity will be greatly reduced when high-temperature ambient is experienced; therefore, a careful check should be made of unit performance before making any adjustments or adding refrigerant to the system.

Before adding refrigerant, always determine the reason for the low charge and remedy the cause. Leak test thoroughly with an electronic leak detector and check also for traces of oil.

For charge capacity of the system, see Section 8.3.

6.3 PROCEDURE ADDING REFRIGERANT



Before adding refrigerant, it is important to purge the air from the transfer tubes of the manifold gauge set.

- a. Remove the compressor suction service valve cap and backseat the valve. This closes the charging port. Remove the cap from port and loosely attach the suction gauge line of a manifold set. Connect the charging line to the refrigerant cylinder and tighten the connection.
- b. Crack open the cylinder valve and the manifold suction gauge valve and allow the entire line to purge the air, then tighten the connections at the compressor.
- c. With the system still operating and the suction pressure at 3 bar or below, and the cylinder pressure at 5 bar (dependent upon room temperature), open the refrigerant cylinder liquid valve completely and the manifold suction valve and crack open the compressor suction service valve, 1 to 2 turns.
- d. Allow refrigerant into the system and observe the receiver sight glass (20-30 second bursts with a 5-minute interval).
- e. If the pressure in the refrigerant cylinder equalizes the suction pressure of the system, charging will cease until the cylinder pressure is raised, by heating it up. To speed this, a container of hot water or an electric blanket (made for this purpose) can safely be used; if care is taken a metal-shielded heat lamp can be used as well.
- f. When it is determined that the system has an adequate refrigerant charge, close the refrigerant cylinder valve (if not already closed) and the manifold suction gauge valve, and backseat the suction service valve, in that order. Remove the manifold lines and replace the caps securely.

6.4 NON-CONDENSABLE GASES

Air and non-condensable gases in any system gather in the receiver above the liquid. These can be removed during operation by purging through the valve provided for this purpose at the receiver. To purge, depress the Schrader type valve core for a few seconds. Note any significant difference from the initial pressure when the valve is again closed.

Repeat the operation until the pressure is approximately equal to the refrigerant vapor pressure corresponding to the temperature of the receiver.

6.5 OPENING THE SYSTEM

Whenever it is necessary to open a charged or functioning system to service or make repairs, the refrigerant must be discharged from that part of the refrigerant circuit to a slightly positive pressure before the system is opened. If the final pressure is reduced to less than atmospheric, sufficient refrigerant should be bled into the evacuated part of the system to raise the pressure to approx. 0.1 bar. Connections may then be broken, and the necessary repairs made. One connection should be made first so that air in that part may be swept out through the free end by purging with refrigerant gas bled from the charge in the system. The other connection or connections should be promptly made. If, after breaking the connections, more than a few minutes must elapse, the free ends of the system should be capped.

Extreme care must always be taken to prevent the entrance of moisture and dirt into the system.

It is essential when brazed joints are to be un-brazed, the residual pressure in the line be vented to the atmosphere prior to the application of heat.

The use of "EASY-FLOW" silver solder and flux, or equivalent, is recommended in the refrigerant system piping. Do not use soft solder.

Prior to disturbing any connections, the type of solder originally used should first be verified - then continue. By taking this precaution, contamination of the joint will be avoided.

6.6 TESTING FOR LEAKS

The preferred method for finding leaks is by use of an electronic leak detector. There are several different makes available and they all use the same method of detecting a leak through an exploring tube, which will detect from large to extremely small leaks depending on the setting used on the detector.

Leak testing with soap suds will reveal only the large leaks and is therefore ineffective in determining the tightness of a system.

To provide the best possible condition for leak checking the system, it is recommended that the system pressure of the refrigerant must be increased, by adding dry nitrogen to create a pressure suitable for checking.

6.7 EVACUATING THE SYSTEM



Do not use the compressor as a vacuum pump or as an air compressor.

The compressor is not designed to handle air and will not pull down to as low a vacuum as a pump designed for that purpose. Similarly, if used to compress air, serious overheating and consequent damage may be the result.

Connect a pump capable of drawing a vacuum of 0.15 mm HG or greater to that part of the system which has been opened. Continue until all air and moisture have been removed.

Too much emphasis cannot be placed on the importance of keeping the system free of moisture. Slight amounts of water in the system will inevitably lead to trouble in the following forms:

- a. Corrosion of the steel parts.
- b. Copper plating of the shaft and the bearing.
- c. Slugging or gumming of the oil.
- d. Plugging of the strainers and the filter-driers.
- e. Freezing and plugging of the expansion valve.

SECTION 7. SERVICING COMPONENTS

7.1 COMPRESSOR

COMPRESSOR MOTOR PROTECTION

The scroll compressor motors are equipped with an internal overload / overheat device. This device will break the star-point and stop the compressor, if any problem causes the motor to overheat. When the motor cools sufficiently the overload will reset automatically.



Ensure proper rotation when the compressor is started.

The scroll compressor will only compress in one rotational direction. Reverse rotation results in a sound level above what is normal in correct rotation, and there will be no reaction in suction – and discharge pressure.

COMPRESSOR LUBRICATION

In order to check the oil level in the compressor, a sight glass is provided in the front of the shell, allowing the oil inside to be visible at all times.

Since the oil level will vary with operating conditions, it should be checked only after the compressor has been running long enough for the crankcase to warm up to operating conditions. The level in the sight glass shall be visible when the compressor is running. If the level is low, oil should be added to max. 1/2 level sight glass.

ADDING OIL

As there is no means of pouring oil into the compressor, as there is on hermetic compressors, oil must be sucked into the crankcase by way of the suction service valve, compressor must be separated from the system. Front seat the suction valve on the compressor and run the compressor to a pressure of 0 bar. Stop the compressor and front seat the discharge valve on the compressor.

Although this procedure is relatively simple, some preparations and care must be taken as follows:

- a. Carefully disconnect the cap from the 1/4" service adapters on the suction and discharge valve, and slowly release pressure from the compressor.
- b. Connect the vacuum pump to the 1/4" service adapters on the discharge valve.
- c. Connect a charging hose to the 1/4" service adapters on the suction valve.
- d. Now place the end of the charging hose into the can of oil and start the vacuum pump. Continue to take the pressure to vacuum, and pull the oil into the crankcase, and monitor the oil level in the compressor sight glass, stop the vacuum pump.
- e. As soon as enough oil has been transferred to the compressor, disconnect the charging hose and replace the 1/4" cap on the suction service valve adapter. Start the vacuum pump and run vacuum to a pressure of 0.15 mm HG. or greater in the compressor, backseat the compressor service valves and start the unit.
- f. Allow the unit to run 30 minutes. Re-check the oil level in the compressor sight glass, immediately after the compressor has been shut off.

Note: Always keep commercial oil stored in sealed containers. Oil exposed to the atmosphere will absorb moisture, which can cause trouble when introduced into the system. Use only the grades of oil which are suitable and recommended for compressor lubrication and have been specially processed to have the necessary low moisture content.

The following oils are suitable:

Mobil Ester oil EAL 22CC

or ICI Emkarate RL32CF

(are miscible)

Norfrig P/N 6090.7026 (4 l. can)

COMPRESSOR MOTOR BURN-OUT

When a hermetic motor burn-out occurs, the stator winding insulation decomposes forming carbon, water, and acid. To prevent contamination of the refrigerant system and repeat the motor failures, steps must be taken to ensure that the refrigerant circuit is kept clean from contamination.

Important: Damage to a compressor caused by failure to clean the system properly after burn-out constitutes abuse and is not covered by the terms of the warranty.

Note: After it has been observed that a hermetic motor has failed either by observing an obvious electrical fault or by a strong burned odor to the refrigerant gas released at the discharge valve port, the following procedure must be followed to clean the system and thus prevent failure of a replacement compressor.



Acids are formed during a motor burn-out. Use rubber gloves, and eye protection when working on the system or handling contaminated parts.

Moisture is a normal product of decomposition and is very harmful in a refrigeration system. However, it is one of the easiest products to remove. Acids, both hydrochloric and hydrofluoric, are generated. Both are highly corrosive and hydrofluoric is the only acid that will attack glass.

Note: The etching of various sight glasses around the system will give an indication of the extent of contamination. The acid, most of which concentrates in the compressor oil, must be removed to prevent failure of the replacement compressor.

CLEAN OUT PROCEDURE

- a. To recover the refrigeration from the refrigeration system, use a recover or reclaim system, so that the refrigerant can be reused.
- b. Replace the oil in the compressor.
- c. Replace the filter-drier (replace the moisture indicator, if necessary).
- d. Evacuate the system.
Note: It is vital to use a high stage vacuum pump to eliminate any moisture in the refrigerant system. The most effective method is to use a two-stage vacuum pump. A high-stage vacuum pump will remove all the moisture in the refrigerant system because it lowers the pressure in the system to a level at which the water will boil.
- e. Charge the system with the refrigerant.
- f. Run the system for approximately 6 hours.
- g. Make an acid test.
If the oil sample indicates acid, pump down the system and close the compressor service valve, drain the compressor of the oil and refill with new oil. Replace the filter-drier.
- h. Run the refrigeration unit for an additional 6 hours, then perform a new acid test. Repeat the above procedure until the system is free of acid.

7.2 CONDENSER AND EVAPORATOR FANS MOTOR

These totally enclosed motors are equipped with shielded ball bearings, which do not require lubrication under normal service conditions.

7.3 CONDENSER AND EVAPORATOR FANS

If a motor fan must be removed from the motor shaft, for any reason, be sure that the fan is relocated, to the same position.

7.4 FILTER-DRIER ASSEMBLY

A replaceable filter-drier is installed in the liquid line. It removes moisture and dust from the refrigerant while it is circulated.

TO REPLACE THE SYSTEM FILTER-DRIER

If the moisture indicator shows a color identifying moisture in the system, based on the indicator's color code, or if the outlet side of the filter-drier feels cooler than the inlet side, the filter-drier should be changed.

1. Close the liquid line shut-off valve, and pump down the system until the suction pressure stabilizes at 0 bar. Remove all power to unit, then front seat the suction service valve on the compressor.
2. Un-solder the filter-drier. Remove filter-drier from clamp.
3. Remove caps from new filter-drier and install immediately. Orient correctly by noting the flow arrow.
4. Connect the liquid line to the filter-drier, and solder in place.

If replacement of the filter-drier is accomplished fast enough, there will be no need to purge air out of the lines.

5. Tighten clamp on new filter-drier cartridge securely. Open shut-off valve and suction service valve, and the unit is ready to run again.

7.5 HIGH-/LOW-PRESSURE SWITCH

The pressure switch functions automatically to open or close the compressor contactor coil circuit, upon increase or decrease of pressure to the switch.

To replace the pressure switches, located on the compressor service valves, the compressor refrigerant pressure must be reduced to 0 to 0.1 bar.

1. To do this, close the suction service valve on the compressor, and run the compressor, until the pressure is stabilized at 0 to 0.1 bar.
2. Switch OFF the unit. Close the compressor discharge service valve on the compressor.
3. Release any remaining pressure in the compressor by slowly loosening the gauge port caps on the service valve.
4. Replace defective switch.
5. If the switch exchange is completed within 5 minutes, purging the compressor for air will not be necessary because the refrigerant mixed in the compressor oil will continue to boil off and create positive pressure in the compressor, which will prevent air from entering.
6. Open suction and discharge service valves on the compressor and replace stem caps.
7. Connect pressure switch electrical wires.

7.6 THERMAL EXPANSION VALVE

The expansion valve on the unit consists of two parts:

1. The nozzle/filter
2. The power element, which is part of the body, and the thermal-sensing bulb, which is attached to the top of the power assembly by a capillary tube, allows the power element to be controlled by temperature changes in the bulb. In addition to this, a 1/4 in. copper tube connects the valve to the suction line, which serves as an equalizer.

The thermal bulb is secured to a pre-selected point on the suction line and is positioned at 4 or 8 o'clock, by the perforated metal straps. If, for any reason, the bulb is removed from the suction line, care must be taken to ensure the bulb is replaced correctly.

It is seldom that an expansion valve fails and even less often that it needs adjustment. Superheat is pre-set and should not need attention after installation.

The expansion valve is pre-set by the manufacturer to operate at 9°C superheat on max. capacity. No attempt should be made to adjust this setting. Non-compliance to this could cause a reduction in system capacity and may damage the compressor and void the warranty.

If, at initial start-up of the system, a particle of dirt becomes lodged in the valve, it will be necessary to pump down the system and dismantle the valve cage/filter to remove the particle.

7.7 CRANKCASE PRESSURE REGULATOR

For operation with high box temperature, a crankcase pressure regulator is mounted in the suction pipeline, to protect the compressor motor against overload.

TO ADJUST REGULATOR

1. Connect service pressure gauge to the compressor suction service valve.
2. Start unit. (**NOTE.** Can only be adjusted with container temperature between 20° and 0°C)
3. Remove protection cap on the pressure regulator.
4. With an Allen wrench turn the adjustment stem clockwise to raise or counterclockwise to lower the valve setting. Correct setting is max. suction pressure 3.0 bar.
5. Replace protection cap on pressure regulator.

7.8 LIQUID SOLENOID VALVE

Option not used if compressor section is mounted on container front wall.

The solenoid valve (NC) in the system is mounted in the liquid line and operates by a signal from the controller. When the solenoid coil is energized, it directs refrigerant to the expansion valve.

TO REPLACE OR REPAIR VALVE

1. Close the liquid line shut-off valve, and pump down the system until the suction pressure stabilizes between 0 and 0.1 bar. (The valve must be open.) Remove all power to unit, then front seat the suction service valve on the compressor.
2. Remove cap and coil.
3. Slowly loosen bolts on the solenoid valve body to release any refrigerant that may be left in the lines.
4. Remove enclosing tube slowly, check for foreign material in the valve.
5. Replace defective parts.
6. Re-install all valve parts.
7. If the repair/exchange is completed within 5 minutes, purging the system for air will not be necessary because the refrigerant mixed in the compressor/evaporator coil will continue to boil off and create positive pressure in the system, which will prevent air from entering.
8. Open the liquid line shut-off valve and suction service valve and the unit is ready to start again.
9. Check for leaks.

7.9 NON-RETURN VALVE

The non-return valve in the system, is mounted in the discharge line, to prevent back flow from the condenser coil to the compressor.

TO REPLACE THE VALVE

The total refrigerant charge must be removed for the system. After the re-install, follow the normal evacuating and charging of the system.

7.10 LIQUID INJECTION VALVE COMPRESSOR

The liquid injection valve is pre-set by the manufacturer to control that temperature of the compressor will not rise above approximately 90°C.

Non-compliance to this could cause a reduction in system capacity and may damage the compressor and void the warranty.

TO REPLACE VALVE

1. Close the shut-off valve in the liquid line and pump down the system, until the suction pressure stabilizes between 0 and 0.1 bar. Remove all power to unit, then front seat the suction service valve.
2. Slowly loosen bolts on the valve body to release any refrigerant that may be left in the system.
3. Replace defective valve.
4. Install new valve.
5. If the repair/exchange is completed within 5 minutes, purging the system for air will not be necessary because the refrigerant mixed in the compressor/evaporator coil will continue to boil off and create positive pressure in the system, which will prevent air from entering.
6. Open the liquid line shut-off valve and suction service valve and the unit is ready to start again.
7. Check for leaks.

7.11 EMERGENCY SWITCH

(Inside container/chamber)

If the emergency switch (ES) is activated, the main circuit breaker switch will be switch OFF. (Unit stopped completely.)

For restarting the unit, the emergency switch must be reset before the main switch can be activated.

7.12 OVERHEAT, SAFETY SWITCH

Two overheat safety switches, (OHSR-OHSL) right and left side, are mounted in the heating section. If overheating occurs, e.g. hanging heat relay, the main circuit breaker switch will be switched OFF.

(Unit stopped completely.)

The switches open when temperature rises to 98°C, and reset automatically when temperature falls to app. 70°C.

For restarting the unit, the overheat safety switch must be reset before the main switch can be activated.

TO REPLACE OVERHEAT SAFETY SWITCH

1. Disconnect wiring.
2. Remove clamps from the overheat safety switch.
3. Insert new switch.
4. Connect wiring and make sure the wire is firmly connected.

7.13 OVERHEAT SWITCH

Two overheat switches, one on relay H1-H3 (OHR) and one on relay H2-H4 (OHL), are mounted in the heating section and will open the heating circuit if overheating, above 110°C occurs. The switch is reset automatically when temperature falls to 38°C.

TO REPLACE OVERHEAT SWITCH

1. Disconnect wiring.
2. Remove two screws from the overheat switch.
3. Insert new switch.
4. Connect wiring and make sure the wire is firmly connected.

SECTION 8. ALARM AND TROUBLE SHOOTING

8.1 GENERAL INFORMATION

Several components are incorporated in the unit to assist the service engineer to find the cause of problems concerning the operation and efficiency of the unit.

The alarm light on the display panel indicates if the unit has an alarm.

The display panel (in "main menu" mode) indicates what the micro-processor controller is calling for and should be used in conjunction with pressure gauges to determine whether certain cycles are operating.

NOTE: It is recommended to initiate the manual test after all repairs. The alarm light on the display panel will be lit until the failure is repaired. **(Alarm not active, will be cancelled after one-hour delay.)**

8.2 ALARM/TROUBLE SHOOTING

ALARM CHART

"ALARM" LAMP LIGHT ON, GO TO "ALARM" IN MAIN MENU, (PRESS (→) FOR ENTER.) THE DISPLAY SHOWS ACTIVE ALARM CODE:		
SCROLL, PRESS (↓) OR (↑)	PRESS (→) FOR CANCEL	ESC. PRESS (←)
No. alarm	Description	Corrective Action
Surface sensor out of range. A01	Surface air sensor has an open (999.9°C) or short (-99.9°C) circuit. (Unit switches to storing.)	Repair or replace defective part.
Center sensor out of range. A02	Center sensor has an open (999.9°C) or short (-99.9°C) circuit. (Unit switches to storing.)	Repair or replace defective part.
Return sensor out of range. A03	Return air sensor has an open (999.9°C) or short (-99.9°C) circuit. (Unit continues operating.)	Repair or replace defective part.
Supply sensor out of range. A04	Supply air sensor has an open (999.9°C) or short (-99.9°C) circuit. (Unit continues operating.)	Repair or replace defective part.
Defrost sensor out of range. A05	Defrost sensor has an open (999.9°C) or short (-99.9°C) circuit. (Unit continues operating.)	Repair or replace defective part.
Condenser sensor out of range. A06	Condenser sensor has an open (999.9°C) or short (-99.9°C) circuit. (Condenser fan operates constant.)	Repair or replace defective part.
Compressor sensor out of range. A07	Compressor sensor has an open (999.9°C) or short (-99.9°C) circuit. (Compressor operating, without safety overheat cut-out.)	Repair or replace defective part.
"Reference error" shut down. A17	Internal controller error. Unit shutdown.	Repair or replace defective part.
Evaporator temp. too low. A18 (Only active if "Demand defrost" is set to ON. See Switch setting.)	If the Evaporator temperature is 10°C below the Return air temperature, for more than 300 sec, the Unit will run a defrost cycle, but if it's only 15 min. since last defrost the alarm A18 will be set. (After alarm is set, the unit will only operate with timer defrosting.)	Check - repair or replace defective Evap. / Return sensor.
	Blocked airflow in chamber.	Check free airflow.
	Overload relay "OL1" has tripped to OFF position.	Reset / check / replace defective relay.
	Defective fan motor relay FRL.	Repair or replace defective relay.
Surface sensor too low. A19	Surface sensor is not placed correctly	See note, CONTROLLER SEQUENCE. Section 5.2

Surface temperature too high. A20	Surface sensor, more than 5°C above set point in 5 min. (Only thawing, Unit switches to storing.)	Sensor not placed on product. See instruction for surface sensor.
	Defective refrigerant system.	Check- repair or replace defective part.
	Blocked airflow in chamber.	Check - free airflow.
Return temperature too high. A24	Under thawing: Return sensor, more than 5°C above set point in 5 min. (Unit switches to storing.) Under storing: Return sensor temperature must fall more than 1°C per hour. (Unit continues operating but gives alarm.)	Check - repair or replace defective sensor.
	Defective refrigerant system.	Check - repair or replace defective part.
Supply temperature too high. A26	Supply sensor, more than 10°C above Return sensor, in 5 min. (Unit switches to storing.)	Check - repair or replace defective sensor.
	Blocked airflow in chamber.	Check - free airflow.
Center temp. rises too fast. A27	Sensor not placed correctly in product for messaging of center temperature. Center sensor, reaches set point temperature in less than 30 min. (Thawing cycles lower than 30 min. Unit switches to storing.)	Place sensor correctly in center of product.
Surface temp. rises too fast. A28	Sensor not placed correct on product for messaging of surface temperature. Surface sensor, reaches 1°C below set point temperature in less than 15 min. (Thawing cycles not complete, Unit continues operating.)	Place sensor correctly on surface of product.
Defrost time too long. A32	Check louver on evaporator supply air side.	Replace defective part.
	Check amperage on heat step H1.	Replace defective part.
	Check heat step H1 relay and solid-state relay H1S.	Replace defective part.
	Defrosting stops on timer. (Longer defrosting than max. defrost time in "Config", factory set is 30min.)	Terminate defrost.
Comp. temperature too high. A33	Compressor discharge line temperature above 120°C. (Unit shuts down compressor.)	Check - repair or replace defective sensor.
	Defective refrigerant system.	Refrigerant charge.
	To high condensing temperature.	Clean condenser/check condenser fan motors and fans.
	Defective liquid injection valve	Repair or replace defective part.
Fan right, feedback missing. A34 (No feedback signal from fan relay.)	Overload relay "OL2" has tripped to OFF position. (Unit stops heat step H1 and H3.)	Reset / check / replace defective relay.
	Defective fan relay FRH.	Repair or replace defective relay
	Fan door safety switch, FDS open. (Unit continues operating.)	Reset / check / replace defective switch.
Fan right, feedback hanging. A35 (feedback signal, from fan relay hanging.)	Defective fan motor relay FRH.	Repair or replace defective relay.
Fan left, feedback missing. A36 (No feedback signal from fan relay.)	Overload relay "OL3" has tripped to OFF position. (Unit stops heat step H2 and H4.)	Reset / check / replace defective relay.

	Defective fan relay FL.	Repair or replace defective relay
	Fan door safety switch, FDS open.	Reset / check / replace defective switch.
Fan right, feedback hanging. A37 (feedback signal, from fan relay hanging.)	Defective fan motor relay FL. (Unit continues operating.)	Repair or replace defective relay.
Auto test arrow, amperage too low. A40	Current of one of the tested parts is too low. (See Event log for fail, if alarm.)	Check amperage on the failed part with an ammeter. Repair or replace defective part.
Auto test arrow, amperage too high. A41	Current of one, of the tested parts is too high. (See Event log for fail, if alarm.)	Check amperage on the failed part with an ammeter. Repair or replace defective part.
Auto test arrow, delta amperage too high. A42	The difference in current of one of the tested parts is too high. (See Event log for fail, if alarm.)	Check amperage on the failed part with an ammeter. Repair or replace defective part.

MESSAGE INFORMATION IN DISPLAY

DISPLAY SHOWS:	Description
Surface sensor too high M01	Surface sensor more than 5° C above set point.
Return sensor too high M02	Return sensor more than 5° C above set point.
Supply sensor too high M03	Supply sensor more than 10° C above Return sensor.
Surface sensor too low M04	Surface sensor does not reach set point, in the normal time scale.
Fan right, feedback missing. M07	No feedback from fan relay. (FRH)
Fan right, feedback hanging. M08	Fan relay hanging (FRH)
Fan left, feedback missing. M09	No feedback from fan relay. (FL)
Fan left, feedback hanging. M10	Fan relay hanging (FL)
Comp. temp. too high. M11	Compressor discharge line temp above 120°C.
Small diff. M16	Difference in set point between the Surface and Center sensor temperature must be more than 1°C. If the setting is lower, the Controller will not accept the program setting.

TROUBLE SHOOTING

The following trouble shooting chart is by no means complete but covers general type of problems which are most likely to occur if a breakdown is experienced.

Trouble	Possible Cause	Corrective Action
No power to system. (No light in "POWER ON" lamp)	Fault in power cable or connection. Circuit breaker CB1 or CB2 in the "OFF" position.	Replace or repair. Put CB1 or CB2 in the "ON" position.
Power OK. to system, but light in "POWER ON" lamp, and nothing operates with unit ON/OFF switch, in "ON" position.	Missing 28V and/or 24V from transformer. Circuit breaker CB3 has tripped to "OFF" position. Defective ON/OFF switch. Check all overload relays.	Check input and output of transformer and replace if necessary. Reset CB3 Replace or repair. Reset overload relays.
"POWER ON" and "ALARM" lamps light, but unit does not operate, when ON/OFF switch is put in the "ON" position.	Controller defect, or defective wire/plug to controller. Defective ON/OFF switch	Repair or replace defective part Repair or replace defective part.
"POWER ON" lamp light, but unit does not operate when ON/OFF switch is put in the "ON" position.	One or more of overload relays has tripped to "OFF" position. One or more defective relay.	Reset overload relays. Repair or replace defective part.

Trouble	Possible Cause	Corrective Action
"POWER ON" lamp lights, but the compressor does not operate, when ON/OFF switch is put in the "ON" position	Compressor internal overheat switch has cut-out.	Check compressor wire connection, (wait for compressor to cool down)
	High-pressure switch cut-out.	Check / replace defective switch.
	Low-pressure switch cut-out.	Check / replace defective switch.
	Defective compressor relay.	Repair or replace defective relay.

8.3 UNIT INFORMATION

ELECTRICAL

Electrical All data are approximate, and based on 480V/60 Hz	
Input power	480V, 3 phase, 60Hz.
Current total unit	Full load – 75A
Compressor motor	3450 Rpm - full load – 12.5A
Condenser motor	1100 Rpm - full load – 1.2A
Fan right, high speed	850 Rpm - full load – 7A
Fan right, low speed	425 Rpm - full load – 3A
Fan left	850 Rpm - full load – 7A
Heat step 1	13.5 kW - full load – 20A
Heat step 2	9 kW - full load – 16A
Heat step 3	9 kW - full load – 16A
Heat step 4	9 kW - full load – 16A

REFRIGERANT

Refrigerant System	
System charge: R-404A or R-452A	3.7 kg (8.2 lbs) 3.9 kg (8.6 lbs)
Compressor oil charge	3.2 Liter (9.5 gal)
High-pressure switch (cannot be adjusted)	Cut-out approx. 28 bar +/-0.7 = 406 Psig +/- 10 Cut-in approx. 20 bar +/-0.3 = 290 Psig +/- 4.35
Low-pressure switch (cannot be adjusted)	Cut-out approx. -0.4 bar +/-0.2 = 11 HG +/- 2.9 Psig Cut-in approx. 0.3 bar +/-0.3 = 4.35 Psig +/- 4.35
Crankcase pressure regulator	Set to suction pressure at max. 3 bar. = 43.5 Psig
Safety Relief valve (cannot be adjusted)	29.3 bar. = 425 Psig

UNIT CAPACITY

Test method according to ARI standard no. 1110-69 approval. Net cooling capacity at 30°C ambient temperature, 50Hz power.		
Return Air Temperature	Capacity	Power Requirement
Storage -20°C	5.5 kW	6.6 kW
Storage +/-0°C	8.5 kW	9.1 kW
Thawing +40°C	46 kW	47 kW

Unit capacity increases approximately 15% when operating at 60Hz.

KLINGE CORPORATION

Address: 4075 East Market Street York, PA 17402-5100 USA

Telephone: 717.840.4500 Telefax: 717.840.4501

Corporate website - www.klingecorp.com



SECTION 9 SERVICE PARTS

- 9.1 Heat-Evaporator Section Front View
- 9.2 Heat-Evaporator Section Open View
- 9.3 Compressor-Condenser
- 9.4 Electrical Box Inside
- 9.5 Electrical Box Labels and Circuit Breaker Handle
- 9.6 Display Box
- 9.7A Miscellaneous Parts
- 9.7B Miscellaneous Parts
- 9.8 Temperature Conversion Tables
- 9.9A Standard Composite Room Ceiling
- 9.9B Pallet Wide 40FT Container Ceiling
- 9.9C Standard 40FT Container Ceiling

9.1 HEAT-EVAPORATOR SECTION FRONT VIEW

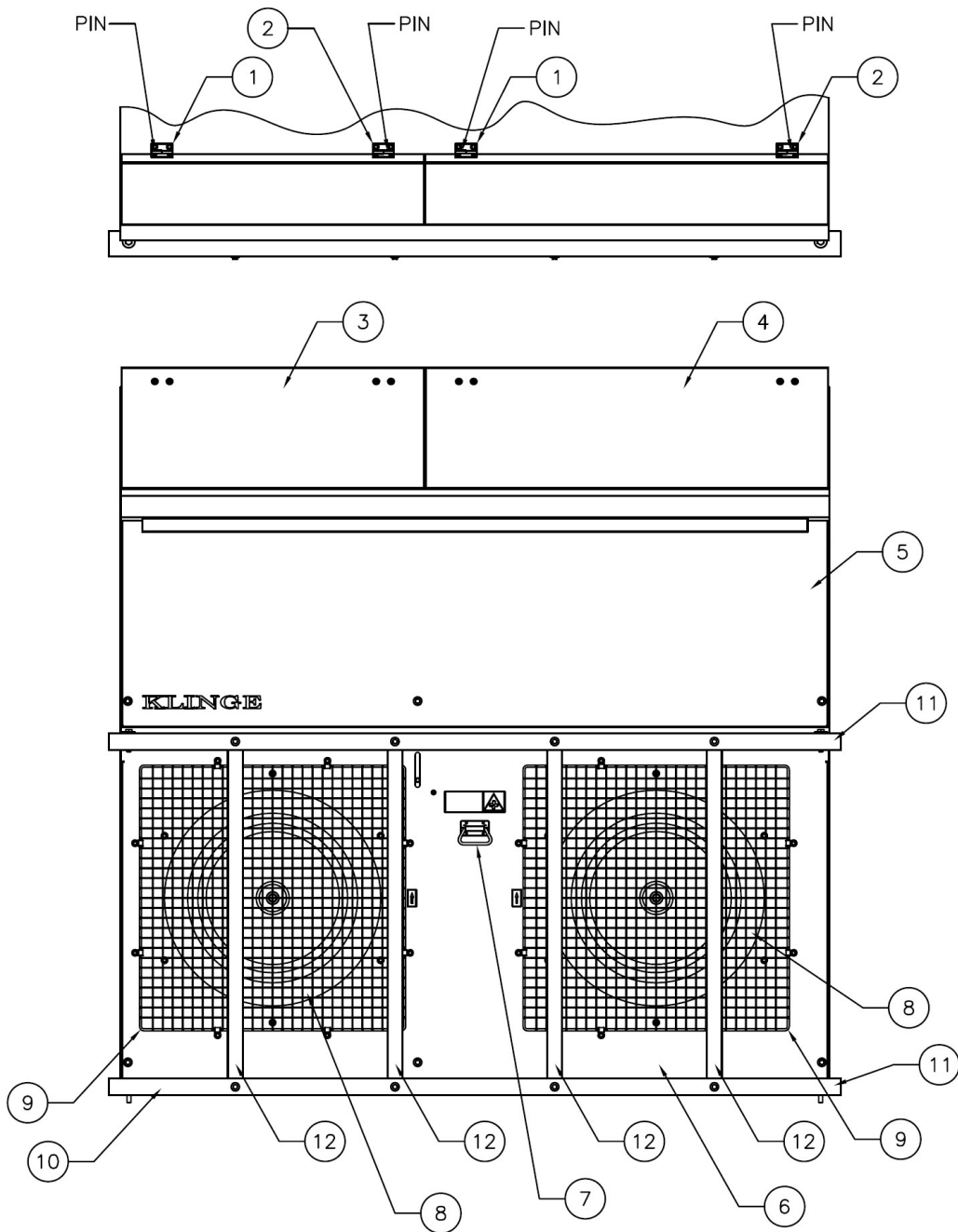

**SECTION 9.1
HEAT-EVAPORATOR SECTION FRONT VIEW**

9.1 HEAT-EVAPORATOR SECTION FRONT VIEW

ITEM	PART NO.	DESCRIPTION	QTY.
1	K29-17879-02	HINGE SLIP SS 9/32 HOLES WITH PIN	2
2	K29-17880-02	HINGE SLIP SS 9/32 HOLES WITH PIN	2
3	360-17898-01	DAMPER AIR WARM SECTION	1
4	360-17897-01	DAMPER AIR COOL SECTION	1
5	360-17893-01	COVER ACCESS HEATERS QTU-42 WITH LABEL	1
6	360-17894-00	COVER ACCESS BLOWER SECTION	1
		(INCLUDES ITEMS #7, #8, AND #9)	
7	K29-18375-00	HANDLE 2" CHEST 304SS WITH 4 HOLES	1
8	360-17896-01	INLET RING MODIFIED BLOWER SECTION	2
9	K26-25251-00	GRILL WIRE SQUARE 800mm x 800mm	2
10	360-17887-00	PALLET STOP QTU-42	1
		(INCLUDES ITEMS #11, AND #12)	
11	060-17888-00	ANGLE PALLET STOP	2
12	060-17889-00	CHANNEL PALLET STOP VERTICAL	4

9.2 HEAT-EVAPORATOR SECTION OPEN VIEW

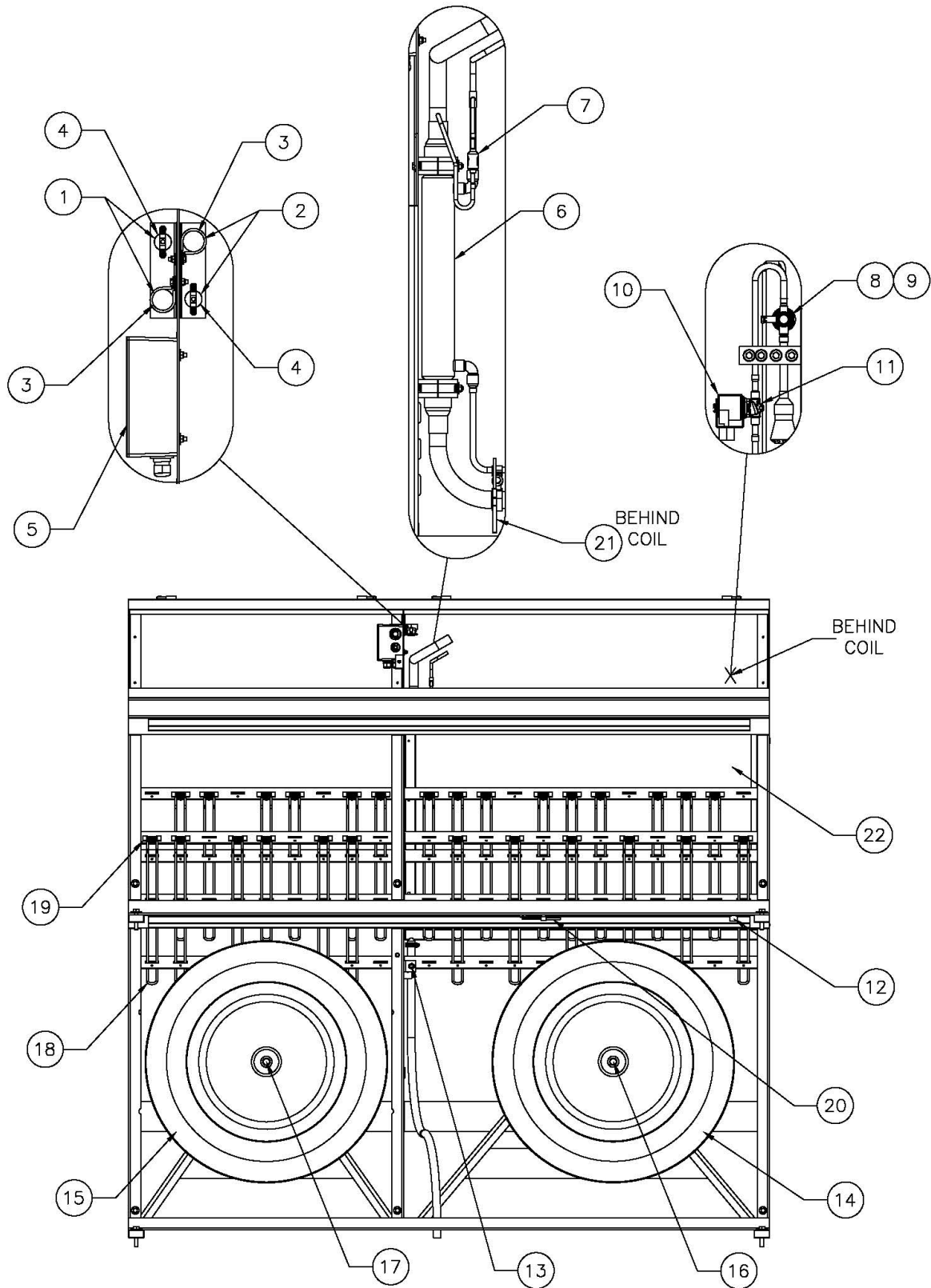

**SECTION 9.2
HEAT-EVAPORATOR SECTION OPEN VIEW**

9.2 HEAT-EVAPORATOR SECTION OPEN VIEW

ITEM	PART NO.	DESCRIPTION	QTY.
1	360-17545-01	CABLE TEMPERATURE CONTROL LEFT	1
		(INCLUDES ITEMS #3 AND #4 QTY 1 EACH)	
2	360-17545-02	CABLE TEMPERATURE CONTROL RIGHT	1
		(INCLUDES ITEMS #3 AND #4 QTY 1 EACH)	
3	K15-00042-00	THERMOSTAT KIT COMPR DISCH 1/2 NC OPEN 220 COSE 170	2
4	K25-19557-00	CONTROL TEMPERATURE 130F OPEN 100F CLOSE	2
5	360-17912-00	JUNCTION BOX EVAP QTU-42	1
6	K26-25297-00	HEAT EXCHANGER 1/5/8 C 5/8 LIQ	1
7	K22-04392-02	CHECK VALVE 1/4 ID BRASS	1
8	K25-26547-00	TX VALVE 3/8 IN 1/2 OUT 1/4 EQUAL	1
9	K25-26609-00	ORFICE TX VALVE TUAE SIZE TU8	1
10	360-17544-01	COIL SOLENOID LIQUID	1
11	K25-26778-02	VALVE SOLENOID 3/8 EVR 6 LESS COIL	1
12	360-17538-00	PROBE CARGO PLUG	1
13	360-17543-00	SWITCH DOOR EVAPORATOR	1
14	K26-25249-01	IMPELLER ALUM TYPE 800 CW 38MM DIA HUB	1
15	K26-25249-02	IMPELLER ALUM TYPE 800 CCW 38MM DIA HUB	1
16	360-18788-00	MOTOR 2.2 KW DUAL SPEED 8-16P 60 HZ IEC 132S B3	1
		(FOR USE WITH 60 HZ UNIT)	
16	360-18790-00	MOTOR 2.8/0.45 KW DUAL SPEED 6-12P 50 HZ IEC 132S B3	1
		(FOR USE WITH 50 HZ UNIT)	
17	360-18787-00	MOTOR 2.2 KW 850 RPM 60 HZ IEC 132S B3	1
		(FOR USE WITH 60 HZ UNIT)	
17	360-18789-00	MOTOR 3.0 KW 900 RPM 50 HZ IEC 132S B3	1
		(FOR USE WITH 50 HZ UNIT)	
18	K25-26886-00	HEATER 440V 1500W	27
19	060-17892-00	BRACKET RETAINING HEATER	27
20	360-17539-00	PROBE RETURN QTU-42	1
21	360-17540-00	PROBE DEFROST	1
22	360-17856-00	COIL MODIFIED QTU-42	1

9.3 COMPRESSOR-CONDENSER

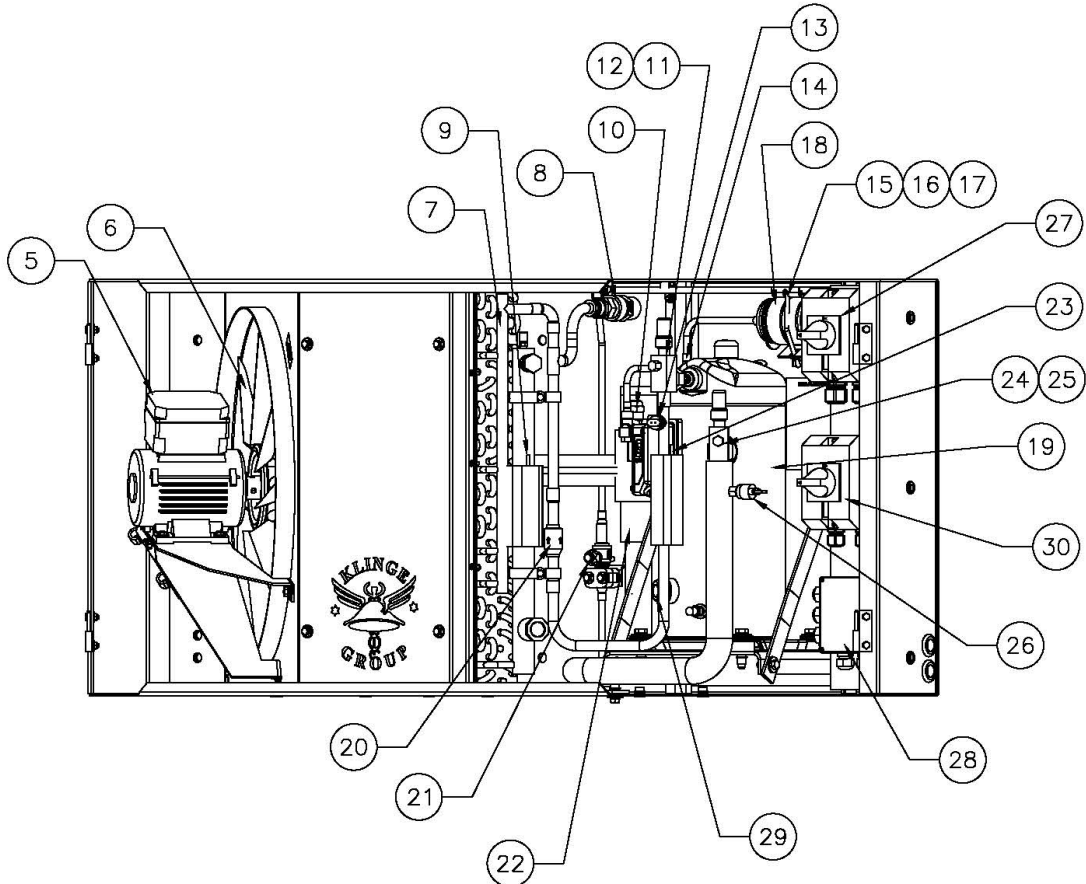
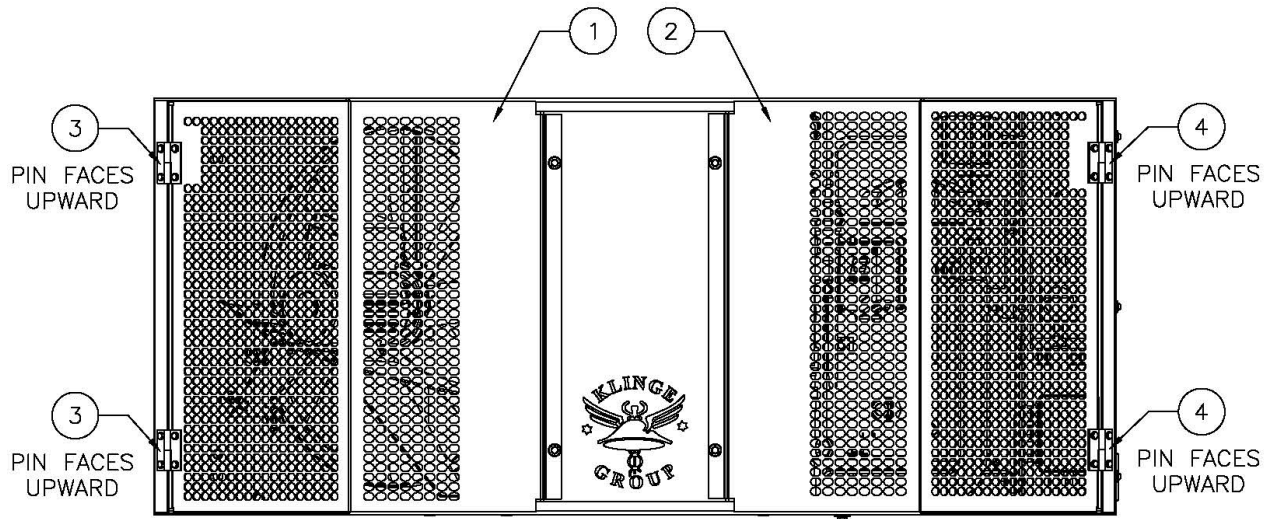

SECTION 9.3 COMPRESSOR-CONDENSER

9.3 COMPRESSOR-CONDENSER

ITEM	PART NO.	DESCRIPTION	QTY.
1	360-17950-01	COVER HINGED CONDENSER LEFT	1
2	360-17950-02	COVER HINGED CONDENSER RIGHT	1
3	K29-17880-02	HINGE SLIP SS 9/32 HOLES WITH PIN	2
4	K29-17879-02	HINGE SLIP SS 9/32 HOLES WITH PIN	2
5	360-17550-00	MOTOR ASSEMBLY CONDENSER	1
6	K26-25230-01	FAN 21.65" 14MM X 5MM KEYWAY 8 BLADE 35 DEG PITCH PULL	1
7	360-17952-00	COIL CONDENSER MODIFIED QTU-42	1
8	K22-07028-01	VALVE SAFETY RELIEF 29.3 BAR (425 PSIG)	1
9	360-17542-00	PROBE CONDENSER QTU-42	1
10	K15-00042-13	KIT VALVE DTC DISCH TEMP CONTL 3/8 CUP FOR SCROLL	1
11	K22-06970-00	VALVE ROTALOCK 1-14 X 5/8 C BRASS	1
12	K28-08249-00	SEAL TEFLON ,75" OD .63" ID .062 THK FOR ROTALOCK 1-14	1
13	360-16405-20	SWITCH HIGH-PRESSURE	1
14	K26-25116-00	INDICATOR MOISTURE 3/8 C	1
15	060-06902-00	BRACKET DRYER MOUNTING	1
16	360-56093-00	BOLT DRYER MOUNTING M6 PASSIVATE	1
17	K21-50101-06	NUT WING SS M6	1
18	K26-25215-00	FILTER DRYER 3/8 CUP 163-S	1
19	360-17552-00	COMPRESSOR CONDENSER QTU-42	1
20	K26-58023-30	CHECK VALVE 5/8C X 5/8C	1
21	K22-07030-02	VALVE SHUT-OFF 3/8C X 3/8/C	1
22	K22-06950-03	SUCTION REGULATOR 1-1/8 SHT	1
23	360-17541-00	PROBE DISCHARGE QTU-42	1
24	K22-06910-00	VALVE ROTALOCK 1-1/4-12 X 7/8 C BRASS	1
25	K28-04836-00	SEAL TEFLON 1" OD .88" ID .062 THK FOR ROTALOCK 1-1/4-12	1
26	360-16405-19	SWITCH LOW-PRESSURE	1
27	360-18310-00	SWITCH ASSEMBLY COMPRESSOR MAIN 16 AMP 3 POLE	1
28	360-17956-00	BOX JUNCTION COND QTU-42	1
29	K15-00042-17	SIGHT GLASS	1
30	360-18309-00	SWITCH ASSEMBLY CONDENSER MAIN 16 AMP 3 POLE	1

9.4 ELECTRICAL BOX INSIDE

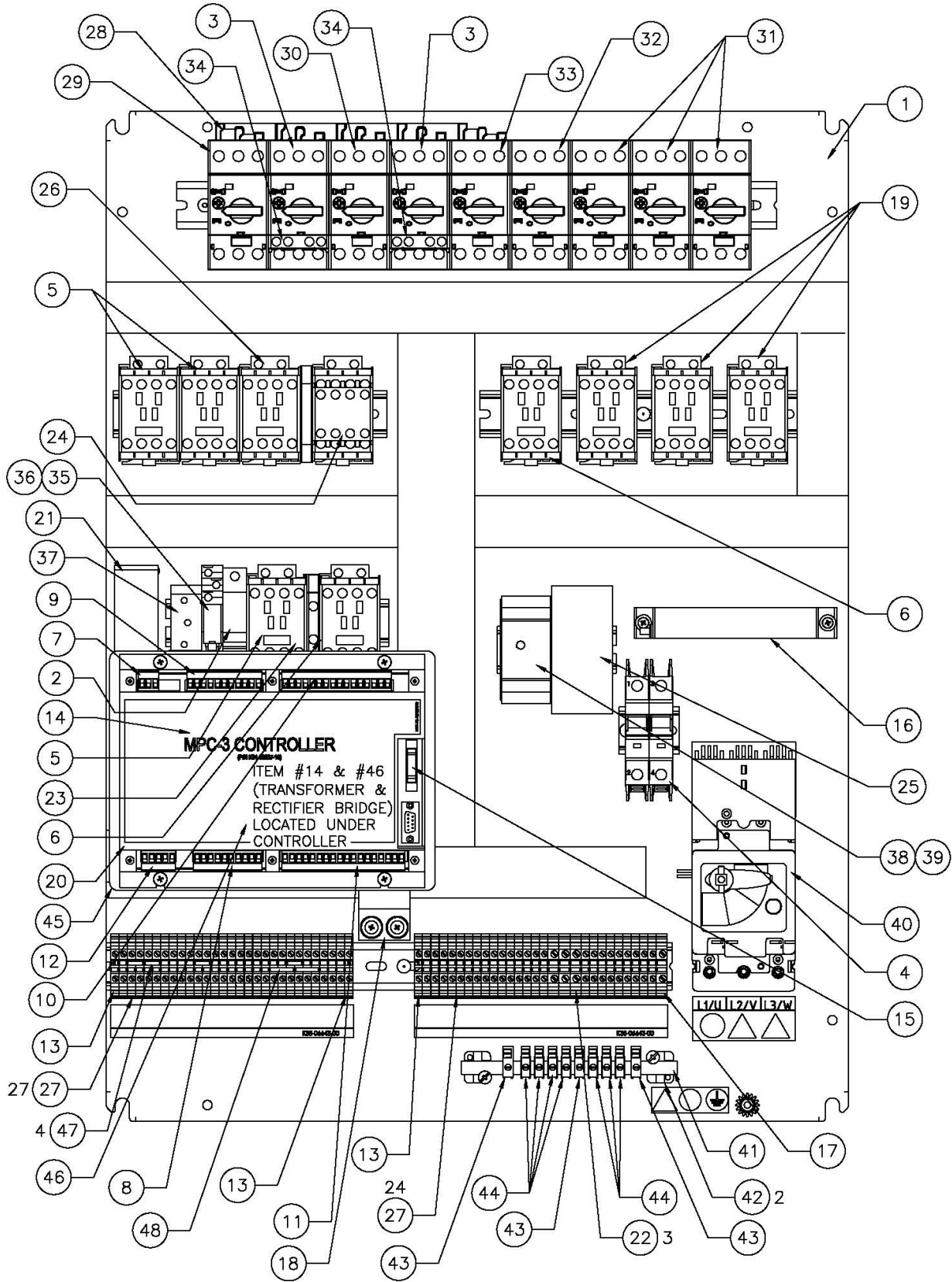

SECTION 9.4
ELECTRICAL BOX INSIDE

9.4 ELECTRICAL BOX INSIDE

ITEM	PART NO.	DESCRIPTION	QTY.
1	360-17505-00	ELECTRICAL BOX MODIFIED WITH OUT COMPONENTS	1
2	K24-22361-06	CIRCUIT BREAKER 6 AMP	1
3	K24-22361-09	CIRCUIT BREAKER OVERLOAD 6.3 - 10.0 AMP	2
4	K24-22543-01	CIRCUIT BREAKER 1 AMP 2 POLE 480 VAC	1
5	K24-58160-03	CONTACTOR 12A 3P 24V/29V 50/60 HZ	3
6	K24-58160-05	CONTACTOR 25A 3P 24V 50/ 29V 60 HZ	2
7	K25-25733-00	BLOCK TERMINAL M3 3 POS 12 AMP MSTB 2, 5/3-ST-5,08	1
8	K25-25733-02	BLOCK TERMINAL M3 10 POS 12 AMP MSTB 2, 5/10-ST-5,08	1
9	K25-25733-03	BLOCK TERMINAL M3 11 POS 12 AMP MSTB 2, 5/11-ST-5,08	1
10	K25-25733-04	BLOCK TERMINAL M3 16 POS 12 AMP MSTB 2, 5/16-ST-5,08	1
11	K25-25733-05	BLOCK TERMINAL M3 18 POS 12 AMP MSTB 2, 5/18-ST-5,08	1
12	K25-26532-05	PLUG COMBINATION 5 PIN .2 PTCH STR	1
13	K25-26739-06	TERMINAL K4 GROUND GREEN	3
14	K25-26741-00	TRANSFORMER 480/28-4,6A/ 24-1A/ 20-1A.166AVA. (UL/CSA)	1
15	K25-26742-00	MULTIPLUG 16 POLE (DISPLAY CABLE)	1
16	K25-26743-00	TRANSFORMER CURRENT 100 AMP 3 PHASE	1
17	K25-58645-06	TERMINAL UT6 GREEN	1
18	360-17513-00	SUPPORT WITH IMSERT MPC-3	1
19	K24-22156-00	CONTACTOR 16A 3P 460 VOLT 24 VAC 50/60 Hz COIL	3
20	K31-00927-10	CONTROLLER MPC3 LABELED	1
21	360-17793-10	BATTERY PACK 6V 2000mAH MPC3 RECHARGEABLE SIDE MTG	1
22	K25-26739-15	TERMINAL UT6 GRAY	3
23	K24-22176-02	CONTACT AUX NC	1
24	K24-22176-04	CONTACT AUXILIARY 4 POLE NORMALLY OPEN TOP MOUNT	1
25	K24-22520-00	RELAY SOLID STATE 30A ECI	1
26	K24-22321-01	CONTACTOR REVERSING 12A 6P 24/29 VAC	1
27	K25-26739-01	TERMINAL K4 GRAY	51
28	K25-26745-05	BAR BUS BBC 25 45-5	1
29	K24-22361-16	CIRCUIT BREAKER OVERLOAD 1.00 - 1.60 AMP	1
30	K24-22361-07	CIRCUIT BREAKER OVERLOAD 2.50 - 4.00 AMP	1
31	K24-22361-11	CIRCUIT BREAKER OVERLOAD 14.50 - 20.00 AMP	3
32	K24-22361-12	CIRCUIT BREAKER OVERLOAD 18.00 - 25.00 AMP	1
33	K24-22361-10	CIRCUIT BREAKER OVERLOAD 10.00 - 16.00 AMP	1
34	K24-22514-00	CONTACT AUX CBA-11	2
35	K24-22515-00	RELAY 24VAC COIL SPDT 10A G2R	2
36	K25-26889-00	SOCKET RELAY SPDT G2R-1-S	1
37	K24-22516-00	TIMER DELAY ON 10S TYPE EAS	1
38	K25-26890-00	SOCKET 11 PIN TYPE PF113	1
39	K24-22517-00	TIMER DELAY ON 10M TYPE EAS	1
40	360-17978-08	CIRCUIT BREAKER 80A 3P 480 VAC MAIN	1
41	060-17507-00	BAR BRS EARTH 10 X 3 X 160MM	1
42	K25-58737-01	HOLDER EARTH BAR	2
43	K25-58736-01	TERMINAL EARTH BAR TYPE ZBE6K GRN/YEL	3
44	K25-26900-00	TERMINAL EARTH BAR TYPE ZB4K GRN/YEL	7
45	360-17509-00	PLATE MOUNTING HINGED MPC-3	1
46	360-17646-00	RECTIFIER BRIDGE 1PH 25A 200V MTG TAPE 1"	1
47	K25-26992-02	JUMPER TERMINAL UT4 2-PIN	4
48	K25-26992-03	JUMPER TERMINAL UT4 3-PIN	2

9.5 ELECTRICAL BOX LABELS AND CIRCUIT BREAKER HANDLE

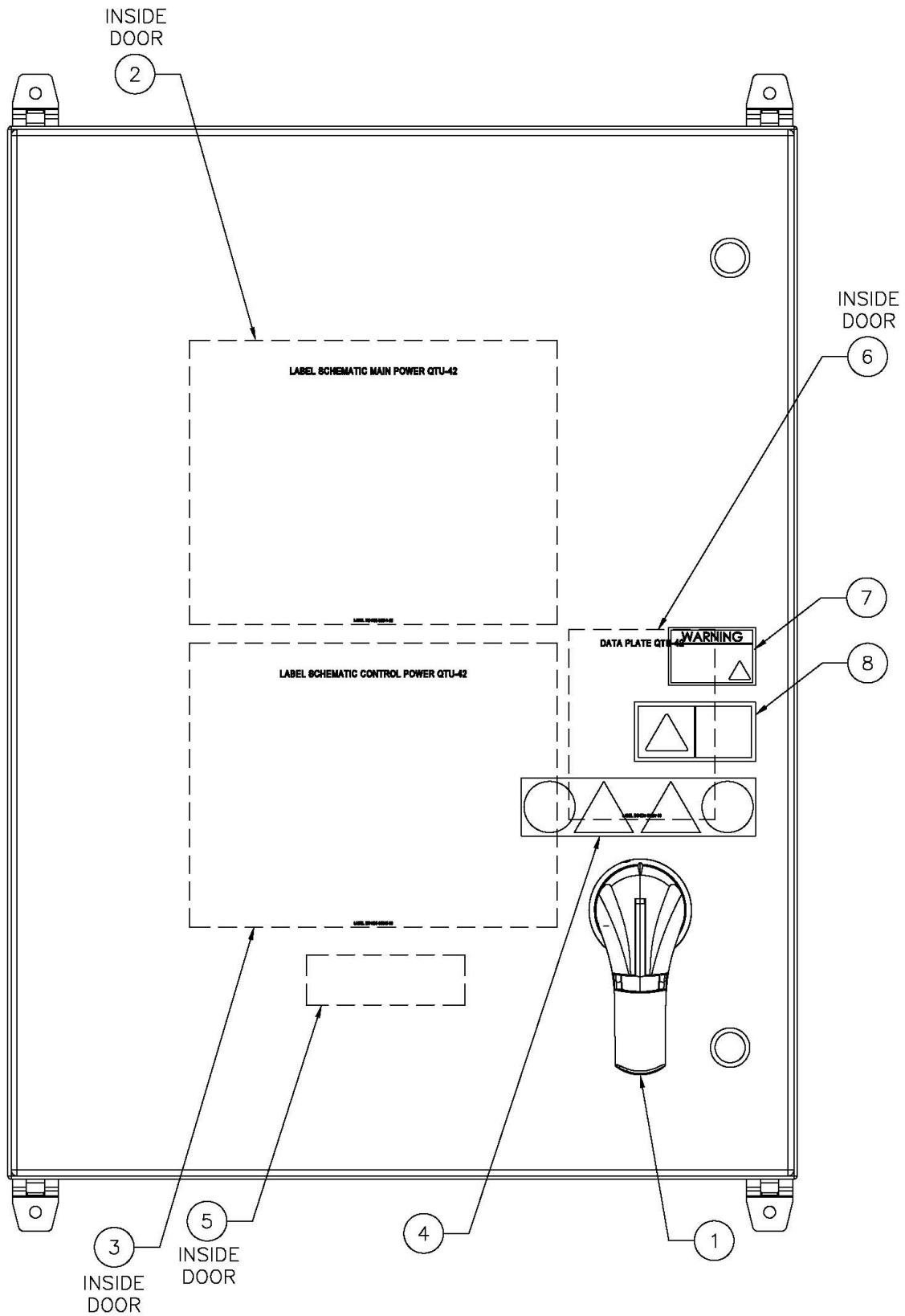

**SECTION 9.5
ELECTRICAL BOX
LABELS AND CIRCUIT BREAKER HANDLE**

9.5 ELECTRICAL BOX LABELS AND CIRCUIT BREAKER HANDLE

ITEM	PART NO.	DESCRIPTION	QTY.
1	K24-22526-13	KIT HANDLE AND ACTUATOR MAIN CIRCUIT BREAKER	1
2	K35-06614-00	LABEL SCHEMATIC MAIN POWER QTU-42	1
3	K35-06615-00	LABEL SCHEMATIC CONTROL POWER QTU-42	1
4	K35-06725-01	LABEL CONTROL BOX WARNING	1
5	K35-06209-00	LABEL KLINGE CORP. FOR TECH. ASSIST	1
6	K35-06617-00	LABEL DATA PLATE QTU-42	1
7	K35-06724-00	LABEL ANSIARC FLASH WARNING	1
8	K35-06723-00	LABEL HIGH VOLTAGE WARNING	1

9.6 DISPLAY BOX

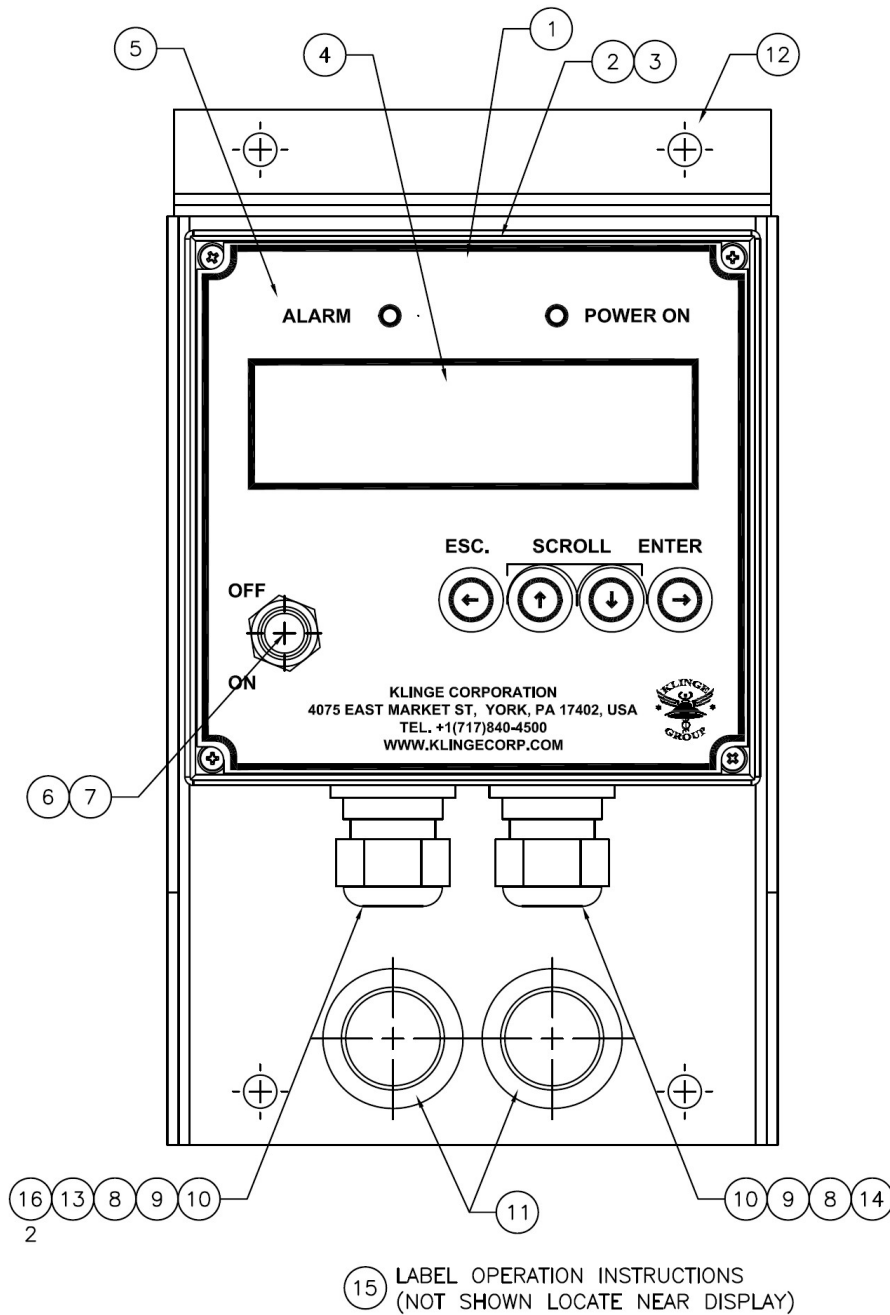

SECTION 9.6 DISPLAY BOX

9.6 DISPLAY BOX

ITEM	PART NO.	DESCRIPTION	QTY.
1	360-16424-01	DISPLAY MPC-3 COMPLETE	1
		(INCLUDES ITEMS #2, #3, #4, #5, #6, #7, #8, #9, AND #10	
2	360-17837-00	BOX DISPLAY BOTTOM SECTION MODIFIED	1
3	360-17836-00	BOX DISPLAY TOP SECTION WITH ADDED HOLES	1
4	K31-00929-10	DISPLAY TOUCH PAD CIRCUIT BOARD MPC-3 LABELED	1
5	K35-06460-00	LABEL DISPLAY BOX	1
6	K24-07458-00	TOGGLE SWITCH DPST ON-OFF 15A	1
7	K24-17239-00	BOOT TOGGLE SWITCH	1
8	K25-26129-07	CONNECTOR STRAIGHT PLASTIC SHORT 1/2 (.23-.54)	2
9	K25-26147-01	SEAL RING PLASTIC 1/2"	2
10	K25-26340-02	NUT LK CONDUIT 1/2"	2
11	K28-10847-05	GROMMET 1" HOLE	2
12	360-16489-10	PROTECTION BOX DISPLAY MPC-3 REMOTE	1
13	K25-26775-00	CORD ELEC RIBBON ROUND 16 CONDUCTOR SHIELDED	
		(ORDER IN FEET)	
14	K25-26355-00	CORD ELEC SO 16/6 0.52" OD	
		(ORDER IN FEET)	
15	K35-06616-00	LABEL OPERATING INSTRUCTIONS QTU-42	1
16	K25-26742-00	MULTIPLUG 16 POLE (DISPLAY CABLE)	2

9.7A MISCELLANEOUS PARTS

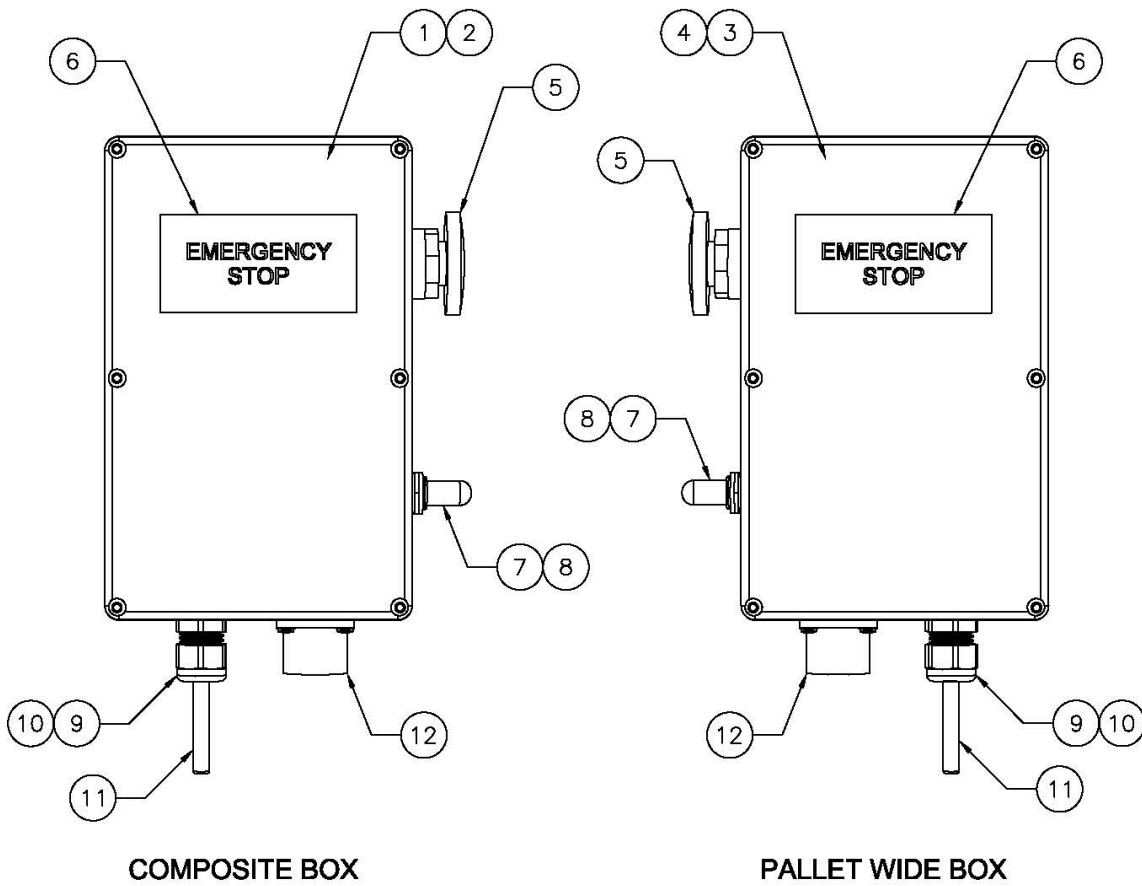

SECTION 9.7A MISCELLANEOUS PARTS

9.7A MISCELLANEOUS PARTS

ITEM	PART NO.	DESCRIPTION	QTY.
1	360-17518-10	BOX JUNCTION E-STOP AND COMPLETE (COMPOSITE)	1
		(INCLUDES ITEMS 2, AND 5 THROUGH 12)	
2	060-17519-10	BOX MODIFIED JUCTION E-STOP (COMPOSITE)	1
3	360-17518-15	BOX JUNCTION E-STOP AND COMPLETE (PALLET WIDE)	1
		(INCLUDES ITEMS 4 THROUGH 12)	
4	060-17519-15	BOX MODIFIED JUNCTION E-STOP (PALLET WIDE)	1
5	K24-22394-03	SWITCH PB SPST RED MUSHROOM (E-STOP)	1
6	K35-06369-03	LABEL EMERGENCY STOP 3 X 1.5	1
7	K24-07458-01	SWITCH TGL SPST ON-OFF 12V 15A 2-#6 SCR	
8	K24-17239-00	BOOT TGL SWITCH	1
9	K25-26129-01	CONNECTOR STRAIGHT PLASTIC SHORT 3/8 (.18-.31)	1
10	K25-26340-01	NUT LK CONDUIT BLK NYL 3/8" NPT	1
11	360-18452-00	PROBE SUPPLY NTC 2KOHM	1
12	360-17538-01	PLUG SURFACE PROBE	1

9.7B MISCELLANEOUS PARTS

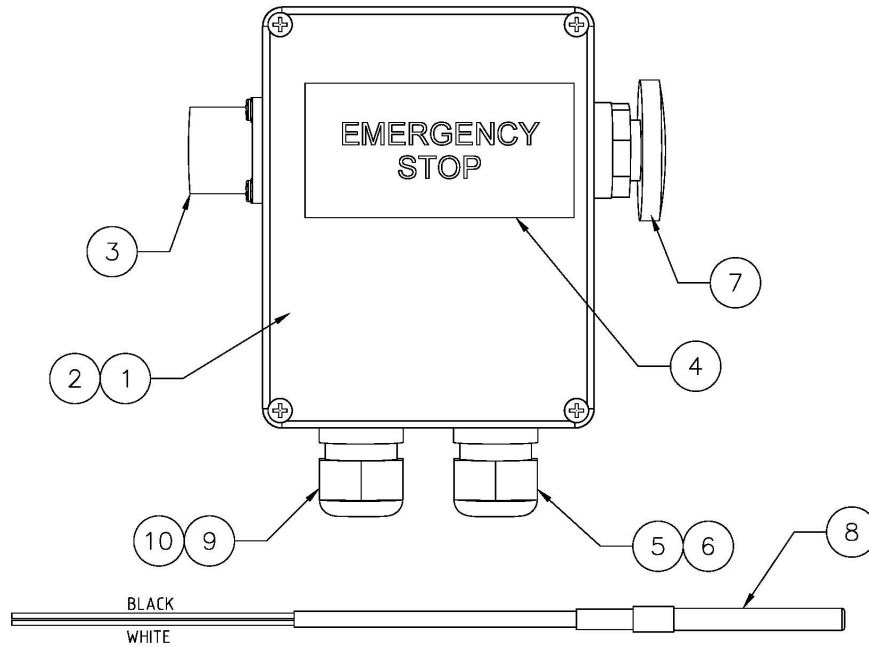

PROGRAM FOR THAWING UNIT QTU 42

PROGRAM NO.	PRODUCT NAME	SURFACE SENSOR Temperature From: 0° to +10°C [-32°F to +50°F]	CENTER SENSOR Temperature From: 10° to +5°C [-15°F to +43°F]	RETURN SENSOR Temperature From: 10° to +8°C [-10°F to +16°F]	STORING Temperature From: 30° to +15°C [22°F to +59°F]	UNIT DELAY Heat Thawing From 0 to 99 hours	UNIT DELAY Temperature From: 25° to 8°C [15°F to +17°F]
01							
02							
03							
04							
05							
06							
07							
08							
09							
10							
11							
12							
13							
14							
15							
16							
17							
18							
19							
20							

LABEL NO. K35-0600-00 REV. - 2/27/2015

Cleaning Instructions for Quick Thaw Units

CONTAINER	COILS AND HEATING	FRAME AND PANES
<p>WARNING:!! STOP UNIT BEFORE CLEANING</p> <p>Use only alkaline cleaning fluid that is approved for food industry and is suitable for stainless steel.</p> <p>Surfaces in direct contact with food items must be rinsed off thoroughly with water.</p> <p>When necessary, remove the container using the thorough rinsing.</p> <p>The maximum water temperature for cleaning must not exceed the container at 80°C (176°F).</p> <p>When using high pressure or steam pressure, maintain a minimum distance of 20cm (7.9 in) to the cleaning surface with the spray nozzle. Maximum pressure is 10 bar (145 psi). Maximum spray time on stainless steel is 30 seconds.</p>	<p>WARNING:!! STOP UNIT BEFORE CLEANING</p> <p>Use only alkaline cleaning fluid that is approved for food industry and is suitable for stainless steel.</p> <p>Surfaces in direct contact with food items must be rinsed off thoroughly with water.</p> <p>For access to the coil and heating elements, remove the access panel.</p> <p>The maximum water temperature for cleaning is 80°C (176°F).</p> <p>Do not spray directly onto sensitive components.</p> <p>When using high pressure or steam pressure, maintain a minimum distance of 20cm (7.9 in) to the cleaning surface with the spray nozzle. Maximum pressure is 10 bar (145 psi) and spray time on stainless steel is 30 seconds.</p>	<p>WARNING:!! STOP UNIT BEFORE CLEANING</p> <p>Use only alkaline cleaning fluid that is approved for food industry and is suitable for stainless steel.</p> <p>Surfaces in direct contact with food items must be rinsed off thoroughly with water.</p> <p>For access to the fan and electric lamps, remove the access panel on the fan.</p> <p>The maximum water temperature for cleaning is 80°C (176°F).</p> <p>Do not spray directly onto sensitive components.</p> <p>When using high pressure or steam pressure, maintain a minimum distance of 20cm (7.9 in) to the cleaning surface with the spray nozzle. Maximum pressure is 10 bar (145 psi) and spray time on stainless steel is 30 seconds.</p>

KLINGE CORPORATION
 4075 East Market Street, York, PA 17402 USA
 www.klinge.com
 For technical assistance please call (414) 773-6842 ext. 555
 For spare parts visit www.klingeusa.com or e-mail sales@klingeusa.com

LABEL NO. K35-0600-00 REV. - 2/27/2015

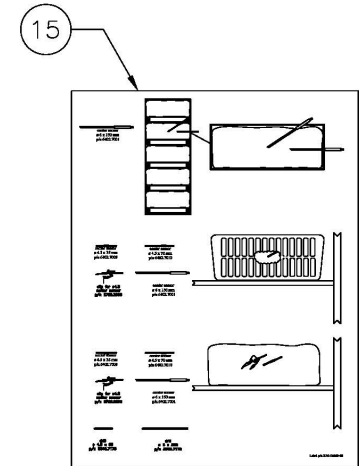
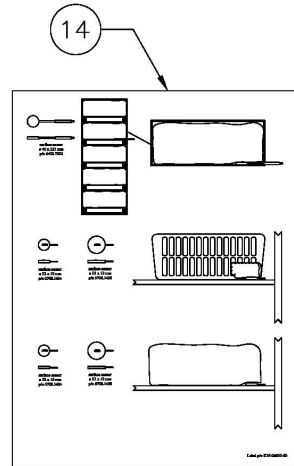
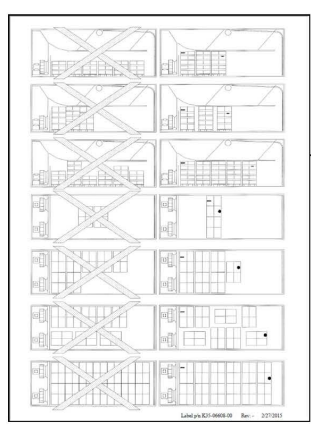

SECTION 9.7B MISCELLANEOUS PART

9.7B MISCELLANEOUS PARTS

ITEM	PART NO.	DESCRIPTION	QTY.
1	360-17518-00	BOX JUNCTION E-STOP AND PROBE QTU-42 COMPLETE (INCLUDES ITEMS #2, #3, #4, #5, #6, #7, AND #8)	1
2	060-17519-00	BOX MODIFIED JUCTION E-STOP AND PROBE	1
3	K25-52155-02	MULTIPLUG CA310E14S-2SBA176	1
4	K35-06369-03	LABEL EMERGENCY STOP 3 X 1.5	1
5	K25-26129-03	CONNECTOR STRAIGHT PLASTIC SHORT 1/2 (.17-.45)	2
6	K25-26340-02	NUT LK CONDUIT 1/2"	2
7	K24-22394-03	SWITCH PB SPST RED MUSHROOM (E-STOP)	1
8	K25-26811-00	PROBE 6MM OD PTE MED NTC 2KOHM	1
9	K25-26129-02	CONNECTOR STRAIGHT PLASTIC SHORT 3/8 (.069-.187)	1
10	K25-26340-01	NUT LK CONDUIT 3/8"	1
11	K35-06605-00	LABEL PROGRAM FOR THAWING UNIT	1
12	K35-06606-00	LABEL INSTRUCTIONS FOR CLEANING UNITS	1
13	K35-06608-00	LABEL PRODUCT PLACEMENT IN ROOM	1
14	K35-06610-00	LABEL SURFACE PROBE PLACEMENT	1
15	K35-06609-00	LABEL CENTER PROBE PLACEMENT	1

OPTION SENSORS

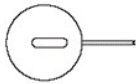

surface sensor
 \varnothing 50 x 10 mm
 p/n 6708.1454

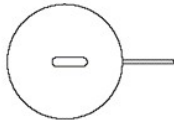

surface sensor
 \varnothing 76 x 12 mm
 p/n 6708.1458

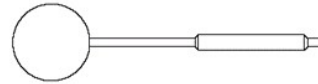

surface sensor
 \varnothing 40 x 215 mm
 p/n 6402.7002



center sensor
 \varnothing 4.5 x 35 mm
 p/n 6402.7009



center sensor
 \varnothing 4.5 x 75 mm
 p/n 6402.7010



center sensor
 \varnothing 6 x 150 mm
 p/n 6402.7001

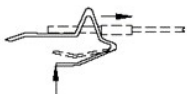

clip for \varnothing 4.5
 center sensor
 p/n 6700.2696



drill
 \varnothing 4.5 x 80
 p/n 8510.7178

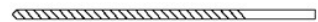

drill
 \varnothing 6 x 200
 p/n 8510.7179

9.8 TEMPERATURE CONVERSION TABLES

The number in bold-face type in the center column refers to the temperature, either in Centigrade or in Fahrenheit, which is to be converted to the other scale.

For example, converting 20°Fahrenheit to Centigrade, see 20° in the bold (center) column, the Centigrade equivalent temperature will be found in the left column, -28.9°.

TEMPERATURE			TEMPERATURE			TEMPERATURE			TEMPERATURE		
°C	°C - °F	°F	°C	°C - °F	°F	°C	°C - °F	°F	°C	°C - °F	°F
-40.0	-40	-40.0	-6.7	+20	+68.0	+26.7	+80	+176.0	+60.0	+140	+284.0
-39.4	-39	-38.2	-6.1	+21	+69.8	+27.2	+81	+177.8	+60.6	+141	+285.8
-38.9	-38	-36.4	-5.5	+22	+71.6	+27.8	+82	+179.6	+61.1	+142	+287.6
-38.3	-37	-34.6	-5.0	+23	+73.4	+28.3	+83	+181.4	+61.7	+143	+289.4
-37.8	-36	-32.8	-4.4	+24	+75.2	+28.9	+84	+183.2	+62.2	+144	+291.2
-37.2	-35	-31.0	-3.9	+25	+77.0	+29.4	+85	+185.0	+62.8	+145	+293.0
-36.7	-34	-29.2	-3.3	+26	+78.8	+30.0	+86	+186.8	+63.3	+146	+294.8
-36.1	-33	-27.4	-2.8	+27	+80.6	+30.6	+87	+188.6	+63.9	+147	+296.6
-35.6	-32	-25.6	-2.2	+28	+82.4	+31.1	+88	+190.4	+64.4	+148	+298.4
-35.0	-31	-23.8	-1.7	+29	+84.2	+31.7	+89	+192.2	+65.0	+149	+300.2
-34.4	-30	-22.0	-1.1	+30	+86.0	+32.2	+90	+194.0	+65.6	+150	+302.0
-33.9	-29	-20.2	-0.6	+31	+87.8	+32.8	+91	+195.8	+66.1	+151	+303.8
-33.3	-28	-18.4	0.0	+32	+89.6	+33.3	+92	+197.6	+66.7	+152	+305.6
-32.8	-27	-16.6	+0.6	+33	+91.4	+33.9	+93	+199.4	+67.2	+153	+307.4
-32.2	-26	-14.8	+1.1	+34	+93.2	+34.4	+94	+201.2	+67.8	+154	+309.2
-31.7	-25	-13.0	+1.7	+35	+95.0	+35.0	+95	+203.0	+68.3	+155	+311.0
-31.1	-24	-11.2	+2.2	+36	+96.8	+35.6	+96	+204.8	+68.9	+156	+312.8
-30.6	-23	-9.4	+2.8	+37	+98.6	+36.1	+97	+206.6	+69.4	+157	+314.6
-30.0	-22	-7.6	+3.3	+38	+100.4	+36.7	+98	+208.4	+70.0	+158	+316.4
-29.4	-21	-5.8	+3.9	+39	+102.2	+37.2	+99	+210.2	+70.6	+159	+318.2
-28.9	-20	-4.0	+4.4	+40	+104.0	+37.8	+100	+212.0	+71.1	+160	+320.0
-28.3	-19	-2.2	+5.0	+41	+105.8	+38.3	+101	+213.8	+71.7	+161	+321.8
-27.8	-18	-0.4	+5.5	+42	+107.6	+38.9	+102	+215.6	+72.2	+162	+323.6
-27.2	-17	+1.4	+6.1	+43	+109.4	+39.4	+103	+217.4	+72.8	+163	+325.4
-26.7	-16	+3.2	+6.7	+44	+111.2	+40.0	+104	+219.2	+73.3	+164	+327.2
-26.1	-15	+5.0	+7.2	+45	+113.0	+40.6	+105	+221.0	+73.9	+165	+329.0
-25.6	-14	+6.8	+7.8	+46	+114.8	+41.1	+106	+222.8	+74.4	+166	+330.8
-25.0	-13	+8.6	+8.3	+47	+116.6	+41.7	+107	+224.6	+75.0	+167	+332.6
-24.4	-12	+10.4	+8.9	+48	+118.4	+42.2	+108	+226.4	+75.6	+168	+334.4
-23.9	-11	+12.2	+9.4	+49	+120.2	+42.8	+109	+228.2	+76.1	+169	+336.2
-23.3	-10	+14.0	+10.0	+50	+122.0	+43.3	+110	+230.0	+76.7	+170	+338.0
-22.8	-9	+15.8	+10.6	+51	+123.8	+43.9	+111	+231.8	+77.2	+171	+339.8
-22.2	-8	+17.6	+11.1	+52	+125.6	+44.4	+112	+233.6	+77.8	+172	+341.6
-21.7	-7	+19.4	+11.7	+53	+127.4	+45.0	+113	+235.4	+78.3	+173	+343.4
-21.1	-6	+21.2	+12.2	+54	+129.2	+45.6	+114	+237.2	+78.9	+174	+345.2
-20.6	-5	+23.0	+12.8	+55	+131.0	+46.1	+115	+239.0	+79.4	+175	+347.0
-20.0	-4	+24.8	+13.3	+56	+132.8	+46.7	+116	+240.8	+80.0	+176	+348.8
-19.4	-3	+26.6	+13.9	+57	+134.6	+47.2	+117	+242.6	+80.6	+177	+350.6
-18.9	-2	+28.4	+14.4	+58	+136.4	+47.8	+118	+244.4	+81.1	+178	+352.4
-18.3	-1	+30.2	+15.0	+59	+138.2	+48.3	+119	+246.2	+81.7	+179	+354.2
-17.8	0	+32.0	+15.6	+60	+140.0	+48.9	+120	+248.0	+82.2	+180	+356.0
-17.2	+1	+33.8	+16.1	+61	+141.8	+49.4	+121	+249.8	+82.8	+181	+357.8
-16.7	+2	+35.6	+16.7	+62	+143.6	+50.0	+122	+251.6	+83.3	+182	+359.6
-16.1	+3	+37.4	+17.2	+63	+145.4	+50.6	+123	+253.4	+83.9	+183	+361.4
-15.6	+4	+39.2	+17.8	+64	+147.2	+51.1	+124	+255.2	+84.4	+184	+363.2
-15.0	+5	+41.0	+18.3	+65	+149.0	+51.7	+125	+257.0	+85.0	+185	+365.0
-14.4	+6	+42.8	+18.9	+66	+150.8	+52.2	+126	+258.8	+85.6	+186	+366.8
-13.9	+7	+44.6	+19.4	+67	+152.6	+52.8	+127	+260.6	+86.1	+187	+368.6
-13.3	+8	+46.4	+20.0	+68	+154.4	+53.3	+128	+262.4	+86.7	+188	+370.4
-12.8	+9	+48.2	+20.6	+69	+156.2	+53.9	+129	+264.2	+87.2	+189	+372.2
-12.2	+10	+50.0	+21.1	+70	+158.0	+54.4	+130	+266.0	+87.8	+190	+374.0
-11.7	+11	+51.8	+21.7	+71	+159.8	+55.0	+131	+267.8	+88.3	+191	+375.8
-11.1	+12	+53.6	+22.2	+72	+161.6	+55.6	+132	+269.6	+88.9	+192	+377.6
-10.6	+13	+55.4	+22.8	+73	+163.4	+56.1	+133	+271.4	+89.4	+193	+379.4
-10.0	+14	+57.2	+23.3	+74	+165.2	+56.7	+134	+273.2	+90.0	+194	+381.2
-9.4	+15	+59.0	+23.9	+75	+167.0	+57.2	+135	+275.0	+90.6	+195	+383.0
-8.9	+16	+60.8	+24.4	+76	+168.8	+57.8	+136	+276.8	+91.1	+196	+384.8
-8.3	+17	+62.6	+25.0	+77	+170.6	+58.3	+137	+278.6	+91.7	+197	+386.6
-7.8	+18	+64.4	+25.6	+78	+172.4	+58.9	+138	+280.4	+92.2	+198	+388.4
-7.2	+19	+66.2	+26.1	+79	+174.2	+59.4	+139	+282.2	+92.8	+199	+390.2

9.9A STANDARD CEILING

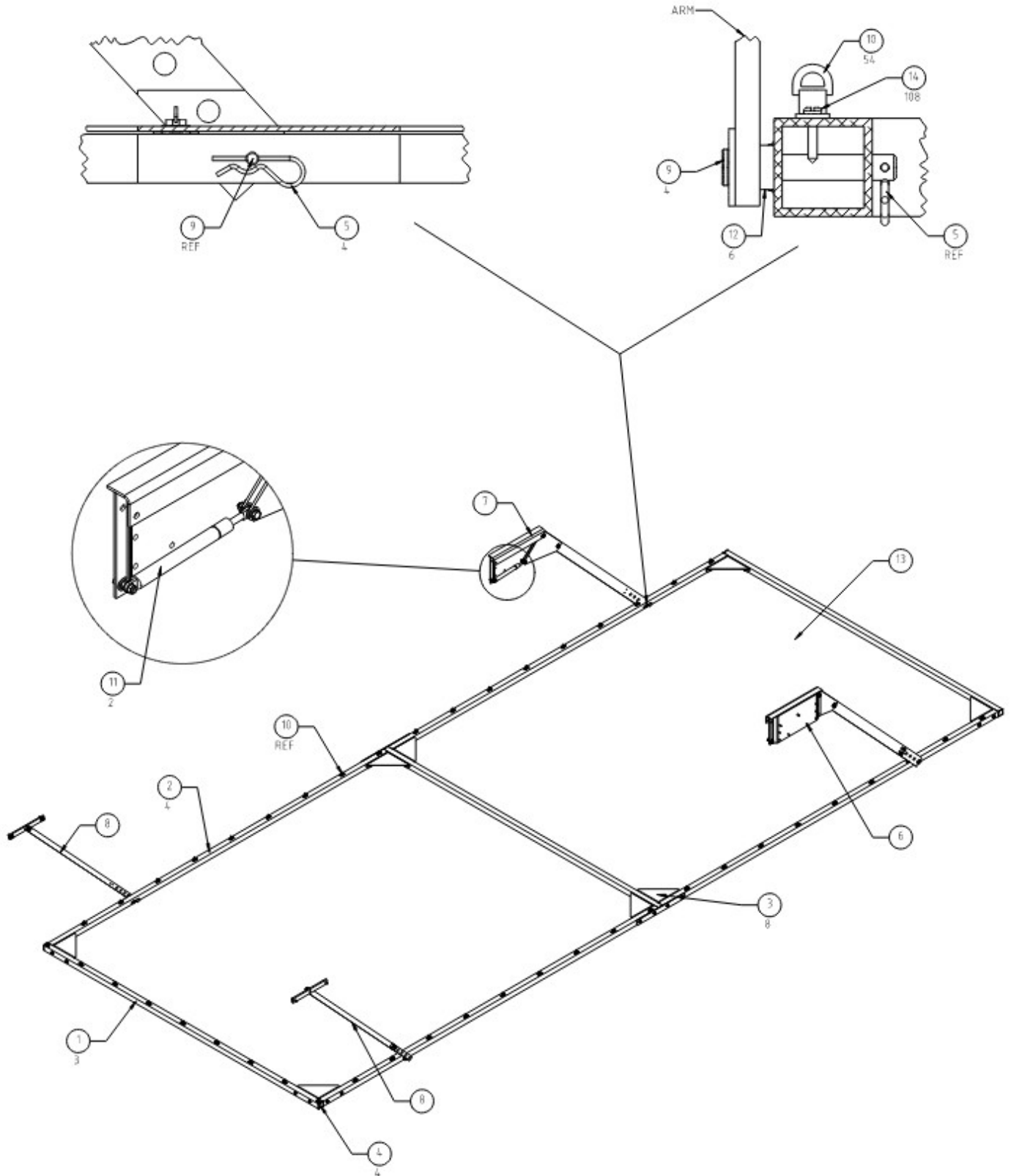

**SECTION 9.9A
STANDARD COMPOSITE ROOM CEILING**

9.9A STANDARD COMPOSITE ROOM CEILING

Kit Ceiling QTU-42, 360-16988-10 contains the following items.

ITEM	PART NO.	DESCRIPTION	QTY.
1	060-18619-05	RAIL CROSSMEMBER CEILING	3
2	060-18619-04	RAIL SIDE CEILING	4
3	060-18621-00	GUSSET CORNER CEILING	8
4	K28-11117-01	PLUG CAP END PLST FOR SQR TUBE 1.50	4
5	K21-16671-01	HAIRPIN COTTER SS 3MM X 72MM LG 304	4
6	360-18455-01	ARM CEILING UNIT END RH	1
7	360-18455-02	ARM CEILING UNIT END LH	1
8	360-18456-00	ARM CEILING DOOR END	2
9	K21-16672-05	PIN CLEVIS SS 10M DIA X 65MM LG 304	4
10	K29-18759-00	FASTENER LOCK-TWIST FOR TARPS	54
11	K29-18736-00	GAS CYLINDER TYPE 10/23 1000N	2
12	060-16094-03	PIPE PVC 3/8 SCH 80 X .59 LG	6
13	K29-18737-00	TARP POLYESTER 7800MM X 2410MM	1
14	K21-13739-00	SCREW AB PAN SS #6 X ½ LG	108

9.9B PALLET WIDE 40FT CONTAINER CEILING

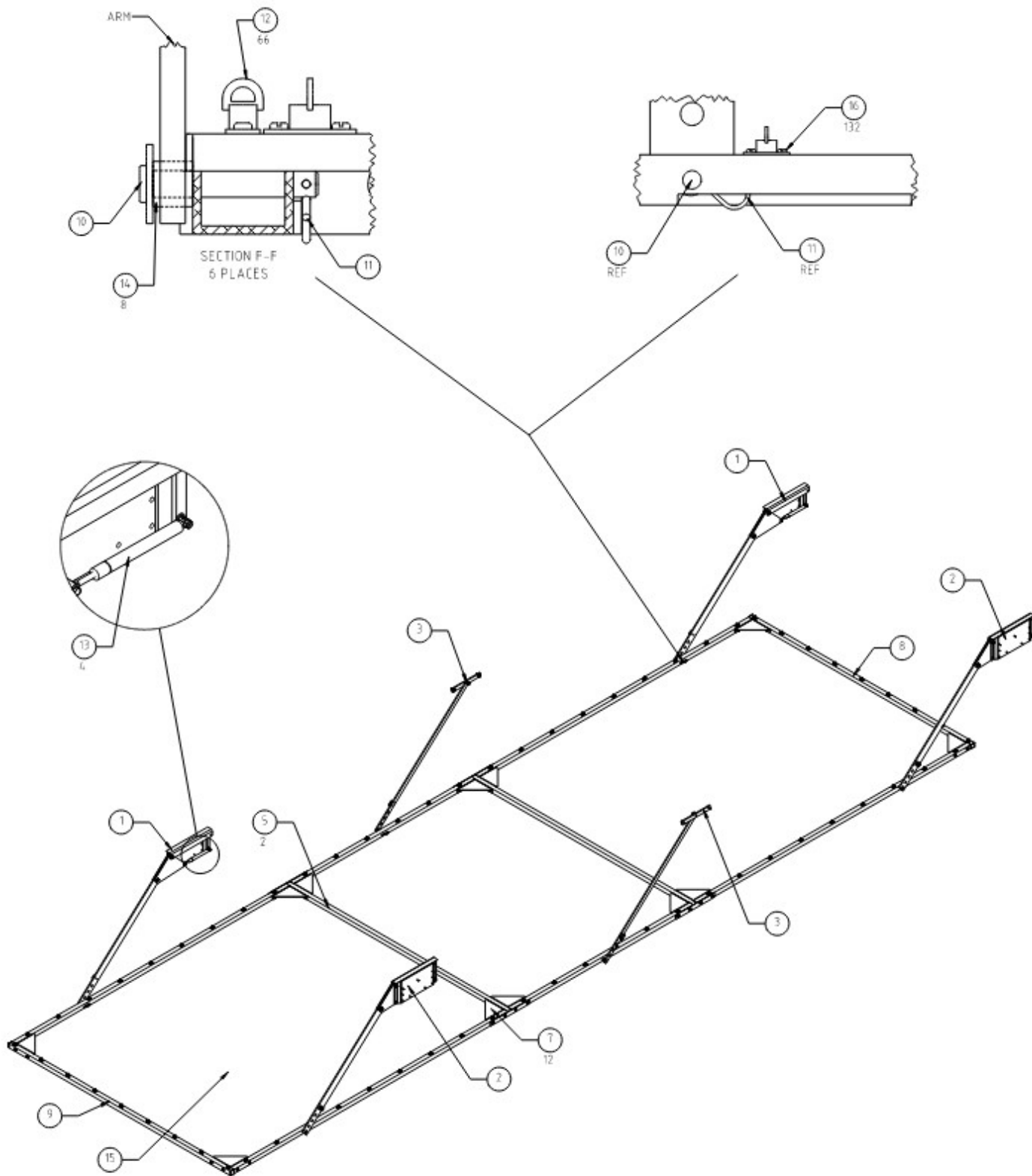

**SECTION 9.9B
PALLET WIDE 40FT CONTAINER CEILING**

9.9B PALLET WIDE 40FT CONTAINER CEILING

Kit Ceiling QTU Pallet Wide 40 FT, 360-18618-00 contains the following items.

ITEM	PART NO.	DESCRIPTION	QTY.
1	360-18455-03	ARM CEILING UNIT END RH	2
2	360-18455-04	ARM CEILING UNIT END LH	2
3	360-18456-00	ARM CEILING DOOR END	2
4	360-18620-01	RAIL SIDE CENTER WITH FASTENERS	2
5	060-18619-03	RAIL CROSSMEMBER CEILING	2
6	360-18620-00	RAIL SIDE END CEILING WITH FASTENERS	4
7	060-18621-00	GUSSET CORNER CEILING	12
8	360-18619-00	RAIL DOOR END CROSSMEMBER CEILING W/ FASTENERS	1
9	360-18619-01	RAIL UNIT END CROSSMEMBER CEILING	1
10	K21-16672-05	PIN CLEVIS SS 10M DIA X 65MM LG 304	6
11	K21-16671-01	HAIRPIN COTTER SS 3MM X 72MM LG 304	6
12	K29-18759-00	FASTENER LOCK-TWIST FOR TARPS	57
13	K29-18736-01	GAS CYLINDER ST-1 150 STROKE 750N	4
14	060-16094-03	PIPE PVC 3/8 SCH 80 X .59 LG	8
15	K29-18737-02	TARP POLYESTER 385IN X 93.5IN	1
16	K21-13739-00	SCREW AB PAN SS #6 X ½ LG	132

9.9C STANDARD 40FT CONTAINER CEILING

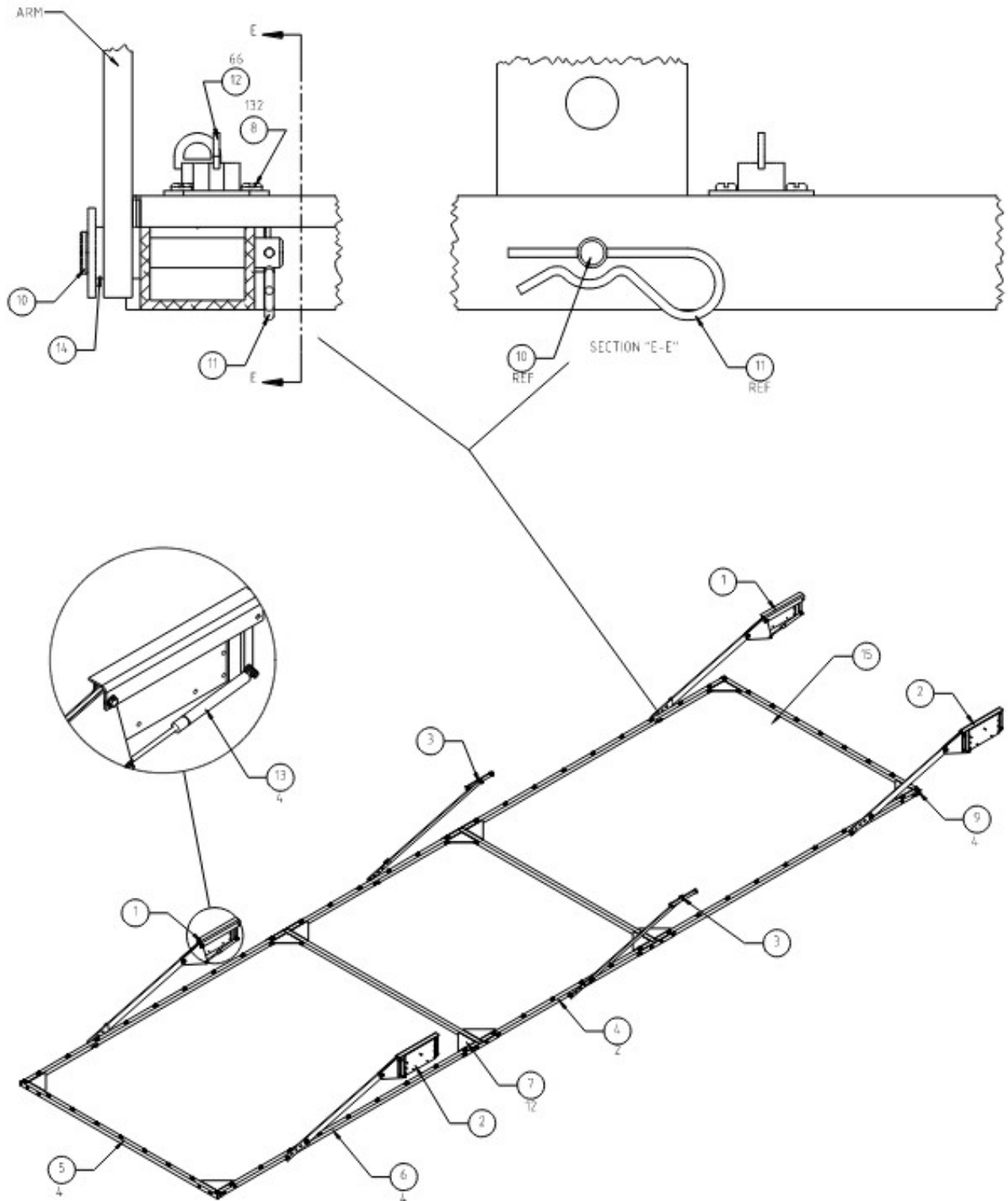

**SECTION 9.9C
BUTCHER DOOR AND ROLL-UP DOOR 40FT CONTAINER CEILING**

9.9C STANDARD 40FT CONTAINER CEILING

Kit Ceiling QTU Butcher Door 40 FT, 360-18618-01 contains the following items.

Kit Ceiling QTU Roll-Up Door 40 FT, 360-18618-02 contains the following items.

ITEM	PART NO.	DESCRIPTION	QTY.
1	360-18455-03	ARM CEILING UNIT END RH	2
2	360-18455-04	ARM CEILING UNIT END LH	2
3	360-18456-00	ARM CEILING DOOR END	2
4	360-18620-01	RAIL SIDE CENTER WITH FASTENERS	2
5	060-18619-13	RAIL CROSSMEMBER CEILING	4
6	360-18620-00	RAIL SIDE END CEILING WITH FASTENERS	4
7	060-18621-00	GUSSET CORNER CEILING	12
8	K21-13739-00	SCREW AB PAN SS #6 X ½ LG	132
9	K28-11117-01	PLUG CAP END	4
10	K21-16672-05	PIN CLEVIS SS 10M DIA X 65MM LG 304	6
11	K21-16671-01	HAIRPIN COTTER SS 3MM X 72MM LG 304	6
12	K29-18759-00	FASTENER LOCK-TWIST FOR TARPS	66
13	K29-18736-01	GAS CYLINDER ST-1 150 STROKE 750N	4
14	060-16094-03	PIPE PVC 3/8 SCH 80 X .59 LG	8
15	K29-18737-05	TARP POLYESTER 385IN X 87.5IN	1