

KLINGE



MODEL NMF-372-02 OPERATION, SERVICE AND PARTS MANUAL



Address: 4075 East Market Street York, PA 17402-5100 USA
Telephone: 717-840-4500 Telefax: 717-840-4501
www.klingecorp.com

MANUFACTURED BY KLINGE CORPORATION

Service Request

Requests for Service should be directed to the Klinge Service Team. The below link should be used to place all requests for service and will afford the quickest response time.

<https://klingecorp.com/request-service/>

This form will help us determine model and age of the equipment, location, basic details about the issue, who to contact and how to best handle the issues with the equipment. A service ticket number will be provided in a response email once the form is received and processed. If the equipment is out of warranty, charges may apply for extensive technical support.

Additionally, our Service Department can be reached via email at technical@klingecorp.com.

Spare Parts Request

Requests for Spare Parts should be directed to our Parts Department via email at spares@klingecorp.com. Please have available at the time of the request the Serial Number of the equipment to ensure that the proper part is provided.

Use of this Manual

The use of this manual is intended for the safe operation of the equipment described. It is therefore reasoned that persons who have the occasion to use this manual have a knowledge of mechanical and electrical systems and components addressed by its' contents. However, efforts have been made to enable persons less familiar with these systems to use this manual.

The equipment may be installed in a number of configurations. Each may have optional items and differing external details provided by third parties. The specific electrical circuit and pipe diagram are posted on the unit as decals.

Most external and internal pipework parts are standard commercially available pipe fittings and not covered here. For external pipe fitting, replace like for like, taking care to replace stainless steel with stainless steel.

Suggestions as to improvement in content and format are welcome and should be addressed to engineering@klingecorp.com. Corrections and improvements will be included on dated revisions – the latest of which will be available upon request.

TABLE OF CONTENTS

SECTION 1. GENERAL DESCRIPTION	6
SECTION 2. REFRIGERATION SYSTEM	7
2.1 REFRIGERANT R134a High temperature system, compressors 1 & 2	7
2.2 REFRIGERANT R23 Low temperature system, compressor 3	7
2.3 UNIT PIPING DIAGRAM	9
SECTION 3. OPERATION	10
3.1 GENERAL INFORMATION	10
3.2 PRE-STARTING	10
3.3 STARTING CHECK	10
3.4 RUNNING UNIT	11
3.5 VACUUM VALVE	12
SECTION 4, ELECTRICAL AND ELECTRONIC FUNCTION	13
4.1 GENERAL INFORMATION	13
4.2 ELECTRIC BOX	13
4.3 DISPLAY	14
4.4 ELECTRICAL DIAGRAMS	15
SECTION 5. CONTROLLER INSTRUCTIONS AND SEQUENCE	18
5.1 GENERAL INFORMATION	18
5.2 CONTROLLER	18
5.3 DISPLAY	21
5.4 KEYPAD	23
5.5 NMF-372 Cargo Alarm Functionality	25
5.6 TEMPERATURE SENSOR NTC (ONLY AMBIENT SENSOR)	27
5.7 TEMPERATURE SENSOR PT1000	28
5.8 TEMPERATURE CONVERSION TABLES	29
SECTION 6. MAINTENANCE AND SERVICE INSTRUCTION	30
6.1 SAFETY	30
6.2 CHECK REFRIGERANT R134a CHARGE	30
6.3 CHECK REFRIGERANT R23 CHARGE	31
6.4 PROCEDURE FOR ADDING REFRIGERANT R134a	31
6.5 PROCEDURE FOR ADDING REFRIGERANT R23	32
6.7 OPENING R134a SYSTEM	32
6.8 OPENING R23 SYSTEM	32
6.9 TESTING FOR LEAKS	32
6.10 VACUUM THE SYSTEM	33
6.11 REFRIGERANT R134a /R23, TEMPERATURE / PRESSURE TABLE	34
SECTION 7. SERVICING COMPONENTS	35
7.1 COMPRESSOR (R134a / R23)	35
7.2 COND. AND EVAP. FANS MOTOR	36
7.3 COND. AND EVAP. FANS	36
7.4 FILTER-DRIER ASSEMBLY	36
7.5 HIGH-PRESSURE SWITCH, COMPRESSOR	37
7.6 PRESSURE TRANSDUCERS	37
7.7 THERMAL EXPANSION VALVE	37
7.8 SAFETY RELIEF VALVE	38
7.9 NON-RETURN VALVE	38
7.10 CRANKCASE PRESSURE REGULATOR, R23	38
7.11 LIQUID INJECTION VALVE, COMPRESSORS R134a	38
7.12 LIQUID INJECTION VALVE, COMPRESSOR R23	39
7.13 MAX. HOT GAS PRESSURE REGULATOR	39
7.14 LIQUID SOLENOID VALVE, R134a	39
7.15 HOT GAS SOLENOID VALVE	39
7.16 HEATED VACUUM VALVE	39
7.17 SERVICING SCHEDULE	40
SECTION 8. TROUBLE SHOOTING	41

8.1 GENERAL INFORMATION	41
8.2 ALARM CHART.....	41
8.3 UNIT INFORMATION	44
SECTION 9. SERVICE PARTS	45
SECTION 9.1 UNIT FRONT	47
SECTION 9.2A CONDENSER SECTION LH (R134a Compressor side 2 per system)	49
SECTION 9.2B CONDENSER SECTION RH (R23 Compressor side 2 per system).....	51
SECTION 9.2C CONDENSER SECTION RH (R23 Compressor side 2 per system).....	53
SECTION 9.3A EVAPORATOR SECTION (fan and probes 2 per system)	55
SECTION 9.3B EVAPORATOR SECTION (piping 2 per system).....	57
SECTION 9.4 ELECTRICAL BOX UNIT 1 (Top).....	59
SECTION 9.5 ELECTRICAL BOX UNIT 2 (BOTTOM)	61
SECTION 9.6A CHANGEOVER BOX (Outside).....	63
SECTION 9.6B CHANGEOVER BOX (Inside).....	65
SECTION 9.7 MPC3 DISPLAY.....	67
SECTION 9.8A KIT SPARE PARTS (OPTIONAL) (Outside).....	69
SECTION 9.8B KIT SPARE PARTS (OPTIONAL) (Inside).....	71
SECTION 9.8C BOX SPARE PARTS MISC (OPTIONAL).....	73

SECTION 1. GENERAL DESCRIPTION

The **NMF-372-02** system (**N**ose **M**ounted **F**reezer) is a redundant system based on the use of two Klinge NMF-371 freezer units. Each NMF-371 is designed especially for mounting and handling of cargo in customer built-in rooms or to be mounted on standard insulated containers. The unit maintains cargo in the temperature range from -20°C to -70°C.

The system operates in ambient temperature up to +50°C.

The system is designed to maintain temperatures in the container by use of automatic cooling and defrost cycles. Operation requires 50Hz: 360VAC min – 460VAC max, 60Hz: 400VAC min – 500VAC max, three phase, electrical power.

Control circuit power is reduced to 24/28VAC

Each NMF-371's refrigeration unit builds up as cascade systems (two systems with common heat exchanger), one high temperature system, (compressors 1 & 2, R134a) and one low temperature system (compressor 3, R23). (See section 2)

Controls for both system 1 and system 2 are integrated into a single control box. Temperature setting and monitoring of either system is available using the systems' controllers.

The system is controlled by a microprocessor controller (MPC3). The MPC3 software will choose which system will operate as the primary system. Only one system will operate at a time.

The electrical system consists of all necessary circuit breakers, relays, and controls for automatic operation of all functions (temperature control, defrosting, etc.).

A phase sequence sensor and reversing contactor are installed to ensure correct rotation of compressors, regardless of incoming phase sequence.

Each system has an electronic microprocessor controller to control the temperature in the box/container, when that system is operating.

The defrost cycle can be activated 3 ways:

1. Start on timer.
2. Demand defrost.
3. Manual defrost.

(See Section 3.4)

The defrost cycle terminates automatically when the temperature of the defrost sensor rises to the pre-set limit (can be set from +5° to +30°C). When the defrost cycle terminates, the controller will cause a changeover to the secondary system, making this the primary system, for even run time for the compressors.

The defrost operates on hot gas from compressor 3.

The unit can be delivered as a complete assembled unit, complete with full charge of refrigerant, compressor oil, factory tested and ready for operation after installation.

OPTION

For operating on 200/230volt, 50/60Hz, a dual voltage transformer can be supplied.

SECTION 2. REFRIGERATION SYSTEM

2.1 REFRIGERANT R134a High temperature system, compressors 1 & 2

R134a has ozone depletion potential (ODP) of zero.
When using R134a, the compressor oil must be ester synthetic oil.

A moisture indicator is installed in the liquid line immediately after the filter drier to indicate if there is moisture in the refrigerant charge.

The element, which is in the center of the indicator, will change color on contact with moisture in the refrigerant passing over it.

A dry system will be indicated by a dark green color; a wet system will show from a yellowish green to bright yellow, depending on the amount of moisture in the system. A colored leak-detecting agent, added to the refrigerant, will permanently discolor the indicator, and should therefore not be used. It will also become discolored if a compressor motor burn-out occurs and should be replaced after clean-out.

The following is a brief explanation of a few of the components in the system and their functions:

- The condenser fans move air across the condenser coil surface for the purpose of removing heat.
- The purpose of the heat exchanger (134a/R23) is to remove heat from the low temperature system.
- The purpose of the compressor is to provide a high temperature, high-pressure vapor to the condenser coil so that heat can be removed with the ambient temperature air. At the same time this causes a pressure differential between parts of the system and creates a flow pattern.
- The expansion valve is a device, which provides liquid to the heat exchanger as required.

It is important to remember the parts of the system that are subject to high-pressure and low-pressure refrigerant. The high pressures will be accompanied by high temperatures, and the low pressures will be accompanied by low temperatures.

The common terminology used for these parts of the system is "the high side" and "the low side". The area from the discharge side of the compressor to the inlet side of the expansion valve is referred to as the high side. The area from the outlet side of the expansion valve to the suction side of the compressors is referred to as the low side.

2.2 REFRIGERANT R23 Low temperature system, compressor 3

R23 has ozone depletion potential (ODP) of zero.
When using R23, the compressor oil must be ester synthetic oil.

A moisture indicator is installed in the liquid line immediately after the heat exchanger to indicate if there is moisture in the refrigerant charge.

The element, which is in the center of the indicator, will change color on contact with moisture in the refrigerant passing over it.

A dry system will be indicated by a dark blue color; a wet system will show orange. A purple color indicates caution. A colored leak-detecting agent, added to the refrigerant, will permanently discolor the indicator, and should therefore not be used. It will also become discolored if a compressor motor burn-out occurs and should be replaced after clean-out.

The following is a brief explanation of a few of the components in the system and their functions:

- The purpose of the heat exchanger is to move heat from the low temperature system to the refrigerant in the "high temperature system"
- The evaporator fans move air across the evaporator coil for the purpose of removing heat from cargo.

- The purpose of the compressor is to provide a high temperature, high-pressure vapor to the condenser coil so that heat can be removed with the heat exchanger surface (evaporator comp. 1 & 2, condenser comp.3). At the same time this causes a pressure differential between parts of the system and creates a flow pattern.
- The expansion valve is a device, which provides liquid to the evaporator coil as required.

It is important to remember the parts of the system that are subject to high-pressure and low-pressure refrigerant. The high pressures will be accompanied by high temperatures, and the low pressures will be accompanied by low temperatures.

The common terminology used for these parts of the system is "the high side" and "the low side". The area from the discharge side of the compressor to the inlet side of the expansion valve is referred to as the high side. The area from the outlet side of the expansion valve to the suction side of the compressor is referred to as the low side.

SECTION 3. OPERATION

3.1 GENERAL INFORMATION

DO NOT REMOVE ANY COVER PLATE TO ROTATING PARTS BEFORE TURNING OFF POWER AND DISCONNECTING THE POWER PLUG.

To understand the operation of the electrical and refrigeration systems on the NMF-372-02 unit, there are several things which must be remembered:

1. The NMF-372-02 is made up of two independent systems. Only one system will operate at any time, however, both systems need to be switched "ON" to ensure automatic changeover.
2. The electrical section consists of two complete electrical systems, one for each system.
3. The electronic microprocessor thermostats control the temperature of the cargo space. Each system has its own thermostat.
4. The main electrical operating power is 400/460volt +/-10%, 3 phase, 50/60Hz+/-2.5%.
5. The unit's refrigeration systems are build up cascade systems (two systems with common heat exchanger). One "high temperature system" (Compressor 1 & 2, R134a.) and one "low temperature system" (Compressor 3, R23.)
6. When the power is switched "ON", the unit will start up with different delay timer functions from the microprocessor controller.
(See section Five.)
7. Both systems must be turned "ON", with matching set points for proper operation.
8. Each system has two circuit breakers protecting the electric system. One protects the main line 400/460volts 3 phase power, and the other protects the 24/28volts control circuit.
9. The high-pressure switches are in the port / pipe of each compressor respectively and are reset automatically.
10. All compressors are protected with overheat sensor controls by the microprocessor controller.

3.2 PRE-STARTING

NOTE: The NMF-372-02 Pre-Trip Inspection (PTI) form can be found on Klinge's website at:
<http://www.klingecorp.com/pti/>

The following inspections should be made as part of a pre-trip inspection before the container is loaded:

- Check the unit visually for physical damage.
- Check major hold-down bolts etc. visually.
- Check that the control boxes are properly secured in their locked positions.
- Open the control box cover and check that all electrical components are secured and that the terminal connections are tight.
- Check the gasket on the control box cover and that the draw latches will hold the cover tightly closed.
- Check the cleanliness of the condenser coils and clean if necessary.
- Check all the refrigerant joints and connections thoroughly for traces of oil, which could be caused by a small refrigerant leak.

3.3 STARTING CHECK

1. Connect the main power plug with the receptacle to supply power to unit.
2. Ensure each unit's CB circuit breakers, in the electrical boxes are closed in the "ON" position.
3. Switch the system's ON/OFF switch to "ON".
(Timer delay for start.)
4. As soon as the unit starts, scroll down in the Display menu to see the high and low-pressure in the refrigerant system. Check the pressure in the R23 system, if the pressure is 14 to 19 bar the unit is fully functional with R23 refrigerant.

Quick function, to see Pressure:



(Display shows low and high-pressure for R23/134a.)

Quick function, to see temperature:



(Display shows temperature for refrigerant R23/134a.)

5. Adjust set point to be lower than box temperature, can be set from -20° to -70°C.
6. Check defrost interval (set under "config" in display), can be set from 3 to 99 hours, factory setting is 24 hours.
7. Check defrost termination temperature (set under "config" in display), can be set from 5° to 30°C., factory setting is 18°C.
8. Check log (data logger) interval (set under "config" in display), can be set from 6 to 60 min., factory setting is 15 min.
9. Start "Run auto test" (start in "commands" in display), the unit will run the auto test for checking amps on all motors and goes to normal operation after test.
See Sec 5.2 Controller for info about auto test
(If some of the motors failed, see event log.)
10. Check difference between "Return Air" RT and "Supply Air" SU temperature sensors in display, should be between 3 to 7°C.
11. Check refrigerant level on "high temperature system" (R134a) in the sight glass after approx. 15 minutes of continuous running.
12. After starting check, adjust set point to box loading temperature.
13. Turn the ON/OFF switch to "OFF".
14. Repeat steps 4 through 14 for the second system.
15. After the second unit has completed the starting check, switch the other system to "ON" and allow the unit to operate.

3.4 RUNNING UNIT

Having been started, and with the temperature set to the desired setting, the unit will now be controlled by the controller to reach the set-point temperature.

If an alarm occurs on the primary system, the backup system will be activated to maintain cargo temperature.

COOLING CYCLES

When the cargo temperature requires maximum cooling, the compressors and evaporator fan will run, and the condenser fan will operate to draw air over the air-cooled condenser coil. The cargo temperature will continue to pull down until it reaches set-point; the compressors and the condenser fan motor will stop. The controller regulates via the "RETURN AIR SENSOR" mounted in the return air from the container.

DEFROST CYCLES

The defrost cycle can be activated manually, or automatically by the controller.

The defrost can be activated in 3 different ways:

1. Manual defrost, starts from the display panel.
2. Start on timer. (can be set from 3 to 99 compressor run hours) (set under "config" in display), factory setting is 24 hours.
3. Starts on Demand defrost.
When unit is started, the first timer defrosting will begin after ¼ of the timer setting (timer set = 24 compressor run hours, first defrost = 6 hours), or first time the return air temperature goes below -29°C (whichever comes first).

If the unit has been disconnected from power for more than one hour. the timer setting will be reset.

The unit will also start a defrost, if the supply air sensor is more than 10°C lower than the return air sensor; or if the defrost sensor is more than 15°C lower than the return air sensor.

The defrosting of the coil and drain pan operates on hot gas from compressor 3. The condenser fan and the evaporator fans are stopped during defrosting.

Termination of the defrost is automatic, when the temperature of the defrost sensor (evap. temp.) rises to the pre-set limit (can be set under "config" in display, from +5° to +30°C), factory setting is 18°C.

If the defrost is not complete in maximum defrost operating time, the controller will restart the unit secondary system, making it now the primary system. The max. defrost operating time can be set under "config" in display, from 15 to 99 minutes. Factory max. defrost time is set to 45 min.

NOTE: After the system power has been turned ON, an "initial" defrost cycle is activated after ¼ of the timer setting identified in #2 above.

For example: in #2 above the timer factory setting is 24 compressor run hours, so an "initial" defrost cycle is activated 6 hours after a system is powered ON.

If the timer setting is changed to 48 compressor run hours, an "initial" defrost cycle would occur 12 hours after the system is powered ON.

3.5 VACUUM VALVE

The vacuum valve draws outside air into the container to prevent the container from developing negative atmospheric pressure as the cargo temperature decreases toward -70°C. This is activated during pulldown as well as when there is a quick temperature change within the container for example during a Door Opening or Defrost Operation.

It is extremely important to check the vacuum pipe opening, to make sure that the pipe is not blocked by ice or snow. The frequency of this check is dependent on the operation conditions of the unit. We suggest that this check should be performed on a weekly basis and possibly more frequently if there are a number of Door Openings.

SECTION 4, ELECTRICAL AND ELECTRONIC FUNCTION

4.1 GENERAL INFORMATION

When high voltage is being fed to the unit and CB 1 is in the ON position, the power will pass along L1, L2 and L3 to the line of the: compressor relay (CMR1-CMR2-CMR3), condenser fan relay (CFR), evaporator fan relays (EFR) and the transformer.

Note:

Beware of high voltage (400/460volt) in various parts of the unit, it is recommended that a thorough study of the wiring diagram be made to determine where high voltage may be encountered when power is fed to the unit.

When the unit ON/OFF switch is placed in the ON position, the POWER ON light is lit.

PHASE SELECTION

The 28volt AC power from the transformer will pass along wires no. 01 and X2 through the circuit breaker CB 2, and continue in wires no. 02 and X2 to the control power. The 24volt power from the transformer will pass along wires no. 03 and 04 through the controller logic.

All wires are numbered on both ends.

4.2 ELECTRIC BOX

CIRCUIT BREAKER

- A. Circuit Breaker. (CB1).
The 32-amp circuit breaker incorporates three breakers, one for each line. It is reset manually and protects the entire unit against overload.
The circuit breaker is adjusted to 32 amps and must be manually reset when tripped.
- B. Circuit Breaker. (CB2).
The 5-amp circuit breaker protects the 28volt control power in case of possible overload. The circuit breaker must be manually reset when tripped.

RELAYS

- A. Compressor 1, motor relay. (CMR1)
3 poles, 460volts, and direct-in-line contactor with 28volt AC operating coil. It operates compressor 1 motor and is energized by the controller.
- B. Compressor 2, motor relay. (CMR2)
3 poles, 460volts, and direct-in-line contactor with 28volt AC operating coil. It operates compressor 2 motor and is energized by the controller.
- C. Compressor 3 motor relay. (CMR3)
3 poles, 460volts, and direct-in-line contactor with 28volt AC operating coil. It operates compressor 3 motor and is energized by the controller.
- D. Condenser fan motor relay. (CFR)
3 poles, 460volts, and direct-in-line contactor with 28volt AC operating coil. It operates condenser fan 1 motor (bottom fan) and is energized by the controller.
- E. Evaporator fan motor relay. (EFR)
3 poles, 460volts, and direct-in-line contactor with 28volt AC operating coil. It operates the evaporator fan motors and is energized by the controller.
- F. Phase sensor relay. (PCR1 / PCR2)
3 poles, 460volts, and direct-in-line contactor with 28volt operating coil. It operates the change in rotation of motors in the unit and is energized by the controller. Between the two relays a safety mechanical lock device is mounted to prevent that both relays can be energized at the same time.

TRANSFORMER (TR)

The primary windings are tied into the line from circuit breaker CB1. The secondary windings supply 28 volts for the main control power, and 24 volts for the controller logic.

CURRENT TRANSFORMER (CT)

For correcting rotation of fans/compressor in the unit (phase direction) and for showing the actual current of the unit load in the display, the unit has installed one 3 phase current transformer (see under "unit data" in display).

BATTERY PACK (BATT)

To supply power to the controller, if the unit is disconnected from the main power, a 6volt rechargeable (Ni-MH) battery pack, is installed in the system.

PROGRAM CODE RESISTOR (PCR)

The microprocessor controller has a software program that can be used for multiple units. To indicate that the controller is used for the NMF-372-02 unit, the controller has a pre-set code for each system, loaded in the config menu.

The controller also has a resistor code installed (pin 6-8, 10-pole plug).

The resistor codes for the NMF-372-02 are: System 1 – 2200 Ω , System 2 – 2400 Ω .

If the resistor code fails, disconnect the resistor code, and manually set the program code in the display, under "Control setting - System no." to system No. 26 for System 1 and No. 27 for System 2.

Note: Without a resistor code installed, the MPC3 controller will not automatically select the right program if you restore a new controller on the unit.

CONTROLLER (MPC3 software version min. #065)

The microprocessor controller is based on the newest technology, and not only controls operation of the unit, but also collects temperature data for the data logger and data for event logging.

- A. Controller, 16 relay output and 16 analog input, battery back-up for setting of set point without starting the unit, and seven sensors for measuring of unit data information.
- B. Data logging, log interval can be set from 6 to 60 min., set to 6 min. the data logger will contain data for approximately 30 days, set to 60 min. approximately 300 days.
When the data logger reaches maximum capacity, new data will overwrite the oldest data.
- C. Event logging, log contains all information of the last 2000 events. (Main power on/off --defrost start/end--set-point change--alarm etc. See under data logger in display)

4.3 DISPLAY

LIGHT

- A. Power on. (Green.)
An LED light indicates that power is on.
- B. Alarm on. (Red.)
An LED light indicates if there is any alarm coming from the controller. (See alarm information in display and troubleshooting Section 8.)

DISPLAY

The display shows all information regarding temperature on all unit sensors, all data logged in data logger and all information for unit operating conditions.

KEYPAD

The four keypad buttons are for setting temperature and scrolling through unit data information.

4.4 ELECTRICAL DIAGRAMS

Unit 1

MAIN POWER.

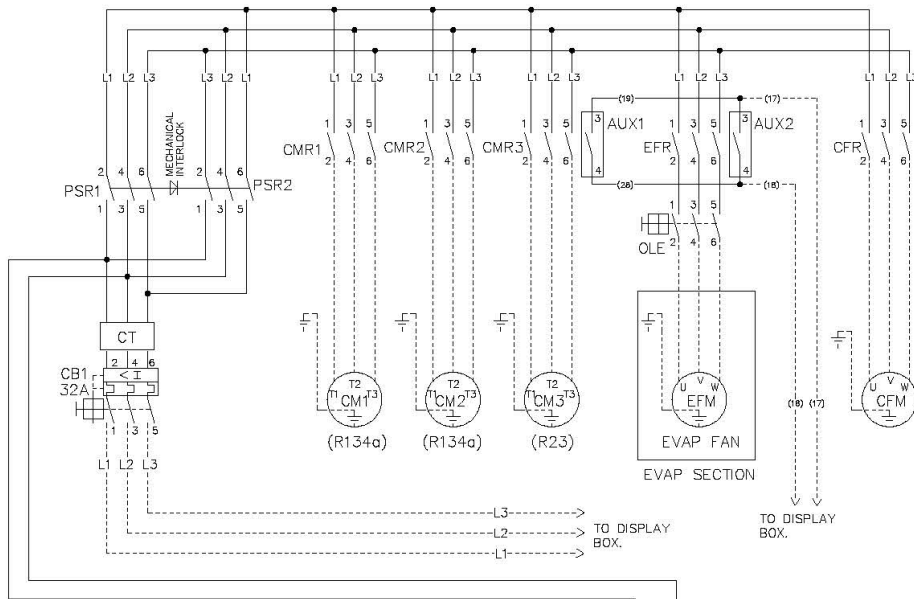

- CB1 = CIRCUIT BREAKER 32A
- CB2 = CONTROL RESET CIRCUIT BREAKER 8A
- CFM = CONDENSER FAN MOTOR
- CFR = CONDENSER FAN RELAY
- CM1 = COMPRESSOR MOTOR 1
- CM2 = COMPRESSOR MOTOR 2
- CM3 = COMPRESSOR MOTOR 3
- CMR1 = COMPRESSOR MOTOR 1 RELAY
- CMR2 = COMPRESSOR MOTOR 2 RELAY
- CMR3/AUX1 = COMPRESSOR MOTOR 3 RELAY & AUX 1
- CT = CURRENT TRANSFORMER
- EFM = EVAPORATOR FAN MOTOR
- EFR/AUX2 = EVAPORATOR FAN RELAY & AUX 2
- HG = HOT GAS SOLENOID VALVE
- HP1 = COMP.1 & 2 HIGH PRESSURE SWITCH
- HP2 = COMP.3 HIGH PRESSURE SWITCH
- LSV = LIQUID SOLENOID VALVE(R134a)
- MLC = MAX LOAD CONTROL
- OLE = OVERLOAD EVAP FAN MOTOR
- ON = POWER ON LAMP
- PSR1 = PHASE SENSOR RELAY 1
- PSR2 = PHASE SENSOR RELAY 2
- TR1 = TRANSFORMER UNIT BOX
- = WIRING INSIDE ELECTRICAL BOX
- - - = WIRING OUTSIDE ELECTRICAL BOX
- ⊙ = TERMINAL ACCESS POINT

CONTROL POWER.

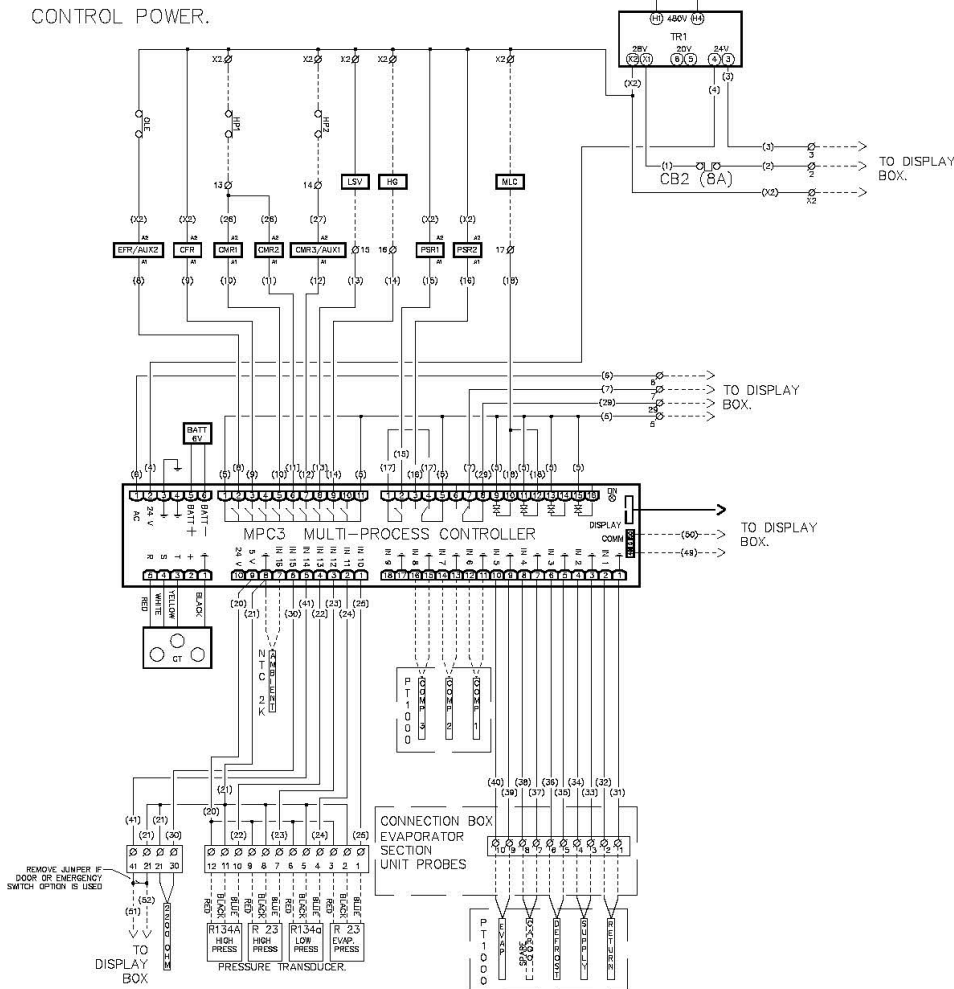

ELECTRICAL DIAGRAM NMF-372 UNIT 1

Unit 2

MAIN POWER.

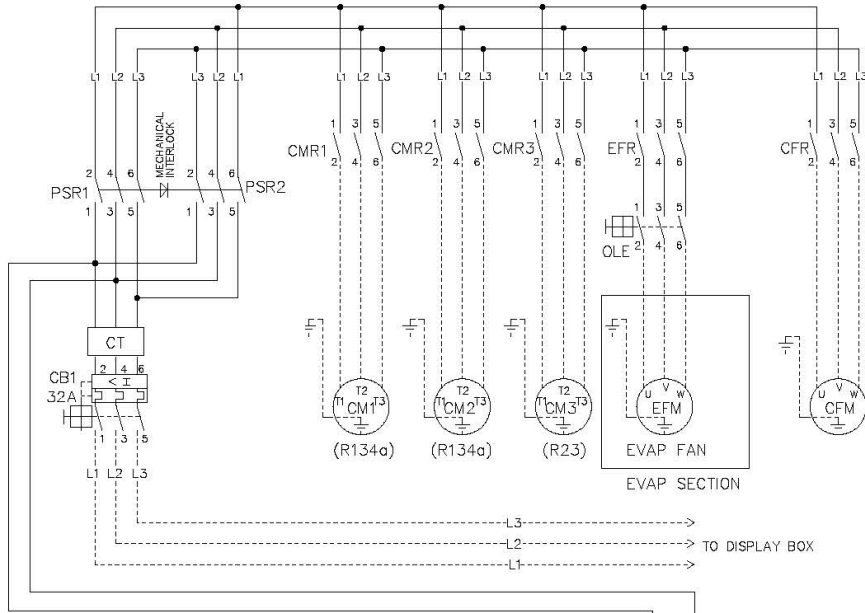

- CB1 = CIRCUIT BREAKER 32A
- CB2 = CONTROL RESET CIRCUIT BREAKER 8A
- CFM = CONDENSER FAN MOTOR
- CFR = CONDENSER FAN RELAY
- CM1 = COMPRESSOR MOTOR 1
- CM2 = COMPRESSOR MOTOR 2
- CM3 = COMPRESSOR MOTOR 3
- CMR1 = COMPRESSOR MOTOR 1 RELAY (R134a)
- CMR2 = COMPRESSOR MOTOR 2 RELAY (R134a)
- CMR3 = COMPRESSOR MOTOR 3 RELAY (R23)
- CT = CURRENT TRANSFORMER
- EFM = EVAPORATOR FAN MOTOR
- EFR = EVAPORATOR FAN RELAY
- HG = HOT GAS SOLENOID VALVE
- HP1 = COMP.1 & 2 HIGH PRESSURE SWITCH
- HP2 = COMP.3 HIGH PRESSURE SWITCH
- LSV = LIQUID SOLENOID VALVE(R134a)
- MLC = MAX LOAD CONTROL
- OLE = OVERLOAD EVAP FAN MOTOR
- ON = POWER ON LAMP
- PSR1 = PHASE SENSOR RELAY 1
- PSR2 = PHASE SENSOR RELAY 2
- TR = TRANSFORMER
- = WIRING INSIDE ELECTRICAL BOX
- - - = WIRING OUTSIDE ELECTRICAL BOX
- ⊗ = TERMINAL ACCESS POINT

CONTROL POWER.

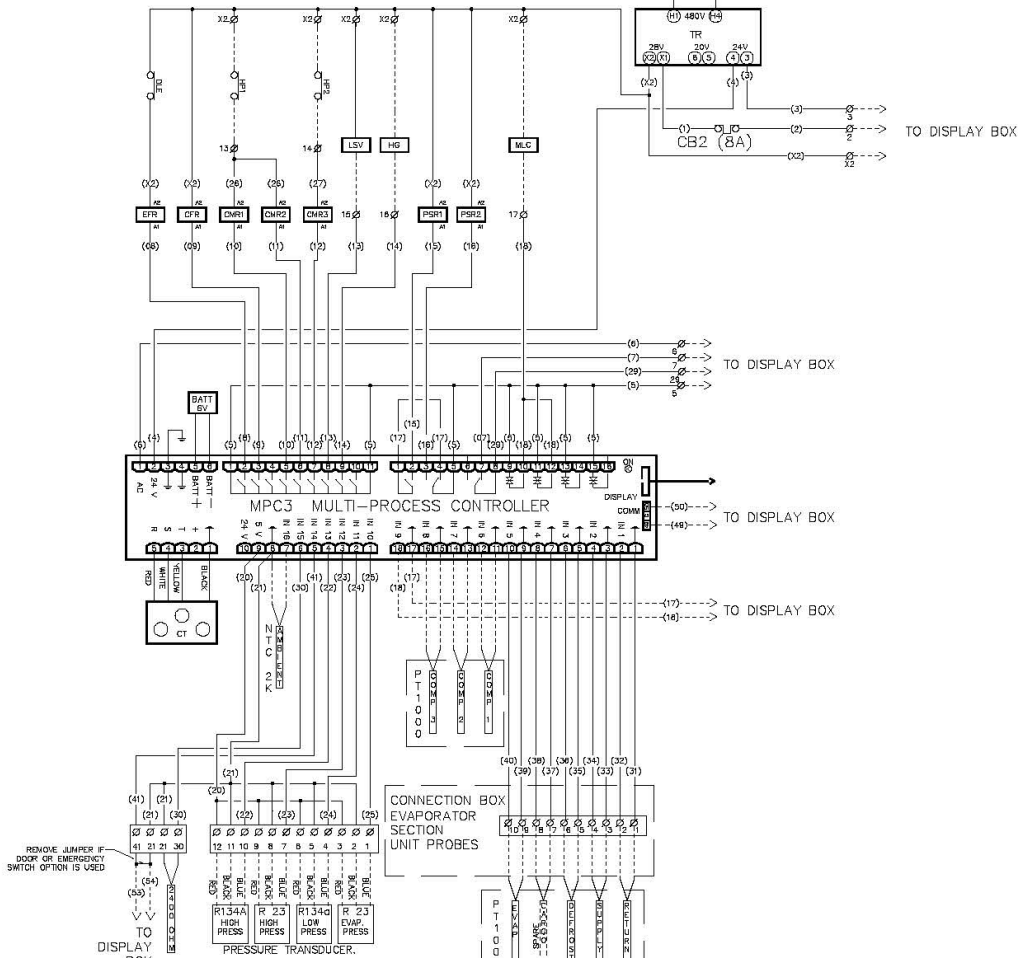

ELECTRICAL DIAGRAM NMF-372 UNIT 2

K35-06629-04 REV E

Changeover Box

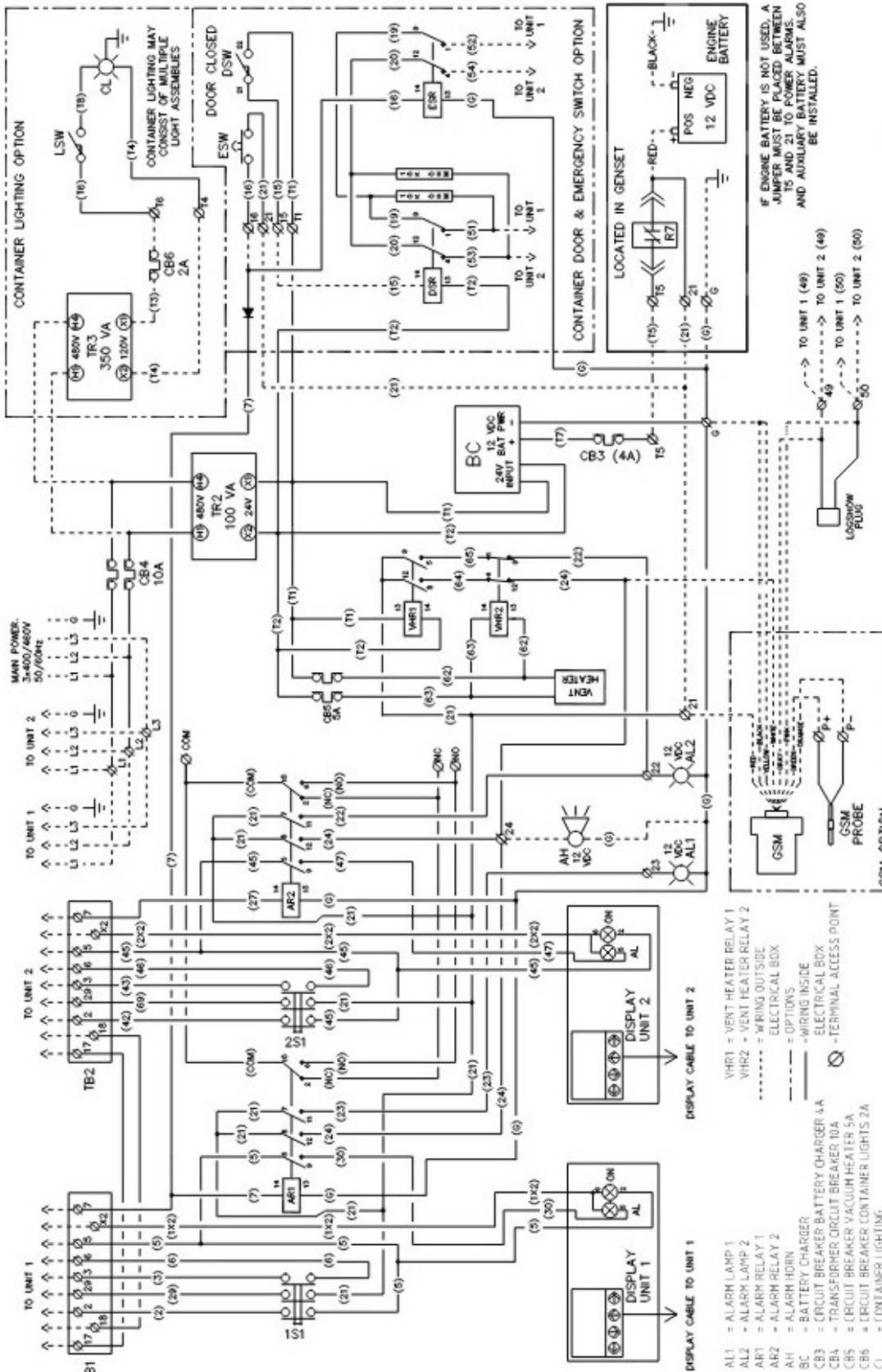

KLINGE
 4075 East Market Street, YORK PA 17402 USA
 For technical assistance: <https://www.klinge.com/request-service>
 Web portal: <https://www.klinge.com/request-service>
 Email: technical@klinge.com
 Telephone: +1-717-840-4500
 For spare parts please email: spares@klinge.com

ELECTRICAL DIAGRAM NMF-372 DISPLAY BOX K35-06706-00 REV F

IF ENGINE BATTERY IS NOT USED, A JUMPER MUST BE PLACED BETWEEN T5 AND Z1 TO POWER ALARMS AND AUXILIARY BATTERY MUST ALSO BE INSTALLED.

- AL1 = ALARM LAMP 1
 - AL2 = ALARM LAMP 2
 - AR1 = ALARM RELAY 1
 - AR2 = ALARM RELAY 2
 - AH = ALARM HORN
 - BC = BATTERY CHARGER
 - CB3 = CIRCUIT BREAKER BATTERY CHARGER 4A
 - CB4 = TRANSFORMER CIRCUIT BREAKER 10A
 - CB5 = CIRCUIT BREAKER VACUUM HEATER 5A
 - CB6 = CIRCUIT BREAKER CONTAINER LIGHTS 2A
 - CL = CONTAINER LIGHTING
 - DSR = DOOR SWITCH RELAY
 - DSW = DOOR SWITCH
 - ESR = EMERGENCY SWITCH RELAY
 - ESW = EMERGENCY SWITCH
 - ON = POWER ON LAMP
 - T5 = UNIT ON/OFF SWITCH 1
 - Z1 = UNIT ON/OFF SWITCH 2
 - TR2 = TRANSFORMER DISPLAY BOX
 - TR3 = TRANSFORMER CONTAINER LIGHTING
- VHR1 = VENT HEATER RELAY 1
 VHR2 = VENT HEATER RELAY 2
 --- = WIRING OUTSIDE ELECTRICAL BOX
 - - - = WIRING INSIDE ELECTRICAL BOX
 ⊗ = TERMINAL ACCESS POINT

SECTION 5. CONTROLLER INSTRUCTIONS AND SEQUENCE

5.1 GENERAL INFORMATION

The microprocessor controller system is based on the newest technology and consists of the following parts:

1. The microprocessor controller.
2. The display/keypad.
3. Temperature sensors.

Both system controllers are mounted in the electrical box. A display/keypad for each system is mounted in the display panel box, mounted on the changeover box door and all sensors are mounted in the unit.

It is recommended that a voltmeter or an ohmmeter be used for troubleshooting the system. Be careful because a short can cause damage to the electronic circuits. As control is related to resistance, an ohmmeter is required to check components.

The following will help you to understand the controller and the troubleshooting.
PLEASE READ IT ALL CAREFULLY.

Several time delays are incorporated in the controller and are not adjustable. Details of the time delays are explained later in this section under, CONTROLLER.

Accuracy is +/- 0.5°C max. Checking of temperature should be done with an instrument with equal or better accuracy.

5.2 CONTROLLER

(MPC3 software version min. #065)

This device contains all circuits necessary to select the required functions to maintain an accurate temperature. The selection is based on signals received from the sensors and the analog input. When the unit ON/OFF switch is put in "ON" position, the controller will go into "Start-up" mode and the display will show, BOOTING-KLINGECORP, NMF-372-DATE and TIME, for a few seconds, then it checks for the correct phase direction of the unit.

Display shows "Phase direction test, 0" while under test, and after the phase sensor relay determines which should be activated (PC, R1 or PC, R2) the display shows "Phase direction test 1." or "Phase direction test 2."

When the controller has determined the correct phase direction for the unit, the display shows the set point temperature (SP) and return air temperature. (RT)

These two temperatures are always shown in the display when the unit is switched "ON". The controller controls the temperature using the "return air" sensor temperature (RT), and regulated start/stop of the compressors. When the unit has reached set point, the evaporator fans will operate to maintain air circulation in the container.

CONTROLLER REGULAR SEQUENCE

The "set point menu" in the display is designed for setting of temperature:

Start:

If the return air temperature (RT) rises to 1°C above the set point (SP), the controller will call for cooling. The unit will start and will continue to run until the return air temperature reaches the set point, or for a minimum of 5 minutes, whichever is longer.

Stop:

If the return air temperature (RT) falls to 2°C below the set point (SP), the unit will stop and will not restart for a minimum of 5 minutes.

CONTROLLER STARTING SEQUENCE

The starting sequence table below, shows the start-up sequence:

Unit "ON/OFF" switch in "ON" position.

UNIT POWER ON.	
System start, App. 60 sec.	Evaporator fan on. <u>Next step: Delay 5 sec.</u> Phase sensor relay 1 on. <u>Next step: Delay 10 sec.</u> If load is <0.5A, then condenser fan relay on and alarm A30 is set. <u>Next step: Delay 10 sec.</u> Evap. fan relay off Cond. Fan relay off If phase direction is wrong, then PCR1 off and PCR2 on.
	<u>Next step: Delay 5 sec.</u> Evaporator fan on.
	<u>Next step: Delay 5 sec.</u> Compressor 1 on.
	<u>Next step: Delay 2 sec.</u> Condenser fan on.
	<u>Next step: Delay 3 sec.</u> Compressor 2 on.
	<u>Next step: Delay 27 sec.</u> Compressor 3 on.

CONTROLLER AUTO TEST SEQUENCE

The table below shows the Auto test sequence:
Unit "ON/OFF" switch in "ON" position.

Unit Auto test Start in menu Commands - Auto test		
System auto test.	AUTO TEST RUNNING 0.0 0.0 0.0 A	
	<u>Next step: Delay 5 sec.</u> Evap. fan run 1.0 1.0 1.0 A	Relay EFR on If fault, then text will be shown in display for 10 sec.
	<u>Next step: Delay 10 sec.</u> Cond. fan 1 run 1.0 1.0 1.0 A	Relay CFR on If fault, then text will be shown in display for 10 sec.
	<u>Next step: Delay 10 sec.</u> Comp. 1 R134 run 7.0 7.0 7.0 A	Relay CMR1 on Relay CFR on LSV valve on If fault, then text will be shown in display for 10 sec.
	<u>Next step: Delay 10 sec.</u> Comp. 2 R134 run 7.0 7.0 7.0 A	Relay CMR2 on Relay CFR on LSV valve on
	<u>Next step: Delay 4 sec.</u> Comp. 3 R23 run 8.0 8.0 8.0 A	Relay CMR3 on If fault, then text will be shown in display for 10 sec.
	<u>Next step: Delay 10 sec.</u> Defrost test 7.0 7.0 7.0 A	Relay CMR3 on HG valve on If fault, then text will be shown in display for 10 sec.
	<u>Next step: Delay 10 sec.</u> PUMP DOWN COMP.1 R23 6.11 17.3 B 134a 0.11 12.3 B	Relay CMR1 on Relay CFR on
	<u>Next step: Delay 10-60 sec.</u> Test status. TEST PASS OK Or TEST FAILED	Alarm code is displayed, see event log for info

Example of an event log from unit.

```
MPC3 temperature report
KLIU241045A NMF-372 sys 2
YY MM DD HH:MM Temp s Return Supply Defros Cargo Evap. Com Com Com Sys LP LP HP HP
19 02 28 07:30 -60.0 -60.2 -60.2 -60.7 -- 03.1 24 22 38 00 02.2 -0.1 05.0 01.2 477V 60Hz 1A 1A-14C 7.1V 10000000 1010000
19 02 28 07:24 -60.0 -59.9 -62.7 -62.9 -- 03.6 25 24 51 00 00.8 -0.2 09.0 02.0 465V 60Hz 20A 19A-14C 7.1V 110111100 1010000
19 02 28 07:18 -60.0 -60.2 -60.5 -61.2 -- 03.1 25 24 39 00 02.2 -0.1 06.0 01.2 477V 60Hz 1A 1A-13C 7.1V 100000000 1010000
19 02 28 07:12 -60.0 -59.9 -62.5 -63.4 -- 03.5 25 23 48 00 00.9 -0.2 09.2 02.0 462V 60Hz 20A 19A-13C 7.1V 110111100 1010000
19 02 28 07:06 -60.0 -60.3 -60.5 -61.0 -- 03.1 25 24 39 00 02.2 -0.1 05.6 01.2 477V 60Hz 1A 1A-13C 7.1V 100000000 1010000
19 02 28 07:00 -60.0 -59.9 -62.5 -63.2 -- 03.6 25 23 48 00 00.8 -0.2 09.2 02.0 465V 60Hz 19A 19A-13C 7.1V 110111100 1010000
19 02 28 06:54 -60.0 -60.5 -60.7 -61.2 -- 03.1 25 24 41 00 02.2 -0.1 05.8 01.2 477V 60Hz 1A 1A-14C 7.1V 100000000 1010000
19 02 28 06:48 -60.0 -59.5 -61.8 -63.5 -- 03.6 22 18 44 00 00.9 -0.2 09.4 02.0 465V 60Hz 20A 19A-14C 7.1V 110111100 1010000
19 02 28 06:42 -60.0 -60.5 -60.7 -61.7 -- 03.1 26 25 42 00 02.1 -0.1 06.8 01.2 477V 60Hz 1A 1A-14C 7.1V 100000000 1010000
19 02 28 06:36 -60.0 -59.4 -61.7 -63.5 -- 03.6 21 16 41 00 00.9 -0.2 09.6 02.0 462V 60Hz 19A 19A-14C 7.1V 110111100 1010000
19 02 28 06:30 -60.0 -60.2 -60.5 -61.0 -- 03.1 25 24 39 00 02.2 -0.1 05.4 01.2 477V 60Hz 1A 1A-14C 7.1V 100000000 1010000
```

5.3 DISPLAY

After initial start up both Unit 1 and Unit 2 LED displays show Set Point and Return Air readings. Press the UP button once to show Unit Mode, primary or secondary.



Unit 1 displays - SEC.: DELAY Unit 1 is secondary, waiting until it is necessary to control the system.
Unit 2 displays - PRIM: FREEZING Unit 2 is primary, working to keep the system at set point.

The LED display shows all information regarding all temperatures for unit sensors, all data recorded in data logger and all information for unit operating conditions.

DISPLAY MAIN MENU	(The display will always show the set point and the return air temperature in the display, except if a text message comes up.)		
Setpoint. "SP" Return "RT" Supply "SU" Defrost "DF" Cargo "CS" E FAN L "EL" Comp. 1 "C1" Comp. 2 "C2" Comp. 3 "C3" E FAN R "ER" R23 LOW "LO" 134 LOW "LO" R23 HIGH "HI" 134 HIGH "HI"	SETPOINT, shows the actual setting temperature RETURN, shows the temperature for return air sensor, mounted in return air from container cargo. SUPPLY, shows the temperature for supply air sensor, mounted in supply air to container cargo. DEFROST, shows the temperature for evaporator coil, mounted on suction pipe from evaporator at the TX valve sensor. CARGO, shows the temperature of the product core/surface temperature sensor. (Option.) Evap. Fan motor left, shows the temperature of the Evap. Left Fan motor sensor, mounted on motor housing. COMP 1, shows the temperature for compressor 1 sensor, mounted on discharge pipe comp 1 COMP 2, shows the temperature for compressor 2 sensor, mounted on discharge pipe comp 2 COMP 3, shows the temperature for compressor 3 sensor, mounted on discharge pipe comp 3 Evap. Fan motor right, shows the temperature of the Evap. Right Fan motor sensor, mounted on motor housing. R23 low, shows the low-pressure on R23 system, mounted on suction pipe from evaporator to crankcase press. regulator. R134 low, shows the low-pressure on R134a system, mounted on suction pipe to compressors 1 & 2. R23 high, shows the high-pressure on R23 system, mounted on condenser pipe to heat exchanger. R134 high, shows the high-pressure on R134a system, mounted on condenser pipe.		
Config	Container ID. KLIU1234567		
Datalogger	Event Log.	date/time, 01.03.23 16:00 all event Log.	Log Interval Set:6-60 Min. DATE / TIME 01.03.23 16:00 DEF.INTERVAL SET:3-99HOUR DEF.OFF.TEMP SET:5-30° C. DEF.MAX.TIME SET:15-99 MIN. Unit series no. xxxx.xxxxx
Unit Data	Temp. Log.	date/time, YY.MM.DD 16:00 temperat. sensor/ data:	Control setting Switch setting
Commands	Input	"RT"- "SU"- "DF"- "CS"- "EL"- "C1"- "C2"- "C3"- "ER"- "R23LO"- "134LO"- "R23HI"- "134HI"- "Relay- status"- "Volt"- "Hz"- "Amps"	
Alarms (*) (*) number of alarms.	Manual defrost	Return, RT. Supply, SU. Defrost, DF Cargo, CS. E Fan L. EL. Comp. 1,C1 Comp. 2,C2 Comp. 3,C3 E Fan R. ER. Pres.R23 LO Pres.134 LO Pres.R23 HI Pres.134 HI Mains volt Mains amp. Mains Hz. Amp. Ph 1. Amp. Ph 2. Amp. Ph 3. 6volt battery C.int. temp. Counter.	Not used. (Only for technical setting of Different Controller model.) Network no: Each controller can be code with no. from 1 to 4.
Mode (Setpoint SP.)	Manual test	Output	
	Run Auto Test	All relay on / off status. 12 relays + 4 PVM. %load	GMS. pin code SMS alarm1/2/3 Telephone NO. to mobile phone for SMS alarm. (Option.)
	Test SMS Alarm.	Run hour:	
		Total. Hour. E Fan. Cond.fan Not used Comp.1 Comp.2 Comp.3 Lsv, valve Hotgas val. No alarm.	SMS, person 1. SMS, person 2. SMS, person 3.
		Software	Newest data

5.4 KEYPAD

The four button Keypad gives access to all operations, for setting of temperature and scrolling through unit data information.
Keypad function

The keypad can be set to require a password for setting changes.

With the system operating, at the main screen

1. Scroll using the UP arrow to the Config Menu
2. Press the Right (Enter) arrow to enter the Config Menu
3. Scroll using the Down arrow to the Switch Settings
4. Press the Right arrow to access the Switch Settings
5. Scroll using the Down arrow to Password Protect
6. Press the Right arrow to access the Password setting
7. Use the Up arrow to turn the Password setting to ON
8. Press and hold the Right arrow until the display shows Save Change
9. Press the Left arrow until back to the main screen
10. The system will need about 15 minutes to recognize the new setting for a Pin Code
11. When trying to change the set point the display will now ask for the PW
12. Use the Up/Down arrows to enter FJ, then press the Right arrow
13. After FJ is entered there is a 15 minute period to change settings

Set point Press (→) for change Scroll, press (↓) or (↑)	Use (↓) or (↑) for scroll in setting of freezing temperature. Press (→) for change set point – XX.X°C. "Arrows flash". Enter new set point, press (→) 2 sec. Note. The value to be changed must be on the top line in the display.	Display show, save change.	
Unit sensor temperature Scroll, press (↓) or (↑)	Display shows temperature for all unit sensors and pressure transducers.		
Config >> Press (→) for enter Scroll, press (↓) or (↑) Esc. press (←)	Unit type. NMF-372. Scroll, press (↓) Esc. press (←) Container ID. >> "KLIU1234567" Press (→) for change. Scroll, press (↓) or (↑) Esc. press (←) Log interval. >> Press (→) for change. Scroll, press (↓) or (↑) Esc. press (←) Date and time. >> Press (→) for change. Scroll, press (↓) or (↑) Esc. press (←) Defrost interval. >> Press (→) for change. Scroll, press (↓) or (↑) Esc. press (←) Defrost termination >> Temperature. Press (→) for change. Scroll, press (↓) or (↑) Esc. press (←)	 KLIU1234567 ↑..... "Arrow flash" Change the first characters, 1. Use (↓) or (↑) for scroll 2. Use (→) to move to next character, and repeat no.1 Press (→) 2 sec. to enter new ID. no. "Arrows flash". Use (↓) or (↑) for changing log interval. Press (→) 2 sec. to enter new interval. Year 00-month 01-date 20. Time 12-min 30 ↑↓ (Arrows flash) Change the first value, 1. Use (↓) or (↑) for chance. 2. Use (→) to move to next item, and repeat 1 Press (→) 2 sec. to enter new date/time. "Arrows flash". (factory set. 24 hours.) Use (↓) or (↑) for changing defrost interval. Press (→) 2 sec. to enter new interval. "Arrows flash". (factory set. 18°C.) Use (↓) or (↑) for changing termination temperature. Press (→) 2 sec. to enter new temperature.	 Display show, save change. Display show, save change. Display show, save change. Display show, save change.

	<p>Defrost max. time. >> Press (→) for change. Scroll, press (↓) or (↑) Esc. press (←)</p> <p>Unit serial no. >> "69XXXXXXX" Press (→) for change. Scroll, press (↓) or (↑) Esc. press (←)</p> <p>Control setting. >> Press (→) for enter Scroll, press (↓) or (↑) Esc. press (←)</p> <p>Switch setting. >> Press (→) for change. Scroll, press (↓) or (↑) Esc. press (←)</p>	<p>"Arrows flash". (factory set. 45 min.) Use (↓) or (↑) for changing max. defrost time. Press (→) 2 sec. to enter new defrost time.</p> <p>"69XXXXXXX" ↑..... "Arrow flash" Change the first characters, 1. Use (↓) or (↑) for scroll 2. Use (→) to move to next character, and repeat no.1 Press (→) 2 sec. to enter new no.</p> <p>Not used. (Only for technical setting of different controller model.) Network No: Each controller can be coded with a no. from 1 to 4, if there is more than one Controller in the Klinge downloading system and if all Controllers are linked to the same PC Network.</p> <p>Unit temperature in °F.-Password- Alarm cargo sensor-PT1000 (set to ON) ext. (All values are ON/OFF functions, and not all are used for each unit model.) Use (↓) or (↑) to scroll in menu of settings. Press (→) for change in function. Use (↓) or (↑) to change ON/OFF. Press (→)2 sec. to enter new interval.</p>	<p>Display show, save change.</p> <p>Display show, save change.</p> <p>Display show, save change.</p>
<p>Config >> Press (→) for enter Scroll, press (↓) or (↑) Esc. press (←)</p>	<p>GMS. pin code >> Scroll, press (↓) or (↑) Esc. press (←)</p> <p>SMS alarm 1 / 2 / 3. >> "XXXXXXXXXX" "SMS alarm is Option" Press (→) for change. Scroll, press (↑) Esc. press (←)</p>	<p>If the unit is equipped with telephone modem, the pin code must be set to 4080 or de-activated.</p> <p>In "SMS alarm 1/2/3" you can select the telephone no. for max. 3 persons, to which the modem shall send the SMS alarm. ("Send SMS alarm" must be set to "ON" in Switch setting.) SMS alarm 1: Person no. 1. SMS alarm 2: Person no. 2. SMS alarm 3: Person no. 3.</p> <p>Insert selected telephone no.: "123456789----" ↑..... "Arrow flash" Change the first characters, 1. Use (↓) or (↑) to scroll 2. Use (→) to move to next character, and repeat no.1 Press (→) 2 sec. to enter new telephone no.1</p> <p>If person no. 1 does not respond to the SMS (Max.30 min. = 2 SMS calls) the SMS alarm will be sent to person no.2 or 3. (Only 1 call each.)</p>	<p>Display show, save change.</p>
<p>Datalogger >> Press (→) for enter. Scroll, press (↓) or (↑) Esc. press (←)</p>	<p>Temperature log. >> Press (→) for information Scroll, press (↓) Esc. press (←)</p> <p>Event log. >> Press (→) for information Scroll, press (↑) Esc. press (←)</p>	<p>Use (↓) or (↑) to scroll in time, and (←) or (→) to scroll in temperature. Esc. press (←)</p> <p>Use (↓) or (↑) to scroll in time and event log. Press (→) for more information. Press (←) for Esc.</p>	<p>Event log information Scroll, press (↓) or (↑) Esc. press (←)</p>
<p>Unit data >> Press (→) for enter. Scroll, press (↓) or (↑) Esc. press (←)</p>	<p>Input. >> Press (→) for enter. Scroll, press (↓) Esc. press (←)</p> <p>Output. >> Press (→) for enter. Scroll, press (↓) or (↑) Esc. press (←)</p> <p>Run hour. >> Press (→) for enter. Scroll, press (↓) or (↑) Esc. press (←)</p>	<p>All input data from system. Use (↑) or (↓) to scroll in menu. Esc. press (←)</p> <p>All output data to system. Use (↑) or (↓) to scroll in menu. Esc. press (←)</p> <p>All running hour for system. Use (↑) or (↓) to scroll in menu. Esc. press (←)</p>	

	Time to defrost. >> Scroll, press (↓) or (↑) Esc. press (←)	Display shows time to next defrost.	
	Software ID. >> Scroll, press (↑) Esc. press (←)	Display shows software ID.	
Commands >> Press (→) for enter. Scroll, press (↓) or (↑) Esc. press (←)	Manual defrost. >> Press (→) for enter. Scroll, press (↓) Esc. press (←)	Display shows defrost.	
	Manual test. >> Press (→) for enter. Scroll, press (↓) or (↑) Esc. press (←)	relay, energized =1, de-energized =0 1 0 0 0 0 0 0 0 0 0 0 0 0 0 0 0 ↑ Use (↓) or (↑) for scroll, and (→) for ON/OFF (1/0) between relays. Esc. press (←)	
	Run auto test. >> Press (→) for enter. Scroll, press (↓) or (↑) Esc. press (←)	The display shows the actual parts which are tested, and the load current of that part. (Motor-compressor e.g.) Esc. press (←)	(The test result is also shown in the Event log)
	Test SMS alarm >> Press (→) for enter. Scroll, press (↑) Esc. press (←)	The controller will set up the Modem and send a SMS alarm status to telephone no. for person 1, in the controller alarm list.	
Alarm. >> Press (→) for enter. Scroll, press (↓) or (↑) Esc. press (←)	Display shows current alarm, or no alarm. Press (→) to cancel alarm.		
Mode. >> Press (→) for enter. Scroll, press (↓) or (↑) Esc. press (←)	Display shows current operating mode. (Delay- Airflow- Freezing- Defrost)		

5.5 NMF-372 Cargo Alarm Functionality

(MPC3 software version min. sw084)

A Cargo Alarm High/Low setting has been added in sw084 (and newer) that allows hard set Cargo Alarms. Cargo probes must be present, or added to the Unit for the Cargo Alarm features to be active. The steps below describe how to set the Cargo Alarms using the MPC3 controller display pad controls.

Cargo Alarm On/Off Setting

1. From the main screen **SCROLL** (Up/Down) to the **CONFIG** menu and press **ENTER**.
2. Follow this path using **SCROLL** and **ENTER** buttons.
 - a. **CONFIG → Switch setting → Cargo sens.alarm**
3. **SCROLL** (Up/Down) to toggle the **Cargo sens.alarm** On/Off and hold the **ENTER** button for 3 seconds to save the setting. Use the **ESC** button to return to the last menu.

Cargo Alarm Delay Setting (Default 20 = 2 hours, settable 1 = 6 minutes to 250 = 25 hours)

1. From the main screen **SCROLL** (Up/Down) to the **CONFIG** menu and press **ENTER**.
2. Follow this path using **SCROLL** and **ENTER** buttons.
 - a. **CONFIG → CONTROL sett. → Al. Cargo delay .h**
3. **SCROLL** (Up/Down) to toggle the **Al. Cargo delay .h** value and hold the **ENTER** button for 3 seconds to save the setting. Use the **ESC** button to return to the last menu.

NOTE: Cargo Alarm Delay time is 4x at startup if unit has not been INRANGE.

Cargo Alarm High/Low Setting (Default H = 0.0°C & L = 0.0°C, settable -80.0°C to 25°C)

1. From the main screen **SCROLL** (Up/Down) to the **CONFIG** menu and press **ENTER**.

2. Follow this path using SCROLL and ENTER buttons.
 - b. CONFIG → Cargo alarm.
3. SCROLL (Up/Down) to cargo set high alarm or cargo set low alarm and press ENTER.
4. SCROLL (Up/Down) to set desired temperature setting and hold ENTER for 3 seconds to save the setting.

NOTE: The Cargo Alarm High/Low temperature settings must be $\geq 2.0^{\circ}\text{C}$ apart or the feature will not be active and normal INRANGE setting will be used.

5.6 TEMPERATURE SENSOR NTC (ONLY AMBIENT SENSOR)

The temperature sensor is an NTC thermistor element, placed in a sealed metal tube, which is connected to a two-conductor cable. The temperature signal from the sensor is relayed to the controller through this cable. The accuracy of this will not change, except for an internal malfunction of the sensor itself. If one of the sensors has an open/short circuit, the current alarm will be shown in display as “----sensor out of range”

Use an ohmmeter only to check Ohm “Ω”. Readings should agree with the following chart:

Sensor NTC									
°C	Ω	°C	Ω	°C	Ω	°C	Ω	°C	Ω
120	109.84	88	251.41	56	662.22	24	2073.18	-8	8131.44
119	112.51	87	258.55	55	684.36	23	2155.36	-9	8524.23
118	115.26	86	265.92	54	707.36	22	2241.30	-10	8938.65
117	118.09	85	273.54	53	731.27	21	2331.21	-11	9376.03
116	121.00	84	281.42	52	756.11	20	2425.28	-12	9837.80
115	124.00	83	289.57	51	781.93	19	2523.74	-13	10325.47
114	127.09	82	297.99	50	808.77	18	2626.82	-14	10840.65
113	130.27	81	306.70	49	836.69	17	2734.74	-15	11385.08
112	133.55	80	315.72	48	865.73	16	2847.79	-16	11960.60
111	136.92	79	325.04	47	895.93	15	2966.22	-17	12569.21
110	140.39	78	334.69	46	927.36	14	3090.32	-18	13213.00
109	143.93	77	344.68	45	960.07	13	3220.41	-19	13849.25
108	147.66	76	355.01	44	994.11	12	3356.80	-20	14615.38
107	151.47	75	365.71	43	102.55	11	3499.83	-21	15378.98
106	155.38	74	376.79	42	106.46	10	3649.88	-22	16187.84
105	159.42	73	388.26	41	110.90	9	3807.32	-23	17044.94
104	163.59	72	400.14	40	1144.94	8	3972.57	-24	17953.48
103	167.88	71	412.45	39	1186.66	7	4146.05	-25	18916.88
102	172.31	70	425.21	38	1230.14	6	4328.24	-26	19938.83
101	176.87	69	438.42	37	1275.46	5	4519.61	-27	21023.28
100	181.58	68	452.12	36	1322.70	4	4720.69	-28	22174.47
99	186.44	67	466.31	35	1371.97	3	4932.03	-29	23396.95
98	191.45	66	481.03	34	1423.36	2	5154.22	-30	24695.63
97	196.62	65	496.29	33	1476.96	1	5387.87	-31	26075.77
96	201.96	64	512.12	32	1532.90	+/-0	5633.65	-32	27543.04
95	207.47	63	528.54	31	1591.28	-1	5892.27	-33	29103.54
94	213.16	62	545.57	30	1652.21	-2	6164.47	-34	30763.82
93	219.03	61	563.24	29	1715.84	-3	6451.05	-35	32530.96
92	225.10	60	581.58	28	1782.24	-4	6752.87	-36	34412.57
91	231.36	59	600.62	27	1851.70	-5	7070.82	-37	36416.87
90	237.83	58	620.39	26	1924.22	-6	7405.87	-38	38552.70
89	244.51	57	640.91	25	2000.00	-7	7759.04	-39	40829.62

5.7 TEMPERATURE SENSOR PT1000

The temperature sensor is a PT 1000 thermistor element, placed in a sealed metal tube, which is connected to a two-conductor cable. The temperature signal from the sensor is relayed to the controller through this cable.

The accuracy of this will not change, except for an internal malfunction of the sensor itself. If one of the sensors has an open/short circuit, the current alarm will be shown in display as “----sensor out of range”

Use an ohmmeter only to check Ohm “Ω“. Readings should agree with the following chart:

SENSOR PT1000											
°C	Ω	°C	Ω	°C	Ω	°C	Ω	°C	Ω	°C	Ω
120	1460.6	88	1339.4	56	1217.0	24	1093.5	-8	968.7	-40	842.7
119	1456.8	87	1335.6	55	1213.2	23	1089.6	-9	964.8	-41	838.8
118	1451.1	86	1331.8	54	1209.3	22	1085.7	-10	960.9	-42	834.8
117	1449.3	85	1328.0	53	1205.5	21	1081.8	-11	956.9	-43	830.8
116	1445.5	84	1324.2	52	1201.6	20	1077.9	-12	953.0	-44	826.9
115	1441.7	83	1320.4	51	1197.8	19	1074.0	-13	949.1	-45	822.9
114	1438.0	82	1316.6	50	1194.0	18	1070.2	-14	945.2	-46	818.9
113	1434.2	81	1312.7	49	1190.1	17	1066.3	-15	941.2	-47	815.0
112	1430.4	80	1308.9	48	1186.2	16	1062.4	-16	937.3	-48	811.0
111	1426.6	79	1305.1	47	1182.4	15	1058.5	-17	933.4	-49	807.0
110	1422.9	78	1301.3	46	1178.5	14	1054.6	-18	929.5	-50	803.1
109	1419.1	77	1297.5	45	1174.7	13	1050.7	-19	925.5	-51	799.1
108	1415.3	76	1293.7	44	1170.8	12	1046.9	-20	921.5	-52	795.1
107	1411.5	75	1289.8	43	1167.0	11	1042.9	-21	917.7	-53	791.1
106	1407.7	74	1286.0	42	1163.1	10	1039.0	-22	913.7	-54	787.2
105	1403.9	73	1282.2	41	1159.3	9	1035.1	-23	909.3	-55	783.2
104	1400.2	72	1278.4	40	1155.4	8	1031.2	-24	905.9	-56	779.2
103	1396.4	71	1274.5	39	1151.5	7	1027.3	-25	901.9	-57	775.2
102	1392.6	70	1270.7	38	1147.7	6	1023.4	-26	898.0	-58	771.3
101	1388.8	69	1266.9	37	1143.8	5	1019.5	-27	894.0	-59	767.3
100	1385.0	68	1263.1	36	1139.9	4	1015.6	-28	890.1	-60	763.3
99	1381.2	67	1259.2	35	1136.1	3	1011.7	-29	886.2	-61	759.3
98	1377.4	66	1255.4	34	1132.2	2	1007.8	-30	882.2	-62	755.3
97	1373.6	65	1251.6	33	1128.3	1	1003.9	-31	878.3	-63	751.3
96	1369.8	64	1247.7	32	1124.5	+/- 0	1000	-32	874.3	-64	747.3
95	1366.0	63	1243.9	31	1120.6	-1	996.1	-33	870.4	-65	743.3
94	1362.2	62	1240.1	30	1116.7	-2	992.2	-34	866.4	-66	739.3
93	1358.4	61	1236.2	29	1112.8	-3	988.3	-35	862.5	-67	735.3
92	1354.6	60	1232.4	28	1109.0	-4	984.4	-36	858.5	-68	731.3
91	1350.8	59	1228.6	27	1105.1	-5	980.4	-37	854.8	-69	727.3
90	1347.0	58	1224.7	26	1101.2	-6	976.5	-38	850.6	-70	723.3
89	1343.2	57	1220.9	25	1097.3	-7	972.6	-39	846.7	NF. Temp. Chart.	

5.8 TEMPERATURE CONVERSION TABLES

The numbers in bold-face type in the center column refer to the temperature, either in Centigrade or in Fahrenheit, which is to be converted to the other scale. Converting Fahrenheit to Centigrade, the equivalent temperature will be found in the left column.

TEMPERATURE			TEMPERATURE			TEMPERATURE			TEMPERATURE		
°C	°C - °F	°F	°C	°C - °F	°F	°C	°C - °F	°F	°C	°C - °F	°F
-40.0	-40	-40.0	-6.7	+20	+68.0	+26.7	+80	+176.0	+60.0	+140	+284.0
-39.4	-39	-38.2	-6.1	+21	+69.8	+27.2	+81	+177.8	+60.6	+141	+285.8
-38.9	-38	-36.4	-5.5	+22	+71.6	+27.8	+82	+179.6	+61.1	+142	+287.6
-38.3	-37	-34.6	-5.0	+23	+73.4	+28.3	+83	+181.4	+61.7	+143	+289.4
-37.8	-36	-32.8	-4.4	+24	+75.2	+28.9	+84	+183.2	+62.2	+144	+291.2
-37.2	-35	-31.0	-3.9	+25	+77.0	+29.4	+85	+185.0	+62.8	+145	+293.0
-36.7	-34	-29.2	-3.3	+26	+78.8	+30.0	+86	+186.8	+63.3	+146	+294.8
-36.1	-33	-27.4	-2.8	+27	+80.6	+30.6	+87	+188.6	+63.9	+147	+296.6
-35.6	-32	-25.6	-2.2	+28	+82.4	+31.1	+88	+190.4	+64.4	+148	+298.4
-35.0	-31	-23.8	-1.7	+29	+84.2	+31.7	+89	+192.2	+65.0	+149	+300.2
-34.4	-30	-22.0	-1.1	+30	+86.0	+32.2	+90	+194.0	+65.6	+150	+302.0
-33.9	-29	-20.2	-0.6	+31	+87.8	+32.8	+91	+195.8	+66.1	+151	+303.8
-33.3	-28	-18.4	0.0	+32	+89.6	+33.3	+92	+197.6	+66.7	+152	+305.6
-32.8	-27	-16.6	+0.6	+33	+91.4	+33.9	+93	+199.4	+67.2	+153	+307.4
-32.2	-26	-14.8	+1.1	+34	+93.2	+34.4	+94	+201.2	+67.8	+154	+309.2
-31.7	-25	-13.0	+1.7	+35	+95.0	+35.0	+95	+203.0	+68.3	+155	+311.0
-31.1	-24	-11.2	+2.2	+36	+96.8	+35.6	+96	+204.8	+68.9	+156	+312.8
-30.6	-23	-9.4	+2.8	+37	+98.6	+36.1	+97	+206.6	+69.4	+157	+314.6
-30.0	-22	-7.6	+3.3	+38	+100.4	+36.7	+98	+208.4	+70.0	+158	+316.4
-29.4	-21	-5.8	+3.9	+39	+102.2	+37.2	+99	+210.2	+70.6	+159	+318.2
-28.9	-20	-4.0	+4.4	+40	+104.0	+37.8	+100	+212.0	+71.1	+160	+320.0
-28.3	-19	-2.2	+5.0	+41	+105.8	+38.3	+101	+213.8	+71.7	+161	+321.8
-27.8	-18	-0.4	+5.5	+42	+107.6	+38.9	+102	+215.6	+72.2	+162	+323.6
-27.2	-17	+1.4	+6.1	+43	+109.4	+39.4	+103	+217.4	+72.8	+163	+325.4
-26.7	-16	+3.2	+6.7	+44	+111.2	+40.0	+104	+219.2	+73.3	+164	+327.2
-26.1	-15	+5.0	+7.2	+45	+113.0	+40.6	+105	+221.0	+73.9	+165	+329.0
-25.6	-14	+6.8	+7.8	+46	+114.8	+41.1	+106	+222.8	+74.4	+166	+330.8
-25.0	-13	+8.6	+8.3	+47	+116.6	+41.7	+107	+224.6	+75.0	+167	+332.6
-24.4	-12	+10.4	+8.9	+48	+118.4	+42.2	+108	+226.4	+75.6	+168	+334.4
-23.9	-11	+12.2	+9.4	+49	+120.2	+42.8	+109	+228.2	+76.1	+169	+336.2
-23.3	-10	+14.0	+10.0	+50	+122.0	+43.3	+110	+230.0	+76.7	+170	+338.0
-22.8	-9	+15.8	+10.6	+51	+123.8	+43.9	+111	+231.8	+77.2	+171	+339.8
-22.2	-8	+17.6	+11.1	+52	+125.6	+44.4	+112	+233.6	+77.8	+172	+341.6
-21.7	-7	+19.4	+11.7	+53	+127.4	+45.0	+113	+235.4	+78.3	+173	+343.4
-21.1	-6	+21.2	+12.2	+54	+129.2	+45.6	+114	+237.2	+78.9	+174	+345.2
-20.6	-5	+23.0	+12.8	+55	+131.0	+46.1	+115	+239.0	+79.4	+175	+347.0
-20.0	-4	+24.8	+13.3	+56	+132.8	+46.7	+116	+240.8	+80.0	+176	+348.8
-19.4	-3	+26.6	+13.9	+57	+134.6	+47.2	+117	+242.6	+80.6	+177	+350.6
-18.9	-2	+28.4	+14.4	+58	+136.4	+47.8	+118	+244.4	+81.1	+178	+352.4
-18.3	-1	+30.2	+15.0	+59	+138.2	+48.3	+119	+246.2	+81.7	+179	+354.2
-17.8	0	+32.0	+15.6	+60	+140.0	+48.9	+120	+248.0	+82.2	+180	+356.0
-17.2	+1	+33.8	+16.1	+61	+141.8	+49.4	+121	+249.8	+82.8	+181	+357.8
-16.7	+2	+35.6	+16.7	+62	+143.6	+50.0	+122	+251.6	+83.3	+182	+359.6
-16.1	+3	+37.4	+17.2	+63	+145.4	+50.6	+123	+253.4	+83.9	+183	+361.4
-15.6	+4	+39.2	+17.8	+64	+147.2	+51.1	+124	+255.2	+84.4	+184	+363.2
-15.0	+5	+41.0	+18.3	+65	+149.0	+51.7	+125	+257.0	+85.0	+185	+365.0
-14.4	+6	+42.8	+18.9	+66	+150.8	+52.2	+126	+258.8	+85.6	+186	+366.8
-13.9	+7	+44.6	+19.4	+67	+152.6	+52.8	+127	+260.6	+86.1	+187	+368.6
-13.3	+8	+46.4	+20.0	+68	+154.4	+53.3	+128	+262.4	+86.7	+188	+370.4
-12.8	+9	+48.2	+20.6	+69	+156.2	+53.9	+129	+264.2	+87.2	+189	+372.2
-12.2	+10	+50.0	+21.1	+70	+158.0	+54.4	+130	+266.0	+87.8	+190	+374.0
-11.7	+11	+51.8	+21.7	+71	+159.8	+55.0	+131	+267.8	+88.3	+191	+375.8
-11.1	+12	+53.6	+22.2	+72	+161.6	+55.6	+132	+269.6	+88.9	+192	+377.6
-10.6	+13	+55.4	+22.8	+73	+163.4	+56.1	+133	+271.4	+89.4	+193	+379.4
-10.0	+14	+57.2	+23.3	+74	+165.2	+56.7	+134	+273.2	+90.0	+194	+381.2
-9.4	+15	+59.0	+23.9	+75	+167.0	+57.2	+135	+275.0	+90.6	+195	+383.0
-8.9	+16	+60.8	+24.4	+76	+168.8	+57.8	+136	+276.8	+91.1	+196	+384.8
-8.3	+17	+62.6	+25.0	+77	+170.6	+58.3	+137	+278.6	+91.7	+197	+386.6
-7.8	+18	+64.4	+25.6	+78	+172.4	+58.9	+138	+280.4	+92.2	+198	+388.4
-7.2	+19	+66.2	+26.1	+79	+174.2	+59.4	+139	+282.2	+92.8	+199	+390.2

SECTION 6. MAINTENANCE AND SERVICE INSTRUCTION

This section provides procedures for establishing preventive maintenance and systematic servicing schedules, which are the keys to successful operation.

6.1 SAFETY

- a. When any work is to be done on the components of the refrigeration system, always make sure that the equipment cannot be started automatically or accidentally. If valves are closed and/or circuits interrupted during service procedures, the control switches should be suitably tagged with such notations.
- b. Use proper tools and correct size of wrenches.
- c. Do not exert excessive pressure when tightening flare nuts, as it may result in a rupture of the flare or stripped threads.
- d. Always wear approved goggles or eye shields when working with the refrigerant to prevent eye injury if the refrigerant is accidentally discharged into the face of the service engineer.
- e. Never under any circumstances apply heat to a refrigerant cylinder by using a naked flame. Should it be considered necessary to apply heat to a cylinder to create a refrigerant flow when recharging a system, place the cylinder in a container of hot or warm water to a point about 3/4 of the height of the cylinder.

Even this method requires that a pressure gauge is in use in the charging line to indicate the pressure in the cylinder at all times.

Also, never close the shut off valve on the cylinder while the cylinder is being heated.

The use of a manifold gauge set will permit compliance with having a gauge in the line and a shut off valve on the manifold to stop the flow of refrigerant into the system and allow the gauge to read cylinder pressure.

- f. Always replace refrigerant cylinder valve and connection caps after using the cylinder, and do not permit a cylinder to be dropped or hit severely by another object.
- g. Due to the height at which the refrigeration unit is placed in the container always use safe and secure means to service the unit and to allow a platform for tools and a refrigerant cylinder.
- h. Never loosen a refrigerant line rapidly if there is positive pressure in the line:
 1. Because liquid refrigerant may give you a severe cold burn, or other injury.
 2. Because gas refrigerant may also cause oil to discharge, leaving the compressor short of oil, and creating an oily mess over the unit and service engineer.

6.2 CHECK REFRIGERANT R134a CHARGE

Checking with the unit operating.

It should be noted and remembered that the only requirement of liquid level is that a seal be maintained at the outlet of the receiver. At low refrigerant flow rate, the liquid refrigerant may not accumulate in the receiver to a point where a liquid level will show on the sight glass. Many times, the liquid will hang up in the condenser; therefore, caution should be taken before adding refrigerant. Air in the receiver may also prevent the level from coming up into the sight glass. If the refrigerant is not visible in the sight glass, it is recommended that the pressures be checked according to the suction and the discharge pressures noted on the graphs provided before determining that the charge is low. It is just as possible to do harm to the system by overcharging, as it is to run it undercharged.

It is important to have the correct amount of refrigerant in the system. If there is too little, the expansion valve will pass vapor and reduce the capacity of the evaporator. Too much refrigerant will result in higher head pressures and oil dilution.

The liquid level should be visible in the sight glass.

Caution:

An air-cooled system will operate at many different ambient temperatures and the performance of the system will vary accordingly. Therefore, before adding any refrigerant (or making any other adjustments), it should be taken into consideration whether the unit is running with a low temperature load or a high temperature load, running in a cold ambient or a hot ambient load and most important whether the suction and the discharge pressures are in line for existing conditions.

Note:

Unit capacity will be greatly reduced when high temperature ambient is experienced; therefore, a careful check should be made of unit performance before making any adjustments or adding refrigerant to the system. Before adding refrigerant, always determine the reason for the low charge and remedy the cause. Leak test thoroughly with an electronic leak detector and check also for traces of oil.

Caution:

When the refrigerant charge is added, it is important initially to purge the air from the transfer tubes of the manifold gauge set.

For charge quantity for the system; see Section 8.

6.3 CHECK REFRIGERANT R23 CHARGE

Note:

Check only with unit in STANDBY.

R23 refrigerant is best controlled at standby on an empty container (before power connection).

When no parts of the cooling system are cold (below -5°C .) the entire R23 charge will be gas, and pressure will show the total pressure of the gas charge.

It is important that the R134a compressor is not operating, and that the heat exchanger has cooled. (There must not be frost or ice on the heat exchanger pipe stubs.)

Factory filling = 14 bar at 20°C .

15 bar at 30°C .

16 bar at 40°C .

If the standby pressure is between 14 and 17 bar the unit is fully functional, and there should be no correction made to the charge.

When the standby pressure is above 17 bar there is risk for high-pressure cut out at start up with hot container, and it is necessary to reduce pressure to 17 bar.

Overcharging can easily happen if the system is filled when the unit is working.

If the standby pressure is between 11 and 13 bar the unit is working at reduced capacity but may maintain temperature between -45 to -50 deg. C.

Note: During standby both high and low-pressure transducers must show the same pressure.

CORRECT R23 CHARGE "RUNNING"

Since there is great risk to overcharge while operating, there should be no recharging if the container can maintain the required set point or during cool down maintain a temperature difference between return and supply at app. 4°C .

If there is a leak of R23 refrigerant, the R23 high-pressure will be lower than normal.

A sight glass is mounted on the R23 return liquid pipe from the heat exchanger, to control the R23 charging while operating. (Must be clear when return air temperature is below -40°C)

6.4 PROCEDURE FOR ADDING REFRIGERANT R134a

Checking when the unit is operating.

- a. Remove the compressor suction service valve cap. Connect the charging line to the refrigerant cylinder and tighten the connection.
- b. Crack open the cylinder valve and the manifold suction gauge valve and allow the entire line to purge the air, then tighten the connections at the compressor.
- c. With the system still operating and the suction pressure being 4 bar or below, and the cylinder pressure at 10 bar (dependent upon room temperature), open the refrigerant cylinder liquid valve completely and the manifold suction valve.
- d. Allow refrigerant into the system and observe the receiver sight glass (20-30 second bursts with a 5 minute interval).
- e. When it is determined that the system has an adequate refrigerant charge, close the refrigerant cylinder valve (if not already closed) and the manifold suction gauge valve, in that order. Remove the manifold lines and replace the caps securely.

6.5 PROCEDURE FOR ADDING REFRIGERANT R23

CHARGING R23

The pressure in the bottle is higher than the unit system pressure, while operating, therefore it is more secure to fill directly to the buffer tank without use of manometer, in the following way:

Mount the ¼ inch standard flare hose on the Schrader adapter without opening the Schrader valve (use the end of the hose without the “Schrader activator”). Mount the “Schrader activator end” of the hose to the R23 bottle. This order will avoid leakage between the system and the bottle pressure. The pressure from the bottle easily opens the Schrader valve during charging.

NOTE: It is important initially to purge the air from the transfer hose, by loosening the hose adapter nut, on the Schrader adapter.

Now slowly open the bottle, until a flow can be heard.

At standby,

R23 is charged, until both transducers show 14 bar at 20° C. ambient.

When the unit is working,

R23 charging is slowly performed until the sight glass is fully covered by liquid.

6.7 OPENING R134a SYSTEM

Whenever it is necessary to open a charged or functioning system to make repairs or replacements, it is necessary to discharge the refrigerant from that part of the refrigerant circuit before the system is opened. If the final pressure is reduced to less than atmospheric, sufficient refrigerant should be bled into the evacuated part of the system to raise the pressure to approx. 0 bar. Connections may then be broken, and the necessary repairs made.

Extreme care must always be taken to prevent the entrance of moisture and dirt into the system.

The use of “EASY-FLOW” silver solder and flux, or equivalent, is recommended in the refrigerant system piping. Do not use soft solder.

Prior to disturbing any connections, the type of solder originally used should first be verified, then continue. By taking this precaution, contamination of the joint will be avoided.

6.8 OPENING R23 SYSTEM

Whenever it is necessary to open a charged or functioning system to make repairs or replacements, it is necessary to discharge the R23 from the refrigerant circuit to the lowest positive pressure before the system is opened. To do that follow instructions below:

1. Connect a recycle pump with service hose between the ¼ inch service adapter on the R23 system suction side and the ¼ inch valve on an approved tank for R23 gas.
CAUTION. The volume of the tank must be at least 40 liters to take the whole charge from the unit. The pressure in the tank must not at any time exceed the pressure that the tank is approved for.
2. Connect a vacuum pump to both hoses on the recycle pump and take the system down to full vacuum.
3. Close the connection to the vacuum pump.
4. Open valves on the service hose “shut of valve”, as well as the suction service valve and start the recycle pump. Operate the pump until the R23 gas is pumped over to the approved tank for R23 gas.
5. After the system is repaired or part has been replaced, the system must be leak tested. (See section 6.9)
6. Draw a vacuum on R23 system.
(See section 6.10)
7. By reversing the hoses on the recycle pump all the R23 gas can be pumped back to the R23 piping system at the unit.

6.9 TESTING FOR LEAKS

The preferred method for finding leaks is by use of an electronic leak detector. There are several different makes available and they all use the same method of detecting a leak through an exploring tube, which will detect from large to extremely small leaks depending on the setting used on the detector.

Leak testing with soapsuds will reveal only the large leaks and is therefore ineffective in determining the tightness of a system.

To provide the best possible condition for leak checking the system, it is recommended that the pressure in the refrigerant system, to be increased by adding dry nitrogen to create a pressure suitable for checking.

6.10 VACUUM THE SYSTEM

Caution:

Do not use the compressor as a vacuum pump or as an air compressor. It is not designed to handle air and will not pull down to as low a vacuum as a pump designed for that purpose. Similarly, if used to compress air, serious overheating and consequent damage may be the result.

Connect a pump capable of drawing a vacuum of 0.15 mm HG or better to that part of the system which has been opened. Continue until all air and moisture have been removed.

The final evacuation may be accelerated, however, by manifolding the connections to the vacuum pump and evacuating simultaneously the high and the low sides of the system, the vacuum should be broken by introducing refrigerant.

Too much emphasis cannot be placed on the importance of keeping the system free of moisture. Slight amounts of water in the system will inevitably lead to trouble in the following forms:

- a. Corrosion of the steel parts.
- b. Copper plating of the shaft and the bearing.
- c. Sludging or gumming of the oil.
- d. Plugging of the strainers and the driers.
- e. Freezing and plugging of the expansion valve.

6.11 REFRIGERANT R134a /R23, TEMPERATURE / PRESSURE TABLE

The table shows the pressure and temperature between the two refrigerant systems, with a ΔT at 5° to 10°C on the heat exchange between high-pressure in the R23 system, and low-pressure in the R134a system.

Refrigerant pressure BAR

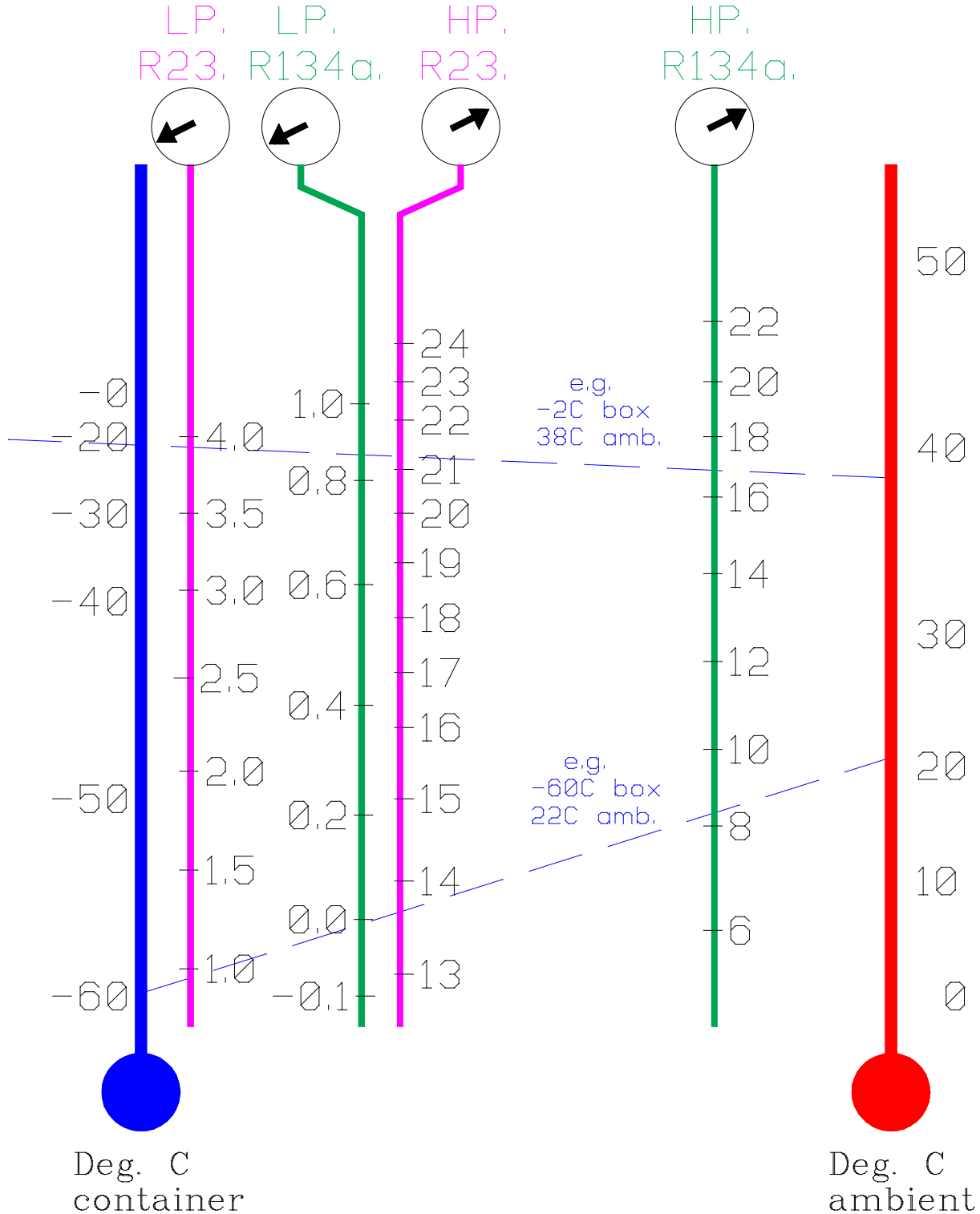

SECTION 7. SERVICING COMPONENTS

7.1 COMPRESSOR (R134a / R23)

COMPRESSOR MOTOR PROTECTION

The scroll compressor motors, in the R134a/R23 systems are equipped with an internal overload / overheat device. This device will break the circuit and stop the compressor, if any problem causes the motor to overheat. When the motor cools sufficiently the overload will reset automatically.

CAUTION:

The scroll compressor will only compress in one rotational direction, it is important to ensure the proper rotation direction when the compressor is started. Reverse rotation results in a sound level above what is normal in correct rotation, and there will be no reaction in suction – and discharge pressure.

COMPRESSOR LUBRICATION

To check the oil level in the compressor, a sight glass is provided in the front of the shell, allowing the oil inside to be visible at all times.

Before the system is started, each compressor sight glass should be approximately ¼ full of oil. Because the oil level will vary with operating conditions, it should be checked again after the compressor has been running long enough for the crankcase to warm up to operating conditions. The level in the sight glass must be visible when the compressor is running. If the level is low, oil should be added, to max. 1/2 level sight glass.

(Note: Oil levels in compressor 1 and compressor 2 will vary during operation. It is important oil is present in both compressors' sight glasses.)

ADDING OIL

There is no means of pouring oil into the compressor as there is on hermetic compressors, therefore oil must be sucked into the crankcase by way of the suction service valve.

When adding oil, the compressor must be separated from the system, close the liquid valve to empty the compressor of refrigerant.

Although this procedure is relatively simple, some preparations and care must be taken as follows:

Use a standard oil filling hand pump.

Or use a vacuum pump as follow:

- a. Connect vacuum pump to the Schrader valve on the compressor suction side.
- b. Connect a charging hose to the "oil level Schrader valve" (placed level with sight glass).
- c. Now place the end of the charging hose into the can of oil and start the vacuum pump. Continue to take the pressure to vacuum, and pull the oil into the crankcase, and observe the oil level in the compressor sight glass.
- d. When enough oil has been transferred to the compressor, disconnect charging hose. For comp.1 (R134a), the vacuum pump must draw a vacuum of 0,15 mm HG. or better in the compressor, then open the liquid valve and start the unit.
- e. Allow the unit to run 30 minutes before re-checking the oil level in the compressor sight glass, immediately after the compressor has been shut off.

Note:

Always keep commercial oil stored in sealed containers. Oil exposed to the atmosphere will absorb moisture, which can cause damage when introduced into the system. Use only the grades of oil which are suitable and recommended for compressor lubrication and have been specially processed to have the necessary low moisture content. The following oils are suitable:

Mobil Ester oil EAL 22CC

ICI Emkarate RL32CF

(Both oils are miscible)

P/N 6090.7026 (4 l. can)

COMPRESSOR MOTOR BURN-OUT

When a hermetic motor burn-out occurs, the stator winding insulation decomposes forming carbon, water, and acid. To prevent contamination of the refrigerant system and repeat the motor failures, steps must be taken to ensure that the refrigerant circuit is kept clean from contamination.

Important:

Damage to a compressor caused by failure to clean the system properly after burn-out constitutes abuse and is not covered by the terms of the warranty.

Note:

After it has been observed that a hermetic motor has failed either by observing an obvious electrical fault or by a strong burned odor to the refrigerant gas released at the discharge valve port, the following procedure must be followed to clean the system and thus prevent failure of a replacement compressor.

Caution:

Acids are formed during a motor burn-out. Use rubber gloves and eye protection, when working on the system or handling contaminated parts.

Moisture is a normal product of decomposition and is very harmful in a refrigeration system. However, it is one of the easiest products to remove. Acids, both hydrochloric and hydrofluoric, are generated. Both are highly corrosive and hydrofluoric acid will also attack glass.

Note: The etching of various sight glasses around the system will give an indication of the extent of contamination. The acid, most of which concentrates in the compressor oil, must be removed to prevent failure of the replacement compressor.

CLEAN OUT PROCEDURE

- a. To recover the refrigerant from the system, use a recover or reclaim system, so that the refrigerant can be reused.
- b. Replace the oil in the compressor.
- c. Replace the drier (replace the moisture indicator, if necessary).
- d. Evacuate the system.

Note:

It is vital to use a high stage vacuum pump to eliminate any moisture in the refrigerant system. The most effective method is to use a two-stage vacuum pump. A high stage vacuum pump will remove all the moisture in the refrigerant system because it lowers the pressure in the system to a level at which the water will boil.

- e. Charge the system with the refrigerant.
- f. Run the system for approximately 6 hours.
- g. Make an acid test.
If the oil sample indicates acid, pump down the system and close the compressor service valve, drain the compressor of the oil and refill with new oil. Replace the drier.
- h. Run the refrigeration unit for an additional 6 hours and then carryout a new acid test. Repeat the above procedure until the system is free of acid.

7.2 COND. AND EVAP. FANS MOTOR

The condenser fan motor is a totally enclosed motor and is equipped with shielded ball bearings, which require no lubrication under normal service conditions.

The evaporator fan motors are totally enclosed motors and are equipped with shielded ball bearings, which require no lubrication under normal service conditions. It is recommended to check the bearings for noise and defects every ½ year, or before a long period of use.

7.3 COND. AND EVAP. FANS

If a motor or fan must be removed / dismantled from the unit for any reason, ensure that the motor or fan is relocated, to the same position.

7.4 FILTER-DRIER ASSEMBLY

A replaceable filter-drier is installed in the liquid line. It removes moisture and dust from the refrigerant while it is circulated.

TO REPLACE FILTER-DRIER IN THE R134a SYSTEM

If the moisture indicator shows a yellow color, or if the outlet side of the drier feels cooler than the inlet side, the drier should be changed.

- 1. Close the liquid line shutoff valve, and pump down the system until the suction pressure stabilizes at 0 bar. Remove all power to unit.
- 2. Remove drier from clamp, and un-solder the drier.

3. Remove caps from new drier and install immediately. (If the change of the driers is accomplished fast enough, there will be no need to purge air out of the lines.)
4. Using the flow directional arrow, install the new drier correctly into the liquid line.
5. Open liquid valve and the unit is ready to run again.

TO REPLACE DRIER IN THE R23 SYSTEM

If the moisture indicator shows a yellow color, or if the outlet side of the drier feels cooler than the inlet side, the drier should be changed.

The total refrigerant charge must be pumped into a tank that is approved for the R23 gas. (See instruction, Section 6.8.)

NOTE: Using the flow directional arrow, install the new drier correctly into the liquid line.

7.5 HIGH-PRESSURE SWITCH, COMPRESSOR

The pressure switches function automatically to open or close the compressor contactor coil circuit upon increase or decrease in discharge pressure.

All pressure switches are mounted on the "Schrader valve" adapter.

To replace the pressure switches, located on the discharge side of the compressors:

1. Switch off the unit.
2. Disconnect/cut wire to switch, loosen the pressure switch and quickly unscrew the pressure switch. The unit will not lose refrigerant, because the "Schrader valve" will close when the switch is disconnected.
3. Replace defective switch.
4. Connect electrical wires.

7.6 PRESSURE TRANSDUCERS.

Both refrigerant systems in the unit are designed with transducers on the high and low-pressure sides.

All four transducers are equipped with "Schrader valve" adapters.

To replace transducer:

1. Switch off the unit.
2. Disconnect/cut wire to the transducer, loosen and quickly unscrew the transducer. The unit will not lose refrigerant, because the "Schrader valve" will close when the transducer is disconnected.
3. Replace defective transducer.
4. Connect electrical wires.

7.7 THERMAL EXPANSION VALVE.

There are two expansion valves on the unit:

- 1 pc. for R134a/R23 heat exchanger,
- 1 pc. for R23 evaporator coil.

Both are technically the same and consist of three parts:

- a. The body, to which the inlet and outlet tubing is brazed.
- b. The cage/filter.
- c. The power element which is part of the body. The thermal sensing bulb, which is attached to the top of the power assembly by a capillary tube, allows the power element to be controlled by temperature changes in the bulb. In addition to this, a 1/4 in. copper tube connects the valve to the suction line, which serves as equalizer.

The thermal bulb is secured to a pre-selected point on the suction line and is positioned at 4 or 8 o'clock, by perforated metal straps. If, for any reason, these bulbs are removed from the suction line, care must be taken to ensure the bulbs are replaced correctly.

It is seldom that an expansion valve fails and even less often that it needs adjustment. Superheat is pre-set and should not need attention after installation.

THERMAL EXPANSION VALVE, R134a

The expansion valve is pre-set by the manufacturer to operate at 9°C superheat on max. capacity. No attempt should be made to adjust this setting. Non-compliance to this could cause a reduction in system capacity and may damage the compressor and void the warranty.

If, at initial start-up of the system, a particle of dirt does become lodged in the valve, it will be necessary to pump down the system and dismantle the valve cage/filter to remove the particle.

THERMAL EXPANSION VALVE, R23

The expansion valve is pre-set by the manufacturer to operate at 6°C superheat on max. capacity. No attempt should be made to adjust this setting. Non-compliance to this could cause a reduction in system capacity and may damage the compressor and void the warranty.

If valve fails, the total refrigerant charging must be pumped into an approved tank for R23 gas. (See instruction, section 6.8).

7.8 SAFETY RELIEF VALVE

There are four “safety relief valves” in the unit refrigerant system:

R134a SYSTEM

One in the system’s discharge line, to relieve the pressure in the high-pressure side, if the unit gets overcharged. (29.3 bar)

R23 SYSTEM

One in the system’s suction line, to relieve the pressure in the low-pressure side if the unit gets overcharged. (20.7 bar)

One in the system’s discharge line, to relieve the pressure in the high-pressure side, if the unit gets overcharged. (29.3 bar)

One on the buffer tank / high-pressure side, to relieve the pressure if the unit is overcharged. (29.3 bar)

The valves cannot be adjusted and if one of the valves fails, the total refrigerant charge must be removed from the system.

7.9 NON-RETURN VALVE

There are two “non-return valves” in the unit refrigerant system:

R134a SYSTEM

Two (2) are mounted in the discharge piping to compressors 1 & 2, to prevent the refrigerant from going back in to the compressor, when it stops.

If one of the valves fails, the total refrigerant charge must be removed from the system.

7.10 CRANKCASE PRESSURE REGULATOR, R23

For operation with high air temperature in the container room, a crankcase pressure regulator is mounted in the R23 system suction line, to protect compressor 3 motor against overload.

TO ADJUST REGULATOR

1. Connect service pressure gauge to the compressor suction valve “Schrader valve” adapter.
2. Start unit, (**NOTE.** Adjust with unit operating on defrost.)
3. Remove protection cap on crankcase pressure regulator.
4. With an Allen wrench turn the adjustment stem clockwise to raise or counter-clockwise to lower the valve setting. Correct setting is max. suction pressure 3.5 bar.
5. Replace protection cap on crankcase pressure regulator.

If valve fails, the total refrigerant charge must be pumped into an approved tank for R23 gas. (See instruction, section 6.8).

7.11 LIQUID INJECTION VALVE, COMPRESSORS R134a

The two liquid injection valves, compressors 1 and 2 are pre-set by the manufacturer (Copeland) to control that temperature on the compressor does not rise above approximately 90°C. Non-compliance to this could cause a reduction in system capacity and may damage the compressor and void the warranty.

TO REPLACE THE VALVE:

1. Close the shut off valve in the liquid line and pump down the system, until the suction pressure stabilizes between 0 and 0.1 bar. Remove all power to unit.
2. Slowly loosen bolts on the valve body to release any R134a that may be left in the system.
3. Replace defective valve.
4. Re-install new valve.
5. If the repair/exchange is completed within 5 minutes, purging the system for air will not be necessary because the refrigerant mixed in the compressor/evaporator coil will continue to boil off and create positive pressure in the system, which will prevent air from entering.
6. Open the liquid line shut off valve and the unit is ready to start again.

7. Check for leaks.

7.12 LIQUID INJECTION VALVE, COMPRESSOR R23

The liquid injection valve, compressor 3, is pre-set by the manufacturer (Copeland) to control that temperature on the compressor does not rise above approximately 90°C. Non-compliance to this could cause a reduction in system capacity and may damage the compressor and void the warranty.

If valve fails, the total refrigerant charge must be pumped into an approved tank for R23 gas.
(See instruction, section 6.8).

7.13 MAX. HOT GAS PRESSURE REGULATOR.

To prevent operating the system with too high of pressure during defrosts, a “max. hot gas pressure regulator” is mounted in the R23 hot gas piping, the valve opens for leading the pressure to the buffer tank.

TO ADJUST REGULATOR

1. Connect service pressure gauge to the compressor suction service valve.
2. Start unit. (**NOTE:** Can only be adjusted when system is in defrost.)
3. Remove protection cap on the pressure regulator.
4. With an Allen wrench turn the adjustment stem clockwise to raise or counter-clockwise to lower the valve setting.
Correct setting is max. pressure at 19 bar.
5. Replace protection cap on pressure regulator.

If valve fails, the total refrigerant charge must be pumped into an approved tank for R23 gas.
(See instruction, section 6.8)

7.14 LIQUID SOLENOID VALVE, R134a

The solenoid valve (NC) in the R134a system is mounted in the liquid line; the valve operates on a signal from the controller. When the solenoid coil is energized, it diverts refrigerant to the expansion valve.

TO REPLACE OR REPAIR VALVE.

1. Close the liquid line shut off valve, and pump down the system until the suction pressure stabilizes between 0 and 0.1 bar. (The valve must be open.) Remove all power to unit.
2. Remove cap and coil.
3. Slowly loosen bolts on the solenoid valve body to release any refrigerant that may be left in the lines.
4. Remove enclosing tube slowly, check for foreign material in the valve.
5. Replace defective parts.
6. Re-install all valve parts.
7. If the repair/exchange is completed within 5 minutes, purging the system for air will not be necessary because the refrigerant mixed in the compressor/evaporator coil will continue to boil off and create positive pressure in the system, which will prevent air from entering.
8. Open the liquid line shut off valve and the unit is ready to start again.
9. Check for leaks.

7.15 HOT GAS SOLENOID VALVE

The solenoid valve (NC) in the R23 hot gas system is mounted in the hot gas piping to the evaporator coil and the drain piping.

The valve operates from a signal from the controller. When the solenoid coil is energized, it diverts hot gas to the evaporator coil.

If the valve fails, the total refrigerant charge must be pumped into an approved tank for R23 gas.
(See instruction, section 6.8).

7.16 HEATED VACUUM VALVE

The vacuum valve draws outside air into the container to prevent the container from developing negative atmospheric pressure as the cargo temperature decreases toward -70°C. This is activated during pulldown as well as when there is a quick temperature change within the container for example during a Door Opening or Defrost Operation.

It is extremely important to check the vacuum pipe opening, to make sure that the pipe is not blocked by ice or snow. The frequency of this check is dependent on the operation conditions of the unit. We suggest that this check should be performed on a weekly basis and possibly more frequently if there are a number of Door Openings.

If there is a failure with the vacuum valve heater, the unit 2 alarm light will be activated along with the horn. Note, the display will not show an alarm code. The alarm will occur if the vacuum valve heater circuit breaker is disengaged or if there is a loss of power to the vacuum valve heater. Please note that a 12VDC (battery) must be connected to the alarm circuit for alarms to function.

7.17 SERVICING SCHEDULE

	Daily or Weekly	Initial 50 Hours	Every 250 Hours	Every 500 Hours	Every 1000 Hours	Every 2000 Hours
REFRIGERATION SYSTEM (NMF SERIES)						
Check Compressor Oil Level / add if needed		X	X			
Check and clean Condenser Coils		X	X			
Check Moisture Indicators				X		
Check Refrigerant Levels				X		
Check Reefer for unusual noises	X		X			
Inspect Reefer Unit for damaged, loose, or broken parts, missing bolts			X			
Check condition of mounting bolts		X	X			
Check Vacuum Valve is clear	X					

In addition to the above checklist, the normal Pre-Trip Inspection Form should also be completed every 2 months.

SECTION 8. TROUBLE SHOOTING

8.1 GENERAL INFORMATION

Several components are incorporated in the unit to assist the service engineer to find the cause of problems, concerning the operation and efficiency of the unit.

LED's on the display panel indicate which cycle the micro-processor controller is calling for and should be used in conjunction with the pressure gauges to determine whether certain cycles are operating.

NOTE: It is recommended to initiate the test after all repairs. The alarm light on the display panel will be lit until the failure is repaired.

There are two alarm conditions that will not show an alarm code on the display. Please note that a 12VDC (battery) must be connected to the alarm circuit for alarms to function.

1. Power Loss – In the event that the unit switch is set to “ON” and power is not supplied to the transformer the alarm lamp and horn will activate. This could be caused by a complete power loss or the main circuit breaker is disengaged.
2. Heated Vacuum Valve - If there is a failure with the vacuum valve heater, the unit 2 alarm light will be activated along with the horn. The alarm will occur if the vacuum valve heater circuit breaker is disengaged or if there is a loss of power to the vacuum valve heater.

All other alarms will display a code. Please see Alarm Chart below.

8.2 ALARM CHART

“ALARM“ LAMP LIGHT ON			
GO TO “ALARM” IN MAIN MENU, PRESS (→) FOR ENTER. THE DISPLAY SHOWS ACTIVE ALARM CODE.			
SCROLL, PRESS (↓) OR (↑)PRESS (→) FOR CANCEL ESC. PRESS (←)			
Alarm Name:	Alarm #	Description	Corrective Action
Return air sensor out of range	A01	The sensor has an open (999.9°C) or short circuit (-99.9°C)	Replace defective sensor.
Supply air sensor out of range	A02	The sensor has an open (999.9°C) or short circuit (-99.9°C)	Replace defective sensor.
Defrost sensor out of range	A03	The sensor has an open (999.9°C) or short circuit (-99.9°C)	Replace defective sensor.
Cargo sensor out of range	A04	The sensor has an open (999.9°C) or short circuit (-99.9°C) and if configuration parameter is set to “ON”	Replace defective sensor.
Compr 1 sensor out of range	A06	The sensor has an open (999.9°C) or short circuit (-99.9°C)	Replace defective sensor.
Compr 2 sensor out of range	A07	The sensor has an open (999.9°C) or short circuit (-99.9°C)	Replace defective sensor.
Compr 3 sensor out of range	A08	The sensor has an open (999.9°C) or short circuit (-99.9°C)	Replace defective sensor.
R23 low press out of range	A10	Pressure Transducer, R23 low-pressure, has an open (14.5bar) or short circuit (-2.91bar)	Replace defective transducer.
R134a low press out of range	A11	Pressure transducer, R134a low-pressure has an open (14.5 bar) or short circuit (-2.91bar)	Replace defective transducer.
R23 high press out of range	A12	Pressure transducer, R23 high-pressure, has an open (40 bar) or short circuit (-4.82 bar)	Replace defective transducer.
R134a high press out of range	A13	Pressure transducer, R134a high-pressure has an open (40 bar) or short circuit (-4.82 bar)	Replace defective transducer.
Return air sensors out of range	A14	The check is performed by the secondary system. If the difference between System 1 Return Sensor and System 2 Return Sensor is greater than 6.5°C, the alarm will engage	Replace return air sensor
Secondary system return and supply sensors out of range	A15	The check is performed by the secondary system. The system is checking its own Return and Supply Sensor to ensure that they are within +/-5.0°C on average over a 15 minute period.	Replace return air sensor

Ambient temp sensor out of range	A16	The sensor has an open (999.9°C) or short circuit (-99.9°C)	Replace defective sensor.
Reference error. Shutdown	A17	Internal controller error	Replace defective MPC3 Controller.
Evap temp too low	A18	If the controller calls for a defrost less than 30 minutes after last defrost end. (the delta T between the return air and the defrost probe is too large)	Check evaporator fan motor. Check airflow. Check if fins at evaporator coil are bent. Check door to container is closed. Check defrost and return sensors for correct reading.
Cargo temp too low ** Applicable only when cargo probe is part of system	A19	The cargo sensor alarm will activate if the configuration parameter is set to "ON" and a Cargo sensor is mounted, and after the temperature has been more than 5°C out of range below Setpoint for 2 minutes. This alarm will not be activated if the set point is lower than -60°C	Check hot gas system. Check evaporator fan motor. Check air flow. Check container door is closed.
Cargo temp too high ** Applicable only when cargo probe is part of system	A20	The cargo sensor alarm will activate if the configuration parameter is set to "ON" and a Cargo sensor is mounted, and after the temperature has been more than 5°C out of range above Setpoint for 2 minutes. This alarm will not be activated if the set point is lower than -60°C	Check refrigerant gas. Check TX valve. Check evaporator fan motor. Check air flow. Check compressor. Check if condenser is dirty. Check condenser fan motor. Check container door is closed.
Comp #1 temp too high	A22	Compressor 1, discharge line temp above 120°C	Repair or replace defective sensor.
		Defective refrigerant system	Check R134a refrigerant charge. (Sight glass)
		Too high condensing temperature. (Max. 30°C above ambient)	Clean condenser, check condenser fan motor and fan.
Comp #2 temp too high	A23	Defect liquid injection valve.	Repair or replace defective part.
		Compressor 2, discharge line temp above 120°C	Repair or replace defective sensor.
		Defective refrigerant system	Check R134a refrigerant charge. (Sight glass)
Comp #3 temp too high.	A24	Too high condensing temperature. (Max. 30°C above ambient)	Clean condenser, check condenser fan motor and fan.
		Defective liquid injection valve	Repair or replace defective part.
		Compressor 3, discharge line temp above 125°C.	Repair or replace defective sensor.
Drop of temperature is slow.	A26	Defective refrigerant system.	Check R23 refrigerant charge. (Sight glass)
		Too high condensing temperature. (Heat exchanger R134a/R23 not operating optimally.)	Check R134a refrigerant charge. (Sight glass)
Setpoint differ sys1/sys2	A28	The alarm is activated when the return air sensor is within 5°C of the set point AND there is a decrease in the average drop in temperature measured at the return air over a period of 50 minutes.	Check container door is closed. Check refrigerant system. Reset evap fan motors.
No response from other unit	A29	If the set points of the (2) systems are more than 1°C out of sync with each other then alarm will activate	Adjust the set point temperature to within 1°C of each other, automatically clears
Evap fan current too low	A30	Unit will display alarm if only one unit is powered ON for more than 3 minutes	Turn ON the second unit, automatically clears, or allow to operate as is, if necessary.
Phase direction problem (Controller not able to "set" phase direction)	A31	The fan motor is using too little power.	Check if relay is switched on. Check output from controller.
		Missing phase from main power.	Check power in all 3 phases.
R23 High-pressure cut-out.	A33	Defective phase sensor relay.	Repair or replace defective relay.
		Defective refrigerant R134a system.	
		Defective compressor R134a system.	Check R134a compressors.
R134a High-pressure cut-out	A34	Condenser fan is not running	Check condenser motor.
		Defective refrigerant system	Check R23 refrigerant system.
		Too high condensing temperature. (Max. 30°C above ambient)	Clean condenser, check condenser fan motor and fan.
		Condenser fan is not running	Check condenser motor.
		Defective refrigerant system	Check 134a refrigerant system.

R23 Suction pressure low	A35	Suction pressure R23 too low <0 bar	Check R23 charge Check R23 TX valve Check evap fan motor Check air circulation in container
R134a Suction pressure low	A36	Suction pressure R134a too low < -0,5 bar	Check R134a charge Check R134a TX valve Check R23 system for fault. Check air circulation in container
Evap fan motor temp too high.	A37	Evaporator motor temp above 65°C (If the motor operated too long with high box temperature (+°C), the motor will be overheated)	Check motor condition (run free) and try to restart.
Evap fan motor start fail	A38	Evaporator motor has failed to start, motor may be frozen/stuck in fan blade	Check motor condition (run free) and try to restart.
Fail on sec. sys no change	A39	An error occurred on the primary system, but changeover to the secondary system cannot occur.	Check secondary system is ON. Check alarm code on secondary system. Check communication cable connections.
Auto test error, amps too low	A40	Current of one of the tested parts is too low	Check amps on the faulty part with an ammeter. Repair or replace defective part.
Auto test error, amps too high	A41	Current of one of the tested parts is too high	Check amps on the faulty part with an ammeter. Repair or replace defective part.
Auto test error, delta amps too high	A42	The difference in current of one of the tested parts is too high	Check amps on the faulty part with an ammeter. Repair or replace defective part.
Door open too long	A43	The container door has been open longer than the time allowed based on alarm setting	Close container door
Generator power drop	A44	Power supply to system has dropped below required voltage/frequency	Check power supply output
Emergency stop activated	A46	Emergency switch in container is activated	Check for person in container. Reset Emergency switch. Defective Emergency switch.

NOTE: Alarms A28, A29 and A39 are low level alarms. For all other alarm codes listed above, the Controller software will determine to switch to the secondary unit, making it the primary unit after a failure occurs.

MESSAGE INFORMATION IN DISPLAY.

(To see message in display, "Remove message" must be set to "OFF" in Controller "Switch setting" menu.)

DISPLAY SHOWS:		Description	Action
Comp #1 temp too high	M04	Compressor #1 discharge line temp above 120°C	Info only
Comp #2 temp too high	M05	Compressor #2 discharge line temp above 120°C	Info only
Comp #3 temp too high	M06	Compressor #3 discharge line temp above 120°C	Info only
Evap fan motor temp too high	M08	Evaporator motor temp above 65°C	Unit shutdown
R23 High-pressure	M10	R23 high-pressure higher than 27 bar	After 5 times, the Unit stops, an A33 alarm will be activated
R23 Low-pressure	M12	R23 low-pressure lower than 0.2bar	Info only
R134a Low-pressure	M13	R134a low-pressure lower than -0.4bar	Info only
Door open. (Option)	M18	Container door open	Unit shutdown
Emergency stop activated	M19	Emergency switch in container is activated	See Alarm code A46
Phase direction test	M20	Phase direction test run (Max. 25 sec. after main power ON)	Direction, 0 = test Run direction, 1= PC, R1 Run direction, 2= PC, R2
Phase direction test missing	M21	Phase direction test errors	Unit shutdown

8.3 UNIT INFORMATION

ELECTRICAL

Electrical All data are approx. and based on 460volt/60 Hz	
Input power	400/460 volts +/-10% 3 phase 50/60 Hz +/-5%
Compressor Max. Operating Current (each)	25.0 Amps
Compressor Displacement (each)	20.6 m ³ /hr
Compressor HP (each)	6
Condenser fan motor	1200 RPM. ¾ HP
Evaporator fan motors (each)	1120 RPM, rated output 0.25kW

REFRIGERANT

Refrigerant System	
System charging R134a	3.9 kg
System charging R23	2.1 kg
Compressor 1. Oil charge	1.9 Liter
Compressor 2. Oil charge	1.9 Liter
Compressor3. Oil charge	1.9 Liter
High-pressure switch, R134a system (cannot be adjusted)	Cut-out approx. 24.1 bar +/-0.7 bar (350 psi) Cut-in approx. 17.2 bar +/-0.7 bar (250 psi)
High-pressure switch, R23 system (Cannot be adjusted)	Cut-out approx. 27.5 bar +/-0.7 bar (400 psi) Cut-in approx. 20.7 bar +/-0.7 bar (300 psi)
Hot gas Max. pressure regulator R23 system	Set to max. Pressure at 10 bar
Crankcase pressure regulator R23 system	Set to suction pressure at max. 3 bar
Safety relief valve, R134a High-pressure (Cannot be adjusted)	29.3 bar (425 psi)
Safety relief valve, R134a Low-pressure (Cannot be adjusted)	20.7 bar (300 psi)
Safety relief valve, R23 High-pressure/ buffer tank. (Cannot be adjusted)	29.3 bar (425 psi)
Safety relief valve, R23 Low-pressure (Cannot be adjusted)	20.7 bar (300 psi)

SECTION 9. SERVICE PARTS

- 9.1 Unit Front
- 9.2 Condenser Section
- 9.3 Evaporator Section (2 per system)
- 9.4 Electrical Box Unit 1 (top)
- 9.5 Electrical Box Unit 2 (bottom)
- 9.6 Changeover Box
- 9.7 MPC3 Display
- 9.8 Kit Spare Parts (Optional)

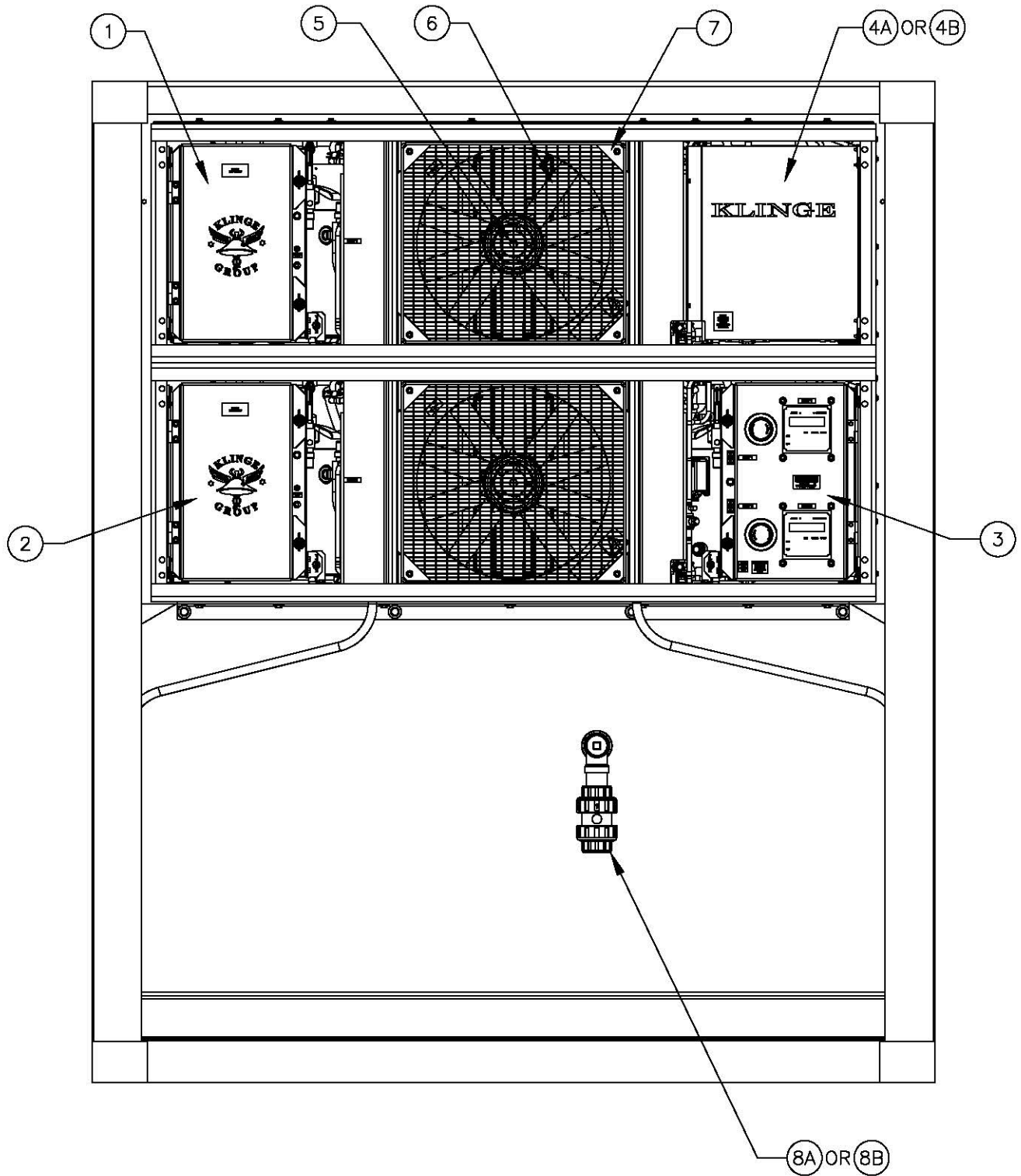

SECTION 9.1

UNIT FRONT

SECTION 9.1 UNIT FRONT

ITEM	PART NO.	DESCRIPTION	QTY.
1	360-16620-03	BOX ELECTRICAL COMPLETE SYSTEM 1 NMF-372	1
2	360-16620-04	BOX ELECTRICAL COMPLETE SYSTEM 2 NMF-372	1
3	360-17774-01	BOX CHANGEOVER COMPLETE	1
4A	360-16691-01	PANEL ACCESS RIGHT NMF (Standard)	1
4B	360-16917-01	KIT SPARE PARTS NMF-372 (Optional)	1
5	360-16572-00	MOTOR CONDENSER NMF-371	2
6	K26-25272-01	FAN 21.85 DIA 7/8IN BORE 10 BLADE 35° PITCH PUSH	2
7	360-16773-00	GRILL RECTANGLE 30 X 10	2
8A	360-18407-01	KIT VACUUM VALVE W/HEATER (ULT wall container STANDARD)	1
8B	360-18407-00	KIT VACUUM VALVE W/HEATER (ISO wall container OPTIONAL)	1

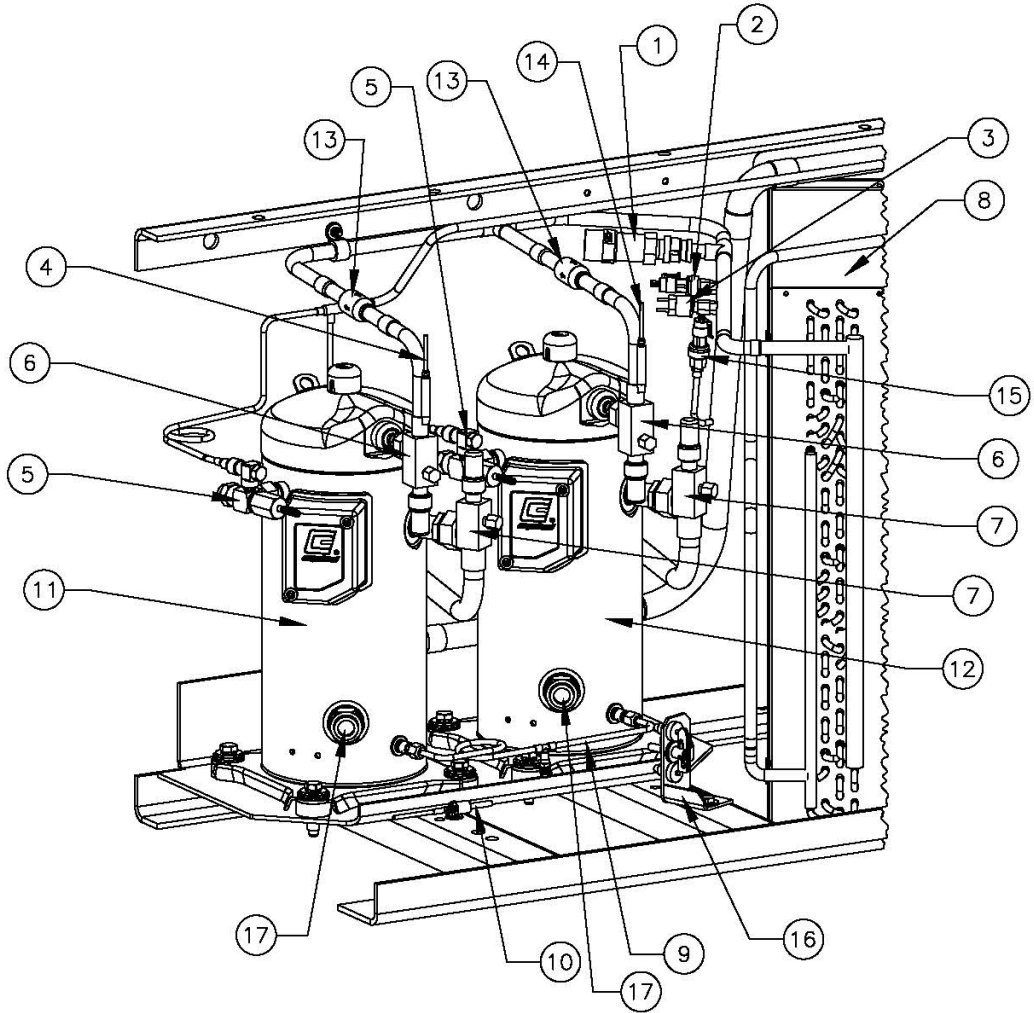

SECTION 9.2A

**CONDENSER SECTION LH
(R134a Compressor side 2 per system)**

SECTION 9.2A CONDENSER SECTION LH (R134a Compressor side 2 per system)

ITEM	PART NO.	DESCRIPTION	QTY.
1	K22-07028-01	VALVE RELIEF (425 PSIG)	1
2	K25-26810-00	TRANSDUCER HIGH PRESSURE	1
3	360-18463-00	CABLE HIGH-PRESSURE SWITCH R134A	1
4	360-16509-25	PROBE ASSEMBLY COMPRESSOR 1	1
5	K15-00042-13	KIT VALVE DTC DISCHARGE TEMPERATURE CONTROL	2
6	K22-06970-00	VALVE ROTALOCK 1-14 X 5/8C	2
7	K22-06910-00	VALVE ROTALOCK 1-1/4-12X7/8C	2
8	K26-25217-00	COIL CONDENSER LH R134A	1
9	360-16517-01	TUBE COMPRESSOR SHARED OIL LINE	1
10	360-16509-20	PROBE ASSEMBLY AMBIENT AIR	1
11	360-16581-01	COMPRESSOR 1 R134A	1
12	360-16581-02	COMPRESSOR 2 R134A	1
13	K26-58023-30	CHECK VALVE 5/8C X 5/8C	2
14	360-16509-26	PROBE ASSEMBLY COMPRESSOR 2	1
15	K25-26809-00	TRANSDUCER LOW PRESSURE	1
16	360-14799-03	BRACKET BABY ANTI-LUCE M8	1
17	K15-00042-17	SIGHT GLASS	2

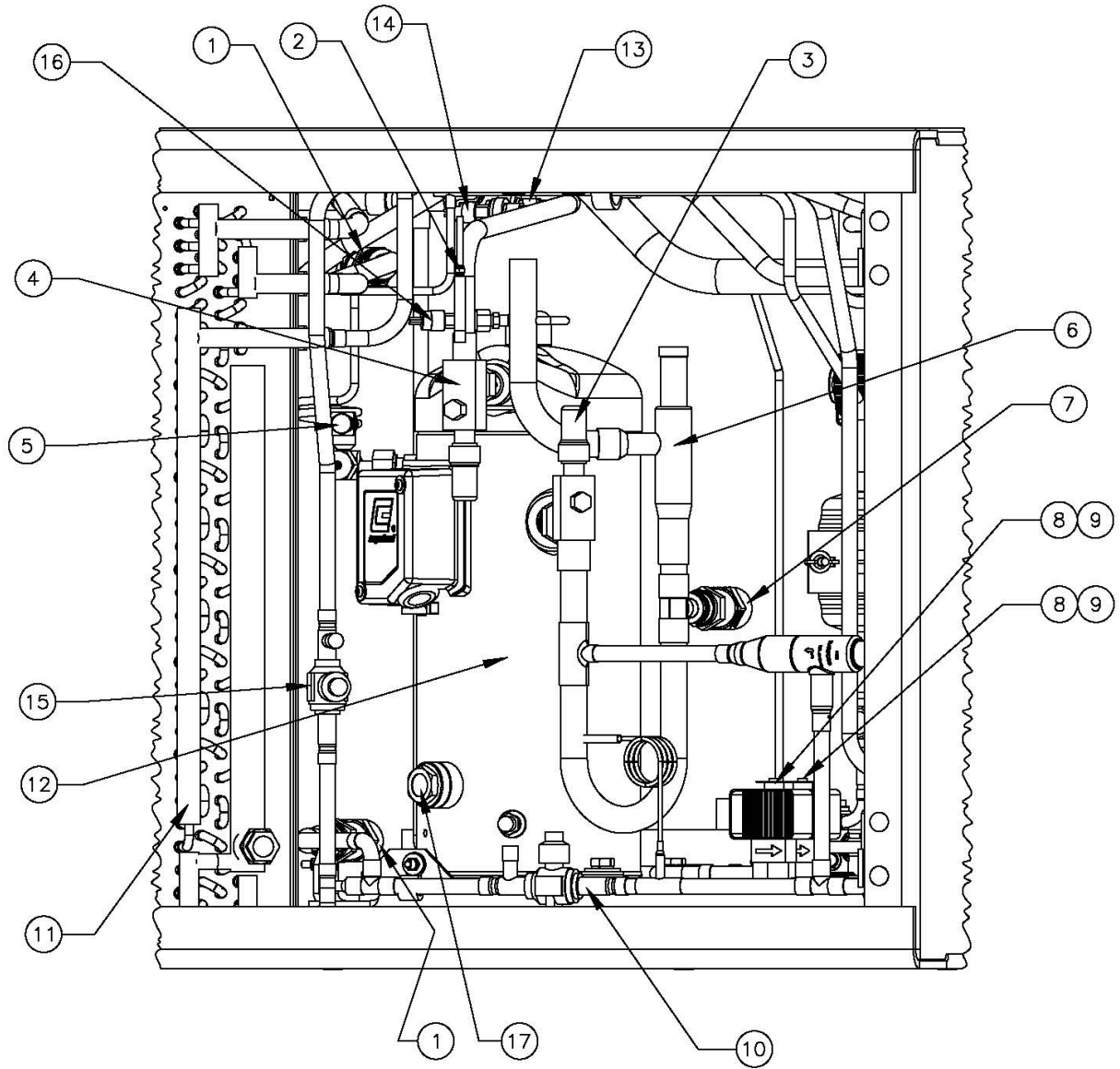

SECTION 9.2B

**CONDENSER SECTION RH
(R23 Compressor side 2 per system)**

SECTION 9.2B CONDENSER SECTION RH (R23 Compressor side 2 per system)

ITEM	PART NO.	DESCRIPTION	QTY.
1	K22-07028-01	VALVE RELIEF (425 PSIG)	2
2	360-16509-27	PROBE ASSEMBLY COMPRESSOR 3	1
3	K22-06910-00	VALVE ROTALOCK 1-1/4-12X7/8C	1
4	K22-06970-00	VALVE ROTALOCK 1-14X5/8C	1
5	K15-00042-13	KIT VALVE DTC DISCHARGE TEMPERATURE CONTROL	1
6	K22-07026-00	PRESSURE REGULATOR CRANKCASE SUCTION LINE	1
7	K22-07028-00	VALVE RELIEF (300 PSIG)	1
8	360-17300-04	CABLE HOT GAS SOLENOID	2
9	K25-26089-01	VALVE SOLENOID ½ ODF NORMALLY CLOSED	2
10	K22-07030-03	VALVE SHUT-OFF ½C X ½C	1
11	K26-25218-00	COIL CONDENSER RH	1
12	360-16581-03	COMPRESSOR 3 R23	1
13	360-16405-20	CABLE HIGH PRESSURE SWITCH R23	1
14	K25-26810-00	TRANSDUCER HIGH PRESSURE	1
15	K22-07030-03	VALVE SHUT-OFF 1/2C	1
16	K25-26809-00	TRANSDUCER LOW PRESSURE	1
17	K15-00042-17	SIGHT GLASS	1

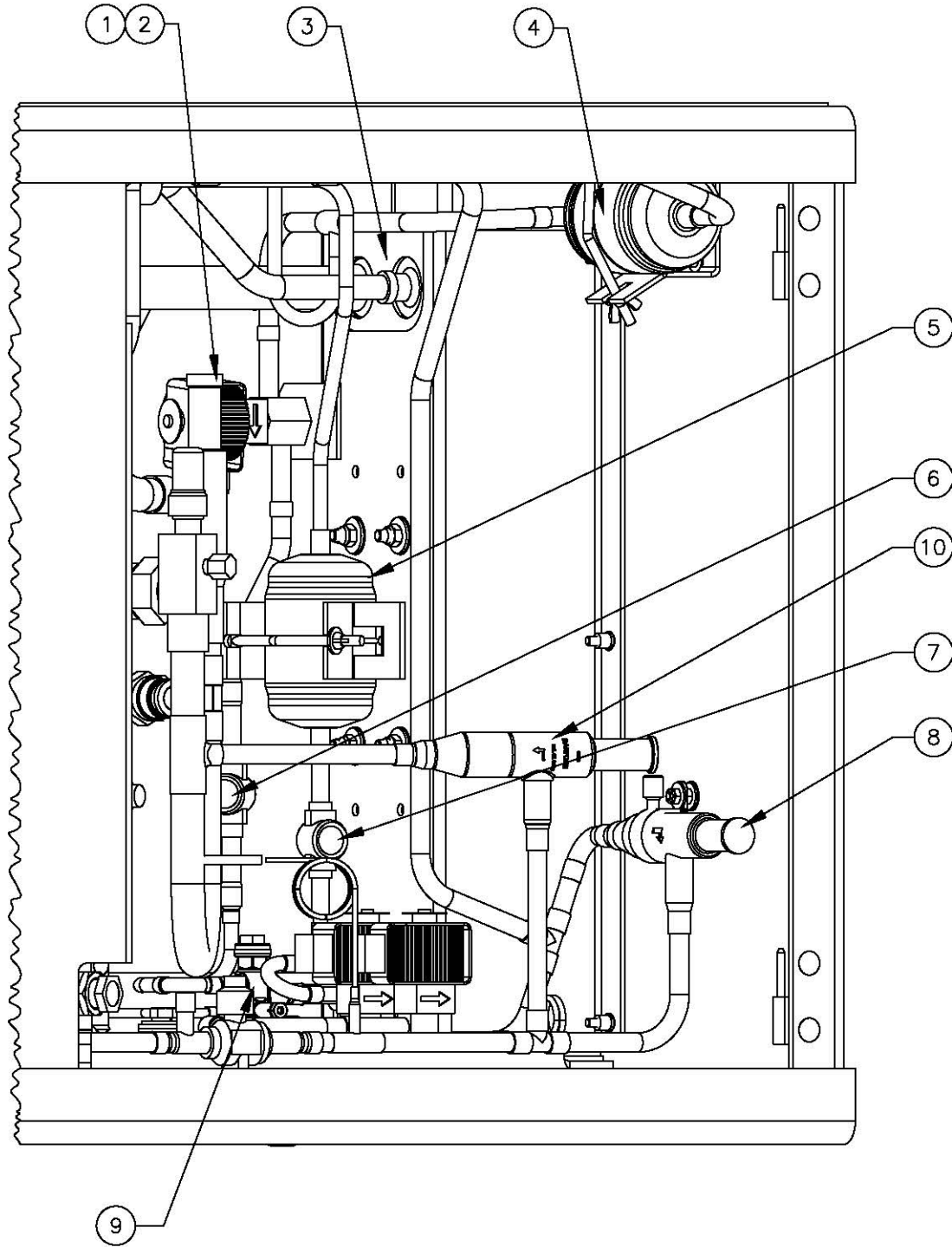

SECTION 9.2C

**CONDENSER SECTION RH
(R23 Compressor side 2 per system)**

SECTION 9.2C CONDENSER SECTION RH (R23 Compressor side 2 per system)

ITEM	PART NO.	DESCRIPTION	QTY.
1	360-17300-04	CABLE LIQUID SOLENOID	1
2	K25-26089-01	VALVE SOLENOID ½ ODF NORMALLY CLOSED	1
3	K26-25220-00	HEAT EXCHANGER CONDENSER R23/EVAPORATOR R134A	1
4	K26-10795-01	FILTER DRIER ½ C	1
5	K26-25215-00	FILTER DRIER 3/8 C	1
6	K26-25216-00	INDICATOR MOISTURE ½ C	1
7	K26-25116-01	INDICATOR MOISTURE 3/8 C	1
8	K22-07027-00	PRESSURE REGULATOR CONDENSING ½ C X ½ C	1
9	K25-26975-00	VALVE TX 3 TON R-134A	1
10	K22-07040-00	VALVE PRESS REG CPR 0.2-6.0 BAR 1/2 C	1

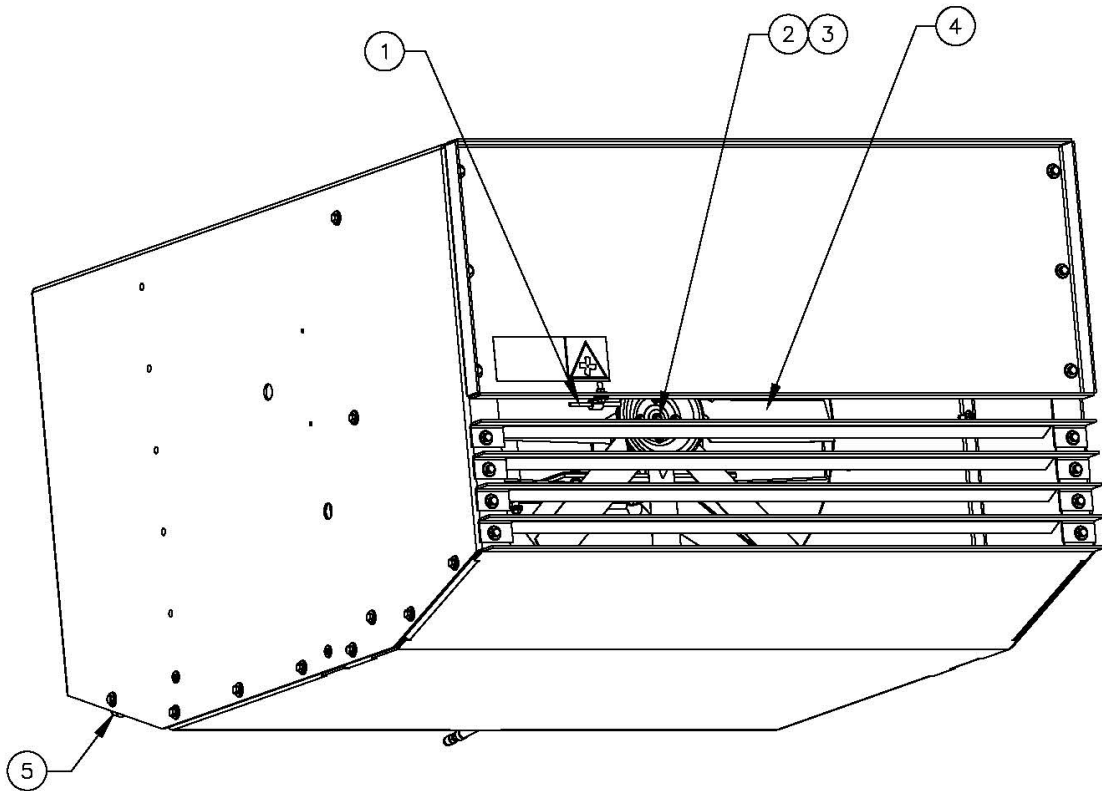

NOTE: SYSTEM 1 SHOWN.
ITEM 5 IN MIRRORED LOCATION ON SYSTEM 2

SECTION 9.3A

EVAPORATOR SECTION
(fan and probes 2 per system)

SECTION 9.3A EVAPORATOR SECTION (fan and probes 2 per system)

ITEM	PART NO.	DESCRIPTION	QTY.
1	360-16509-39	PROBE SUPPLY AIR	1
2	360-16743-15	MOTOR ASSEMBLY EVAPORATOR	1
3	360-16509-41	PROBE MOTOR	1
4	K26-25230-00	FAN 21.65"	1
5	360-16509-40	PROBE RETURN AIR (Inside Evaporator Wrapper)	1

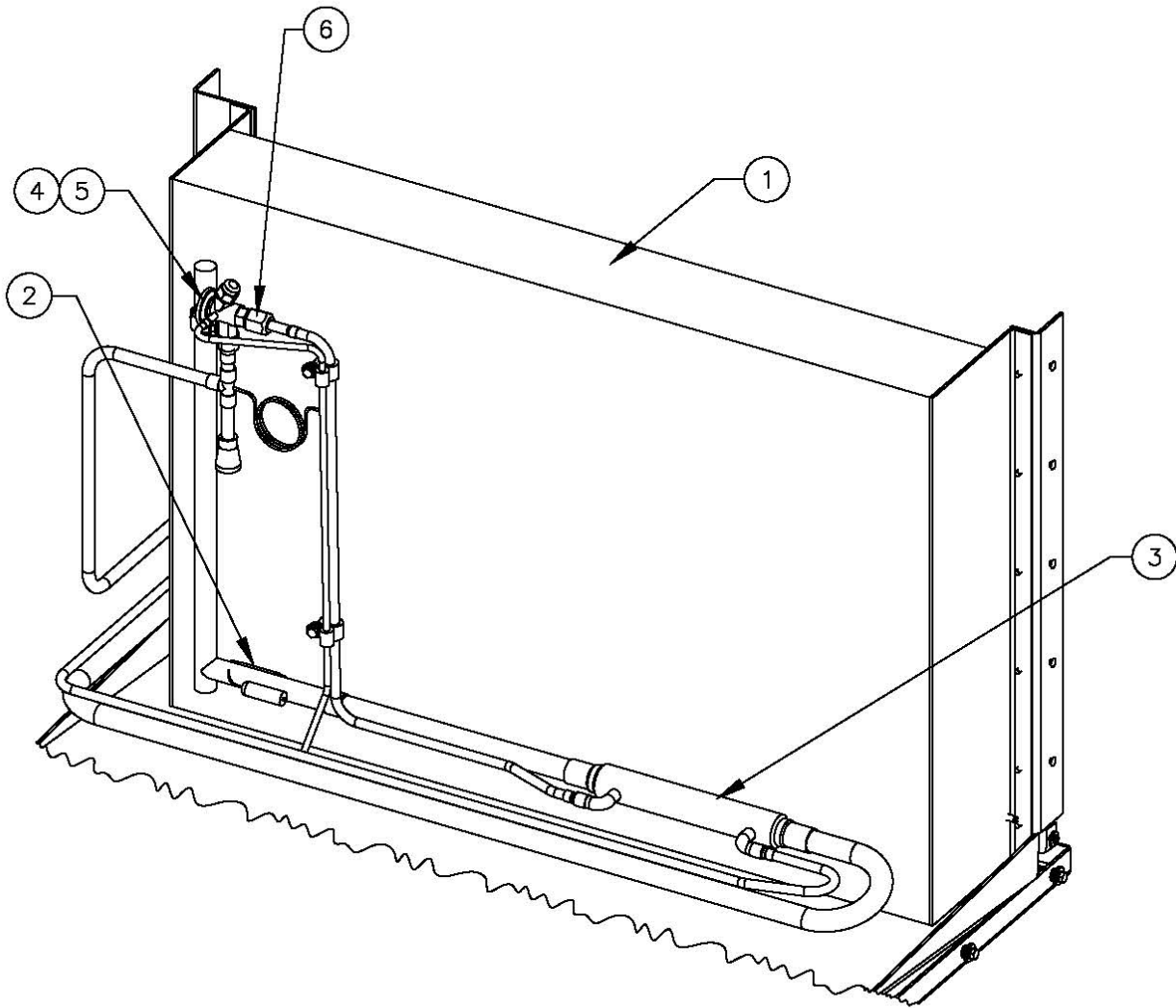

SECTION 9.3B
EVAPORATOR SECTION
(piping 2 per system)

SECTION 9.3B EVAPORATOR SECTION (piping 2 per system)

ITEM	PART NO.	DESCRIPTION	QTY.
1	K26-25229-00	COIL EVAPORATOR	1
2	360-16509-38	PROBE DEFROST	1
3	K26-17451-01	HEAT EXCHANGER 7/8 C X 1/2 C 11" LG	1
4	K25-25728-00	VALVE THERMAL EXPANSION R23	1
5	K25-25729-00	ORIFICE TX VALVE	1
6	K25-26777-02	ADAPTER SOLDER TX VALVE	1

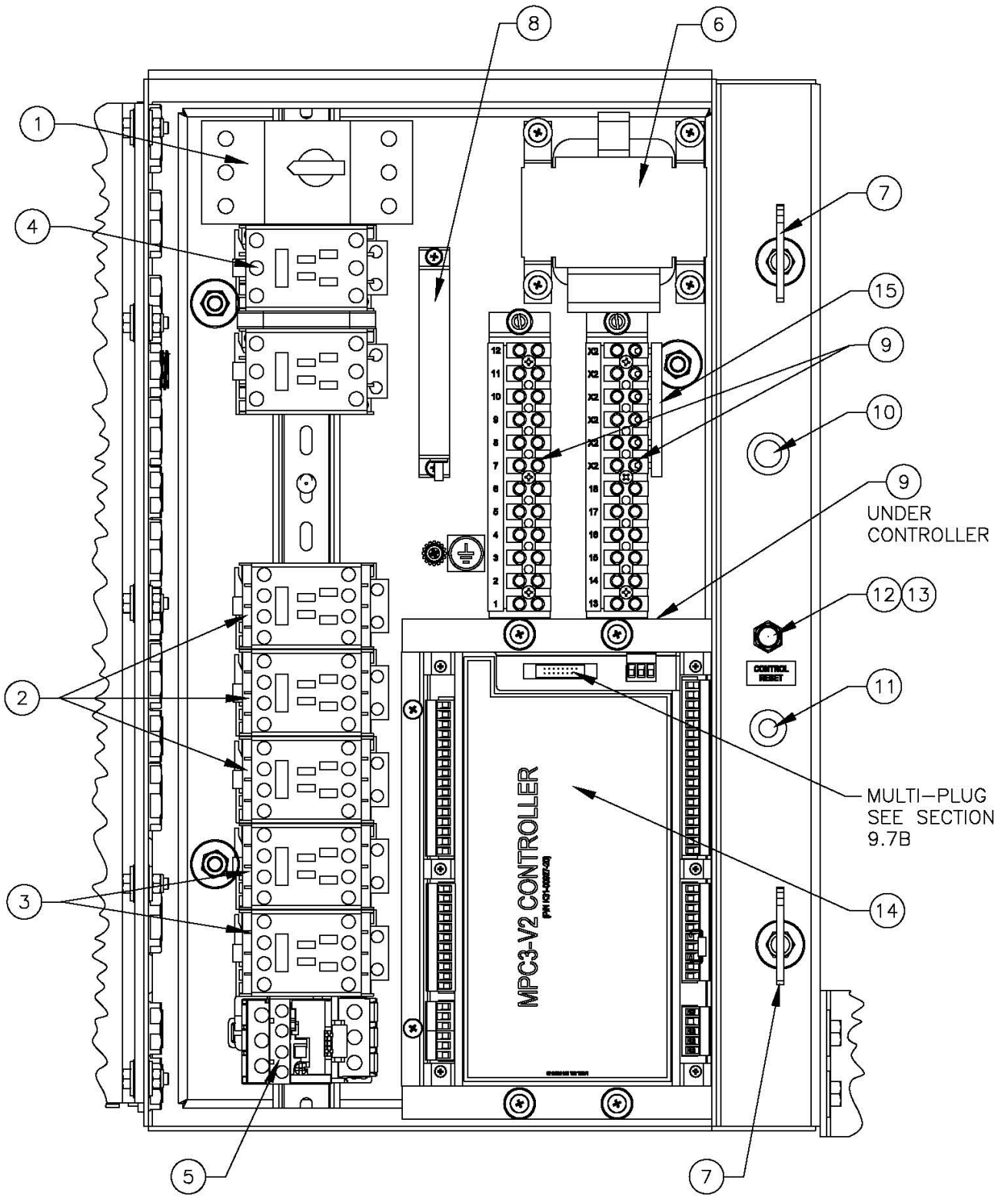

SECTION 9.4

**ELECTRICAL BOX
UNIT 1 (Top)**

SECTION 9.4 ELECTRICAL BOX UNIT 1 (Top)

ITEM	PART NO.	DESCRIPTION	QTY.
1	K24-22439-00	CIRCUIT BREAKER IEC 3P 23-32A	1
2	K24-58160-05	CONTACTOR CI25 29V/60HZ	3
3	K24-58160-03	CONTACTOR CI12 29V/60HZ	2
4	K24-22315-30	CONTACTOR REVERSING 30A 6P 24.29VAC 50/60HZ	1
5	K24-22268-00	RELAY OVERLOAD 3P 1.8-2.8 BASE	1
6	K25-26741-00	TRANSFORMER 480/28-4.6A/24-1A/20-1A 166VA	1
7	K21-16313-00	FASTENER BABY ANTI-LUCE M8 X 1.25	2
8	K25-26743-20	CURRENT SENSING TRANSFORMER 20A 3P	1
9	K25-26488-12	BLOCK TERMINAL STRIP 12P 45A	3
10	K28-10936-05	PLUG SEAL POLY FLUSH .50 HOLE	1
11	K28-10936-03	PLUG SEAL POLY FLUSH .38 HOLE	1
12	K24-20565-00	CIRCUIT BREAKER 8A 1P	1
13	K24-18164-00	BOOT CIRCUIT BREAKER 3/8-27 THD CLEAR	1
14	K31-00927-20	CONTROLLER MPC3 LABELLED	1
15	K25-26550-06	JUMPER TERMINAL STRIP 8-18 GA 0.47 CENTERS	1

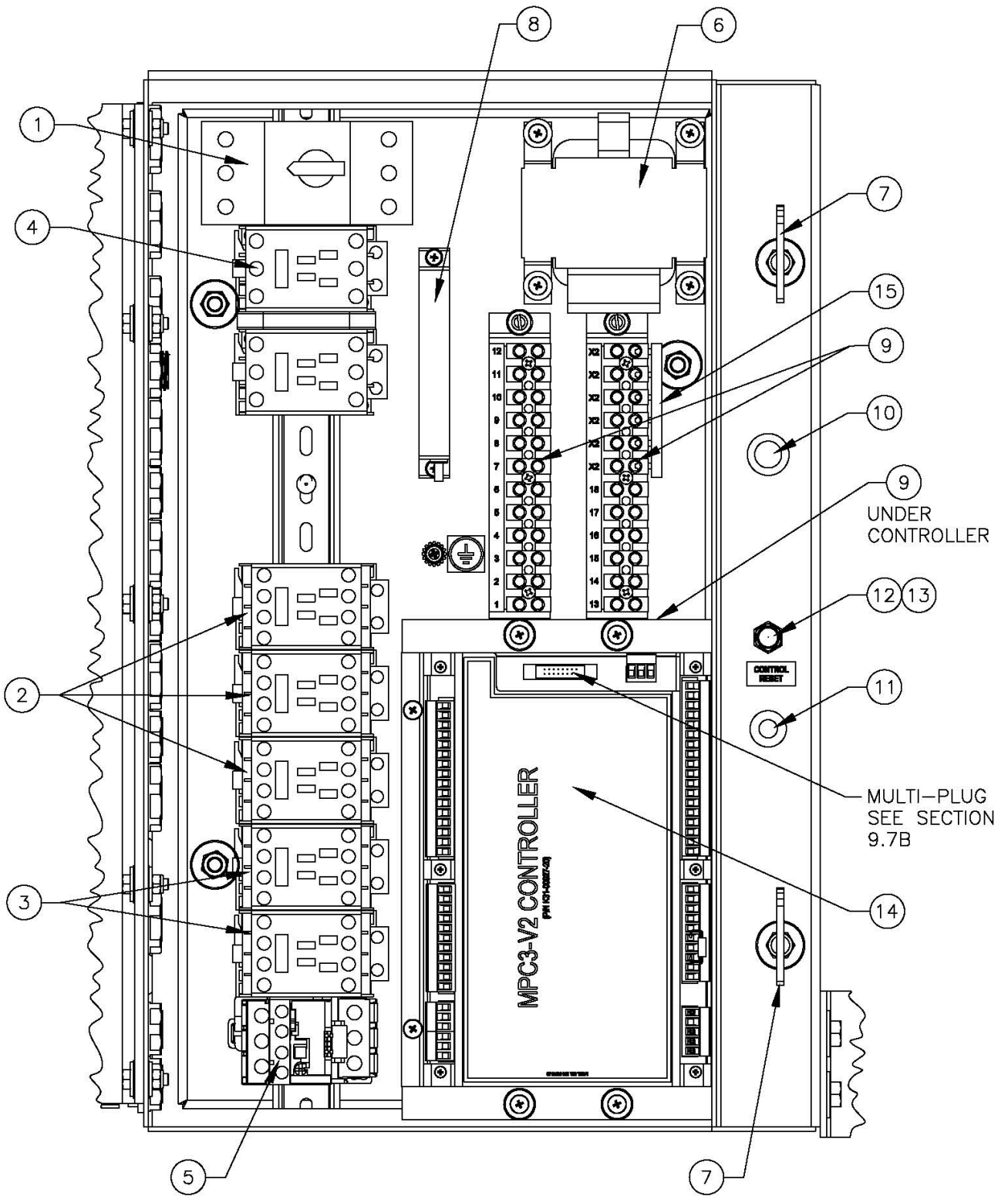

SECTION 9.5

ELECTRICAL BOX

UNIT 2 (Bottom)

SECTION 9.5 ELECTRICAL BOX UNIT 2 (BOTTOM)

ITEM	PART NO.	DESCRIPTION	QTY.
1	K24-22439-00	CIRCUIT BREAKER IEC 3P 23-32A	1
2	K24-58160-05	CONTACTOR CI25 29V/60HZ	3
3	K24-58160-03	CONTACTOR CI12 29V/60HZ	2
4	K24-22315-30	CONTACTOR REVERSING 30A 6P 24.29VAC 50/60HZ	1
5	K24-22268-00	RELAY OVERLOAD 3P 1.8-2.8 BASE	1
6	K25-26741-00	TRANSFORMER 480/28-4.6A/24-1A/20-1A 166VA	1
7	K21-16313-00	FASTENER BABY ANTI-LUCE M8 X 1.25	2
8	K25-26743-20	CURRENT SENSING TRANSFORMER 20A 3P	1
9	K25-26488-12	BLOCK TERMINAL STRIP 12P 45A	3
10	K28-10936-05	PLUG SEAL POLY FLUSH .50 HOLE	1
11	K28-10936-03	PLUG SEAL POLY FLUSH .38 HOLE	1
12	K24-20565-00	CIRCUIT BREAKER 8A 1P	1
13	K24-18164-00	BOOT CIRCUIT BREAKER 3/8-27 THD CLEAR	1
14	K31-00927-20	CONTROLLER MPC3 LABELLED	1
15	K25-26550-06	JUMPER TERMINAL STRIP 8-18 GA 6 POLE 0.47 CENTERS	1

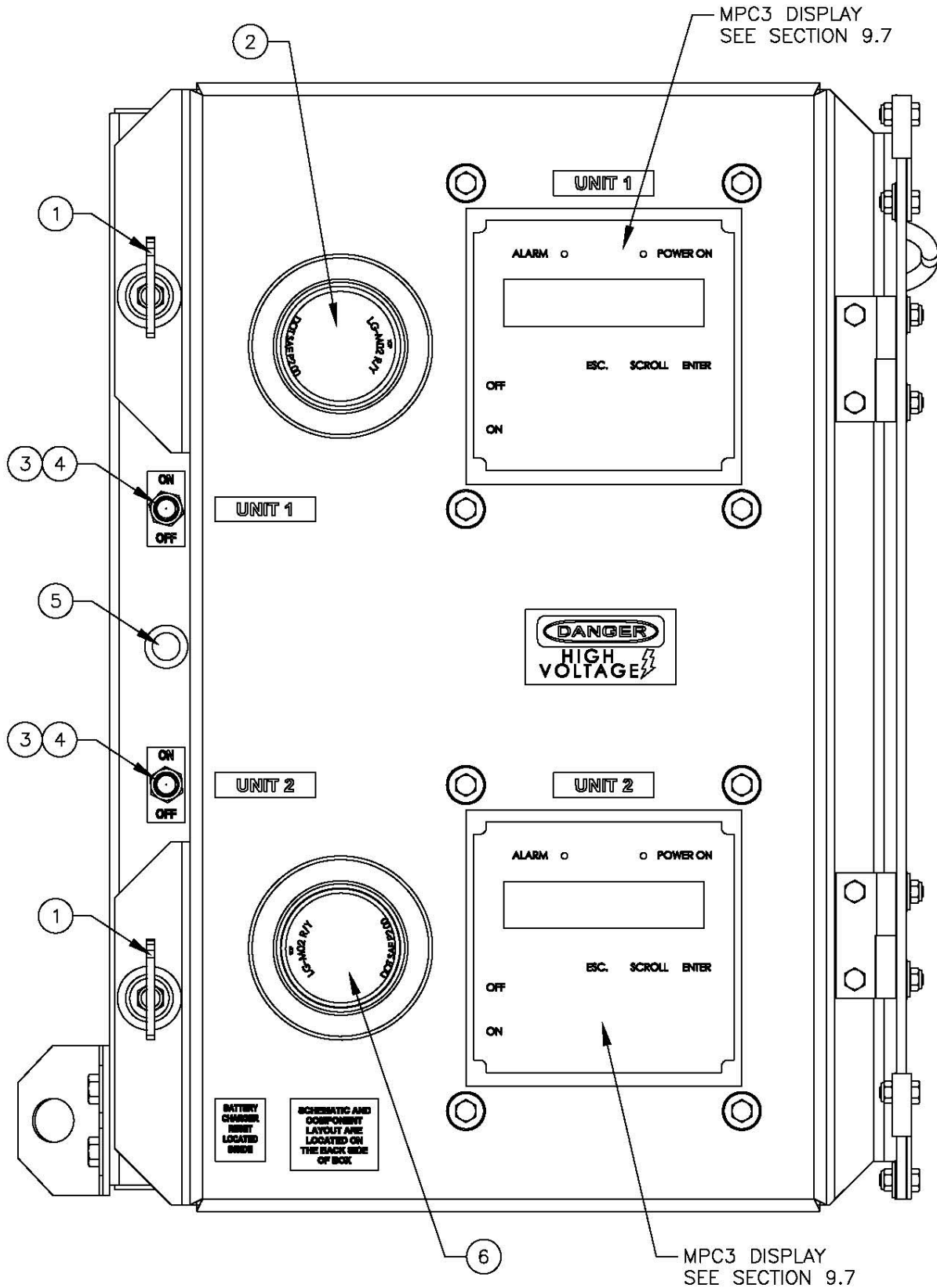

SECTION 9.6A

**CHANGEOVER BOX
(Outside)**

SECTION 9.6A CHANGEOVER BOX (Outside)

ITEM	PART NO.	DESCRIPTION	QTY.
1	K21-16313-00	FASTENER BABY ANTI-LUCE	2
2	360-15285-04	LAMP ALARM RED WITH CABLE UNIT 1	1
3	K24-22144-00	SWITCH TOGGLE 3PST ON-OFF 15A	2
4	K24-17239-00	BOOT TOGGLE SWITCH FULL IP 66/68	2
5	K28-10936-05	PLUG SEAL POLY FLUSH .50 HOLE	1
6	360-15285-05	LAMP ALARM RED WITH CABLE UNIT 2	1
7	360-13349-09	HORN PULSATING (not shown, mounted to back of Changeover Box)	1

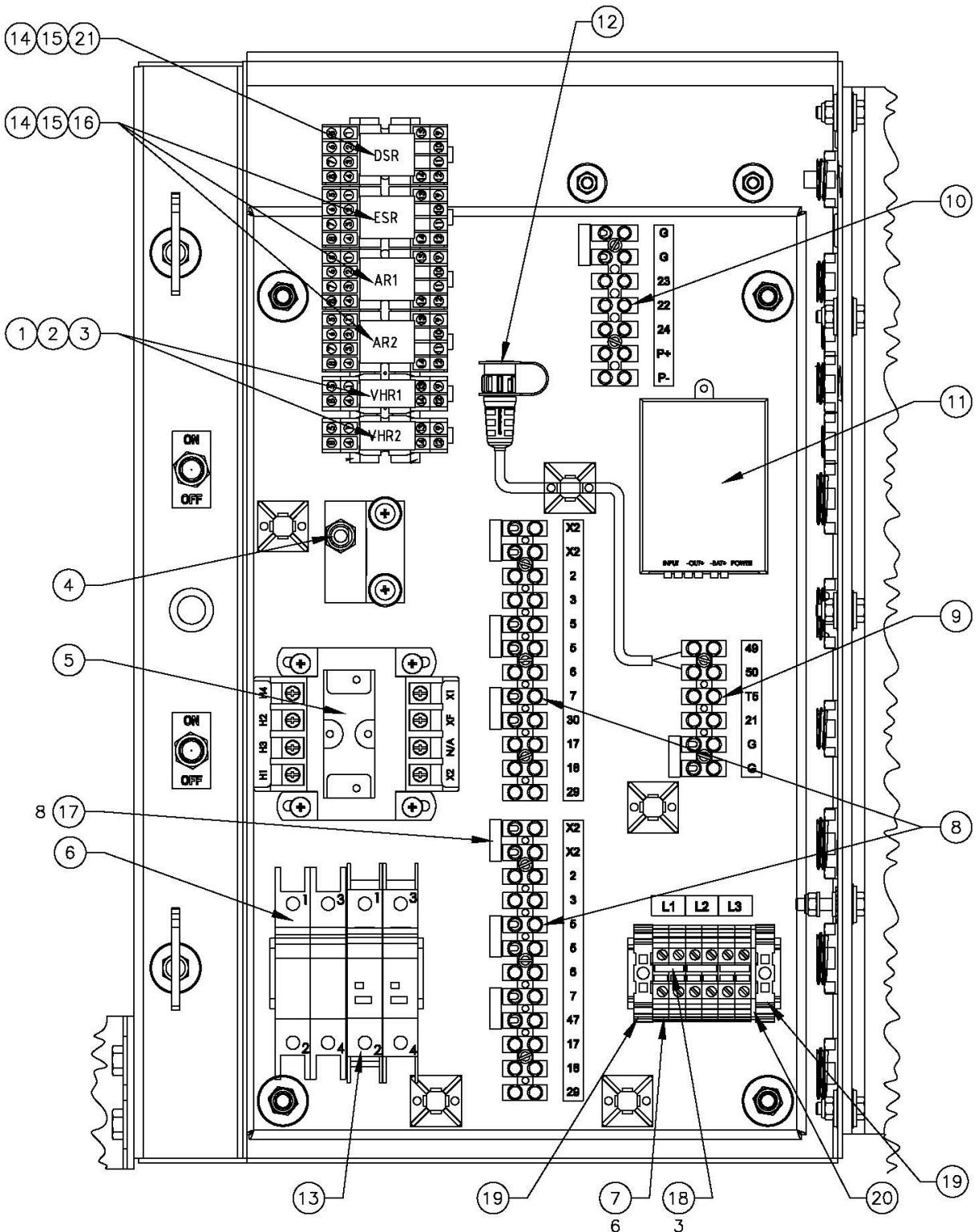

SECTION 9.6B

**CHANGEOVER BOX
(Inside)**

SECTION 9.6B CHANGEOVER BOX (Inside)

ITEM	PART NO.	DESCRIPTION	QTY.
1	K25-26265-02	SOCKET RELAY DPDT	2
2	K24-22264-03	RELAY 24 VAC MINI DPDT 3A	2
3	K25-26266-02	SPRING RELAY HOLD DOWN 2 POLE	2
4	K24-22330-00	CIRCUIT BREAKER 4A 1 POLE	1
5	K25-26972-00	TRANSFORMER 100VA PRI 240 X – 480 VAC SEC 24 VAC 50/60HZ	1
6	K24-58157-14	CIRCUIT BREAKER 10A 2 POLE	1
7	K25-26739-15	TERMINAL DIN RAIL MOUNT GRAY	6
8	K25-26488-12	BLOCK TERMINAL STRIP 12 45A	2
9	K25-26488-06	BLOCK TERMINAL STRIP 6P 45A	1
10	K25-26488-07	BLOCK TERMINAL STRIP 7P 45A	1
11	360-15580-01	BATTERY CHARGER MODIFIED 24VAC-12VDC 3A	1
12	360-17984-11	CABLE DATA DOWNLOAD MPC3-V2	1
13	K24-22441-02	CIRCUIT BREAKER 5 AMP 2 POLE	1
14	K24-22264-04	RELAY 12 VDC COIL MINI 4PDT 6A	3
15	K25-26265-00	SOCKET RELAY 4PDT 1/8 DIN MTG	4
16	K25-26266-00	SPRING RELAY HOLD-DOWN 4 POLE	4
17	K25-26550-02	JUMPER TERMINAL STRIP 8-18 GA 2 POLE 0.47 CENTERS	8
18	K25-26963-02	JUMPER TERMINAL UT6 2 POLE	3
19	K25-26933-00	END CLAMP NS DIN RAIL TERMINAL STRIP	2
20	K25-26962-00	COVER END TERMINAL UT 2.5-10 GRAY	1
21	K24-22264-00	RELAY 24 VDC COIL MINI 4PDT 5A	1

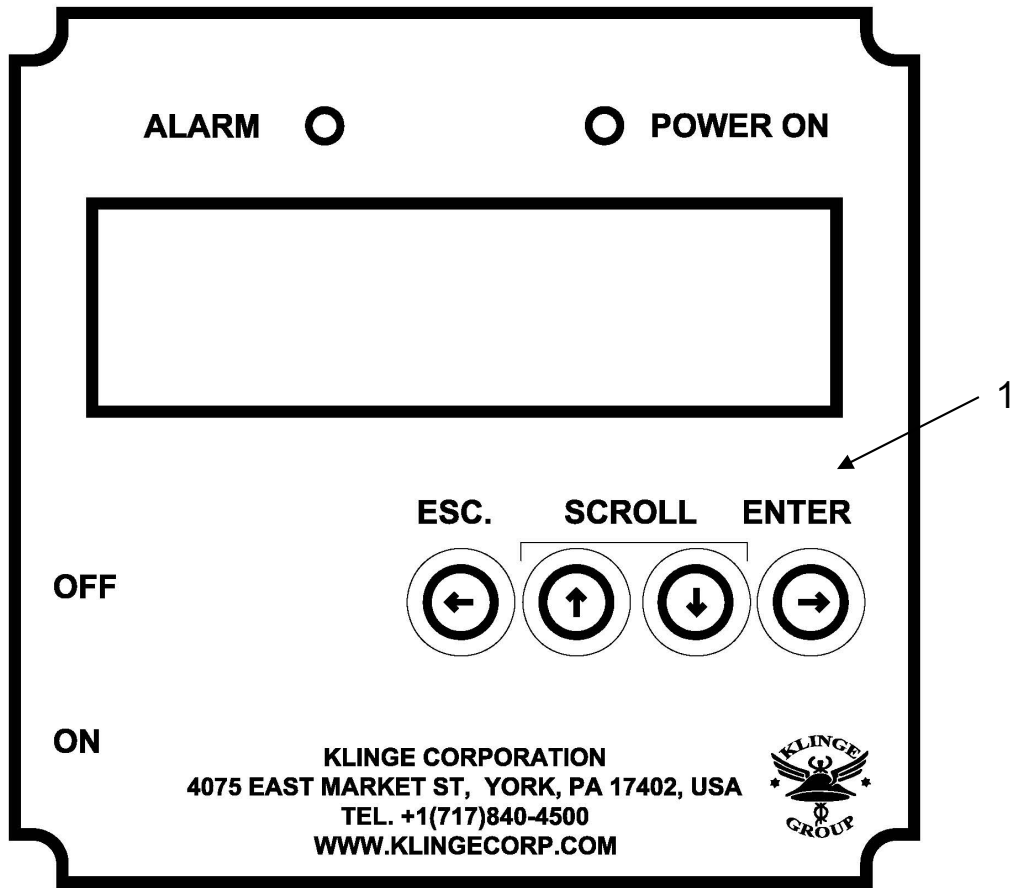

(Front)

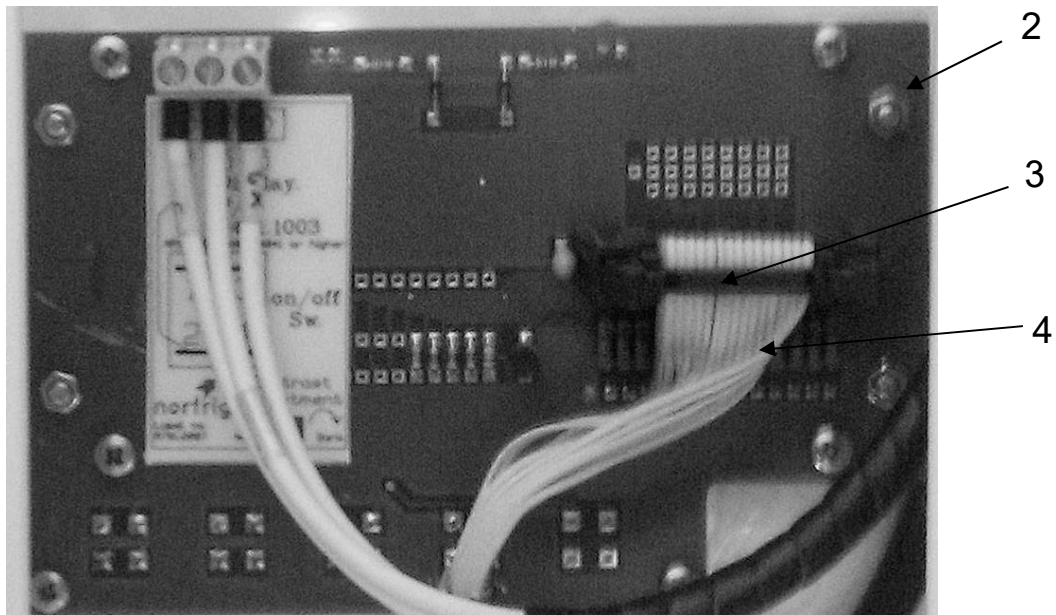

(Back)

SECTION 9.7 MPC3 DISPLAY

SECTION 9.7 MPC3 DISPLAY

ITEM	PART NO.	DESCRIPTION	QTY.
1	K35-06460-00	LABEL FRONT DISPLAY MPC3	1
2	K31-00929-10	DISPLAY TOUCH PAD CIRCUIT BOARD MPC-3	1
3	K25-26742-00	MULTI PLUG 16 POLE (DISPLAY CABLE)	2
4	K25-26775-00	CORD ELEC RIBBON FLAT TO ROUND 16 COND ORDER IN (MM)	9754mm

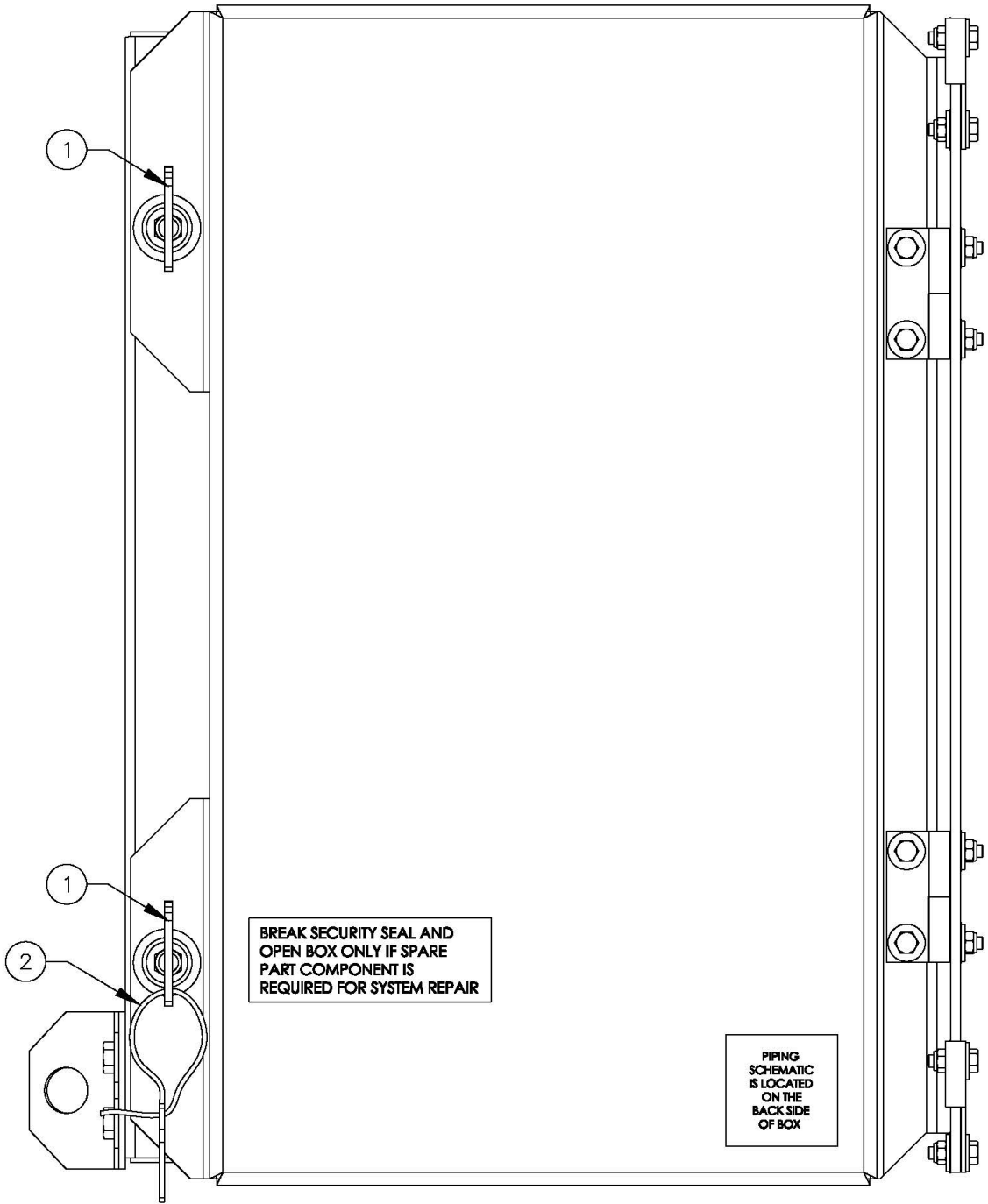

BREAK SECURITY SEAL AND
OPEN BOX ONLY IF SPARE
PART COMPONENT IS
REQUIRED FOR SYSTEM REPAIR

PIPING
SCHEMATIC
IS LOCATED
ON THE
BACK SIDE
OF BOX

SECTION 9.8A

**KIT SPARE PARTS (OPTIONAL)
(Outside)**

SECTION 9.8A KIT SPARE PARTS (OPTIONAL) (Outside)

ITEM	PART NO.	DESCRIPTION	QTY.
1	K21-16313-00	FASTENER BABY ANTI-LUCE	2
2	K21-16643-00	SEAL SECURITY	1

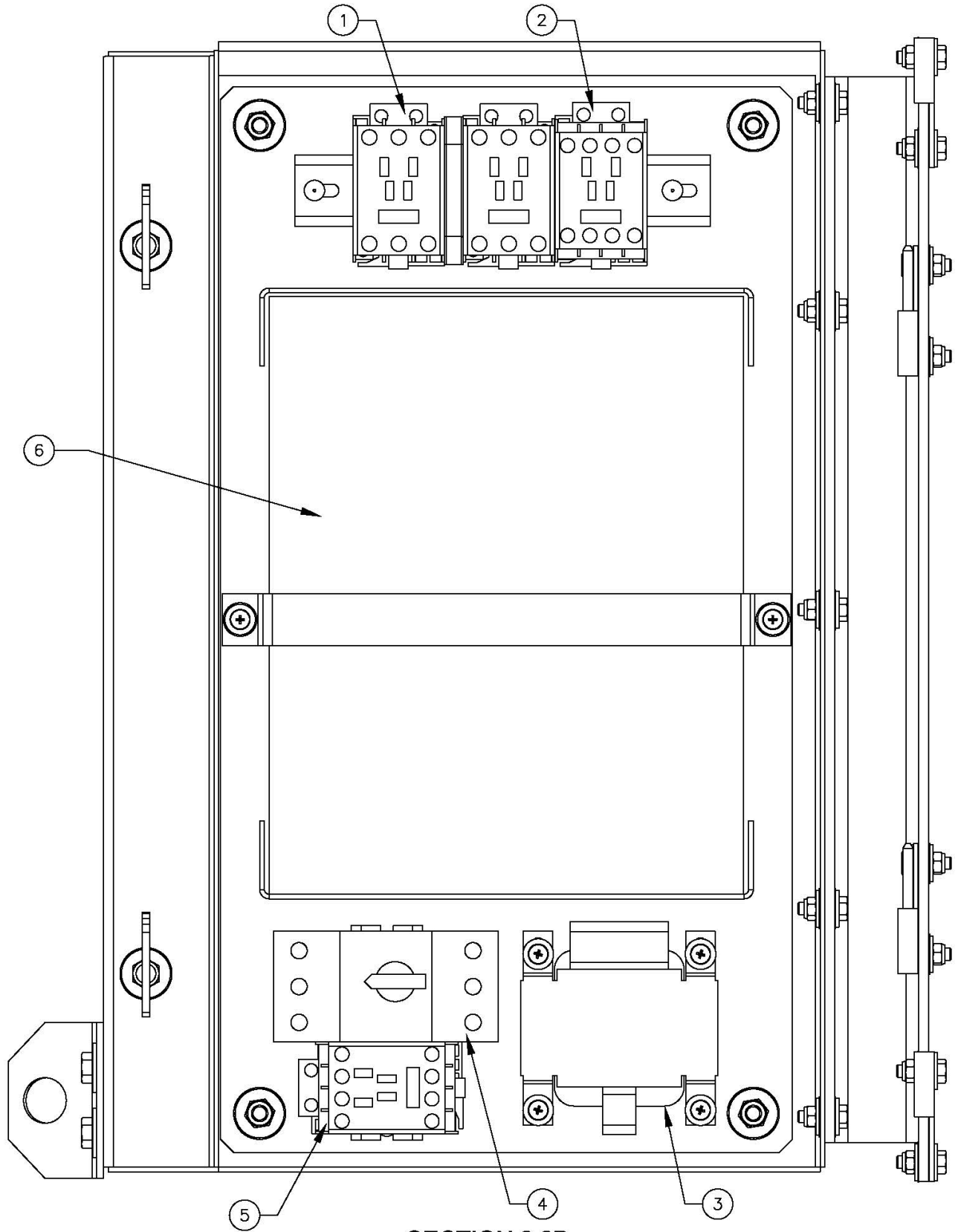

SECTION 9.8B

**KIT SPARE PARTS (OPTIONAL)
(Inside)**

SECTION 9.8B KIT SPARE PARTS (OPTIONAL) (Inside)

ITEM	PART NO.	DESCRIPTION	QTY.
1	K24-22315-30	CONTACTOR REVERSING 30A 6P 24/29 VAC 50/60HZ	1
2	K24-58160-05	CONTACTOR CI25 29V/60HZ	1
3	K25-26741-00	TRANSFORMER 480/28-4.6A/24-1A/20-1A 166VA	1
4	K24-22439-00	CIRCUIT BREAKER IEC 3P 23-32A	1
5	K24-58160-03	CONTACTOR CI12 29V/60HZ	1
6	360-16923-03	BOX SPARE PARTS MISC – SEE SECTION 9.8C	1

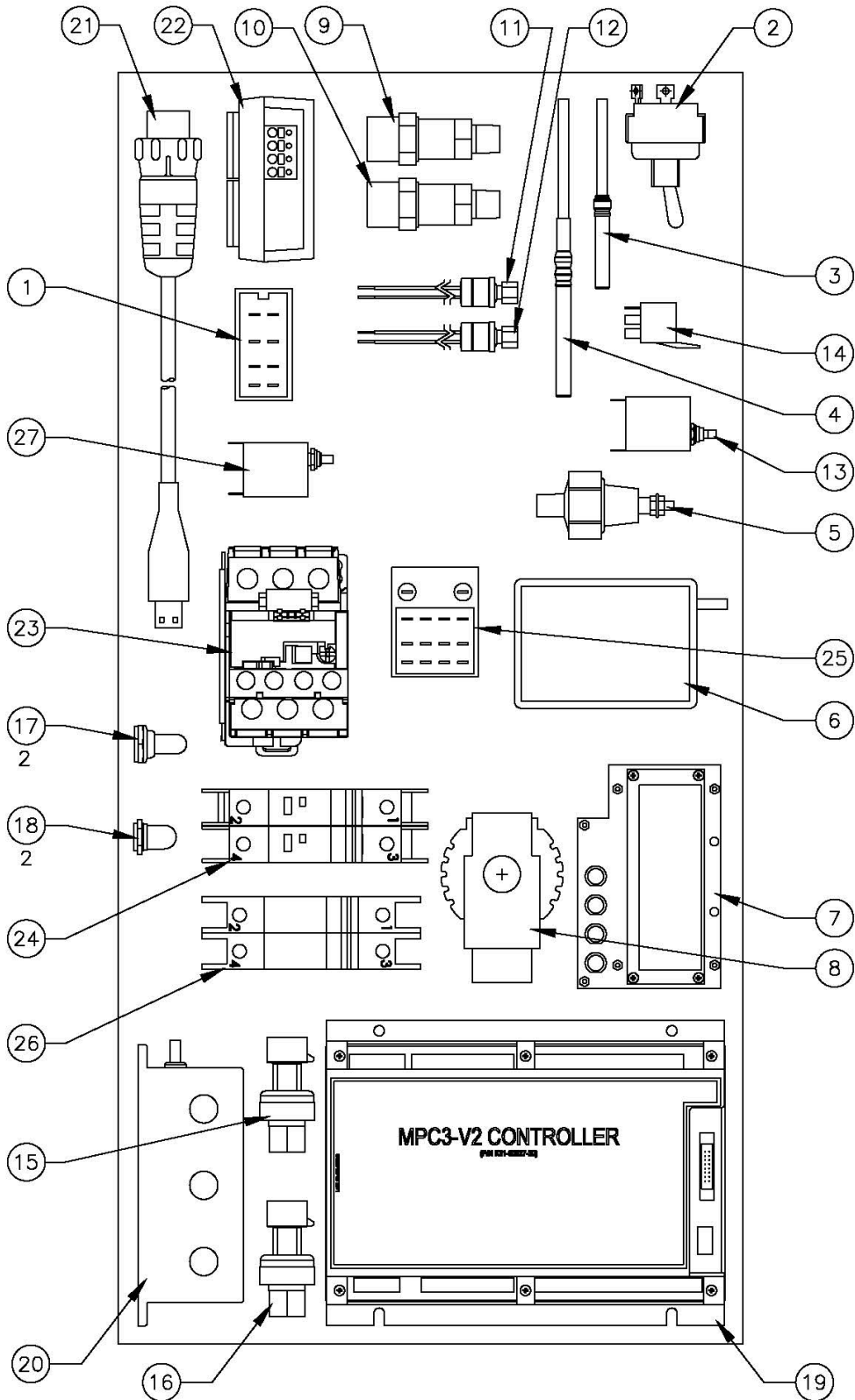

SECTION 9.8C

**BOX SPARE PARTS MISC (OPTIONAL)
(360-16923-03)**

SECTION 9.8C BOX SPARE PARTS MISC (OPTIONAL)

ITEM	PART NO.	DESCRIPTION	QTY.
1	K24-22264-03	RELAY 24 VAC MINI DPDT 3 AMPS GOLD PLATED SILVER CONTACTS	1
2	K24-22144-00	SWITCH TOGGLE 3PST ON-OFF 6-#6 SCR	1
3	K25-26808-00	PROBE 6MM OD PT 1000W/SILICONE CABLE	1
4	K25-26811-00	PROBE 6MM OD PTE MED NTC 2KOHM	1
5	XB-998208	SWITCH LOW OIL PRESSURE NC	1
6	360-17793-00	BATTERY PACK 6V 2000MAH MPC3 RECHARGEABLE	1
7	K31-00929-10	DISPLAY TOUCH PAD CIRCUIT BOARD MPC3 LABELED	1
8	360-17300-04	COIL SOLENOID NC	1
9	K22-07028-00	VALVE RELIEF (300 PSIG)	1
10	K22-07028-01	VALVE RELIEF (425 PSIG)	1
11	360-18463-00	CONTROL HP NC OPEN 350 CLOSE 250 18LG LEADS 18 GA	1
12	360-16405-20	CONTROL HP NC OPEN 400 CLOSE 300 PSIG PRESSURE SWITCH	1
13	K24-20565-00	CIRCUIT BREAKER 8A 1P	1
14	K24-22121-00	RELAY 12 VDC SPDT 30/40A	1
15	K25-26809-00	TRANSDUCER 0-200 PSI W/PACKARD CONNECTOR 2CPS-49	1
16	K25-26810-00	TRANSDUCER 0-500 PSI W/PACKARD CONNECTOR 2CPS-47	1
17	K24-17239-00	BOOT TOGGLE SWITCH FULL IP 66/68	2
18	K24-18164-00	BOOT CIRCUIT BREAKER 3/8-27 THD CLEAR	2
19	K31-00927-20	CONTROLLER MPC3-V2 LABELED	1
20	K25-26743-20	CURRENT SENSING TRANSFORMER 20A 3PH	1
21	360-17984-02	CABLE DATA DOWNLOAD	1
22	360-15580-01	BATTERY CHARGER MODIFIED 24VAC-12VDC 3 AMP	1
23	K24-22268-00	RELAY OVERLOAD 3P 1.8-2.8 BASE	1
24	K24-22441-02	CIRCUIT BREAKER 5 AMP 2 POLE -25C +60C	1
25	K24-22264-04	RELAY 12 VDC COIL MINI 4PDT 5A 1/8 TERM SILVER	1
26	K24-58157-14	CIRCUIT BREAKER 10 AMP 2 POLE	1
27	K24-22330-00	CIRCUIT BREAKER 4 AMP 1 POLE 1/4PO PANEL MOUNTING	1