

# KLINGE

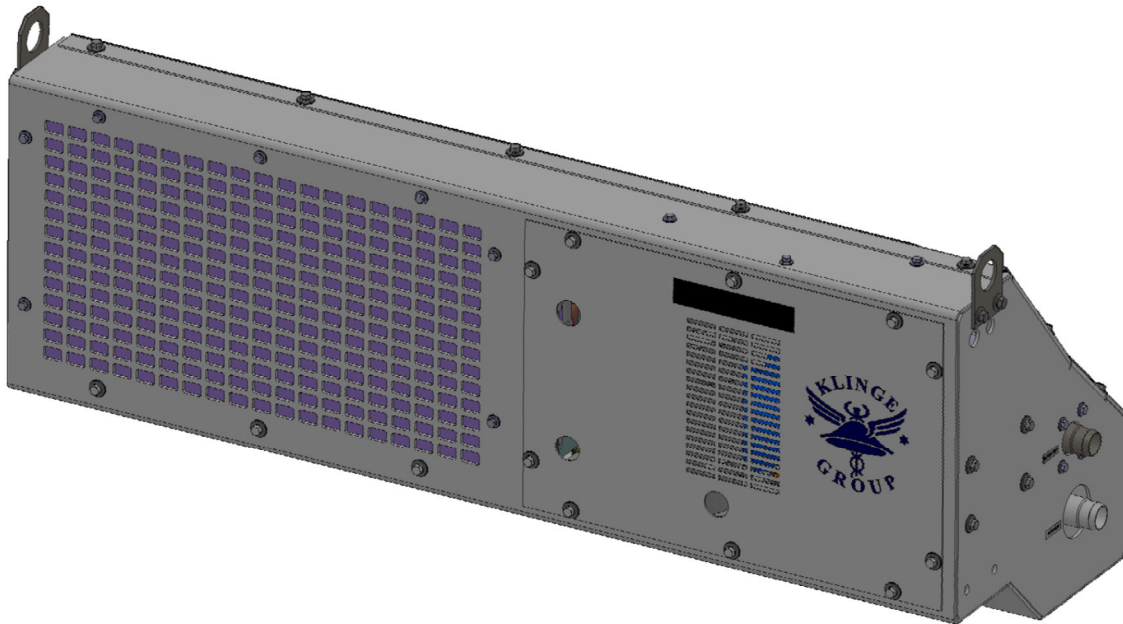

## MODEL TCR-109-41/42

### OPERATION, SERVICE AND PARTS MANUAL ROAD TANKER AND ISO TANK CONTAINER REFRIGERATION UNIT



Address: 4075 East Market Street York, PA 17402-5100 USA

Telephone: 717-840-4500    Telefax: 717-840-4501

[www.klingecorp.com](http://www.klingecorp.com)

MANUFACTURED BY KLINGE CORPORATION



## **Service Request**

Requests for Service should be directed to the Klinge Service Team. The below link should be used to place all requests for service and will afford the quickest response time.

<https://klingecorp.com/request-service/>

This form will help us determine model and age of the equipment, location, basic details about the issue, who to contact and how to best handle the issues with the equipment. A service ticket number will be provided in a response email once the form is received and processed. If the equipment is out of warranty, charges may apply for extensive technical support. Additionally, our Service Department can be reached via email at [technical@klingecorp.com](mailto:technical@klingecorp.com).

## **Spare Parts Request**

Requests for Spare Parts should be directed to our Parts Department via email at [spares@klingecorp.com](mailto:spares@klingecorp.com). Please have available at the time of the request the Serial Number of the equipment to ensure that the proper part is provided.

## **Use of this Manual**

The use of this manual is intended for the safe operation of the equipment described. It is therefore reasoned that persons who have the occasion to use this manual have a knowledge of mechanical and electrical systems and components addressed by its' contents. However, efforts have been made to enable persons less familiar with these systems to use this manual.

The equipment may be installed in a number of configurations. Each may have optional items and differing external details provided by third parties. The specific electrical circuit and pipe diagram are posted on the unit as decals.

Most external and internal pipework parts are standard commercially available pipe fittings and not covered here. For external pipe fitting, replace like for like, taking care to replace stainless steel with stainless steel.

Suggestions as to improvement in content and format are welcome and should be addressed to [engineering@klingecorp.com](mailto:engineering@klingecorp.com). Corrections and improvements will be included on dated revisions – the latest of which will be available upon request.

## Common Optional Items Are:

- Electrical heat – any size up to 12kW can be provided. There are several mounting locations on the TCR unit for the heater but it may also be mounted on the container. The preferred orientation of a heater is to have it piped in series with the outlet of the pump with the element horizontal.
- Various heat transfer fluids
- Onboard independent data logger.
- Remote telemetering signals to an external data logger and/or
  - Satellite communication aerial.

As stated elsewhere, various heat transfer liquids can be used specific to the application, the common heat transfer liquid being diluted ethylene glycol for most chemicals and diluted propylene glycol for food grade tanks. For high temperature cargoes synthetic oils may be used. For very low temperature and hazardous cargoes that react with water or water-based coolants “Dowtherm Q” has been used.

- Special note on using Dowtherm Q

Dowtherm Q is a by-product of Diphenylethane Ethylenated benzene, a proprietary composition and brand of low temperature heat transfer liquid made by Dow Chemicals. It is an excellent heat transfer liquid with a freezing point of  $-40^{\circ}\text{C}$ . It is not a “hazardous chemical” as defined by the USA OSHA Hazardous Communication Standard, 29 CFR 1910.1200, but must be handled with care.

Maintenance mechanics should be made aware of the hazards of handling the liquid and the local legislation relating to recycling, recovery and disposal. This is available on the appropriate safety data sheet.

Klinge can fax or email you the latest revision of the US/Canadian Material Safety Data Sheet or your local Dow Chemical sales and technical support office can send you a copy of the same data particular to your location, language, custom and legislation.

It is a paint stripper, keep it off the tank’s paintwork. It will dissolve bitumen, black top road surfaces, keep it off the tarmac. Over time coolant reacts with and dissolves natural and synthetic rubbers and some plastics as used in the flexible hose, the pump seal and the bladder of the pneumatic expansion tank.

This requires a planned maintenance program to periodically inspect and replace these parts. Klinge Corporation Engineering Department can give advice on a particular installation configuration and service interval. The owner and operator are encouraged to contact [engineering@klingecorp.com](mailto:engineering@klingecorp.com) once the tank using Dowtherm Q enters service.

# Contents

GENERAL SAFETY .....	7
<b>SECTION ONE - GENERAL DESCRIPTION, INSTALLATION, OPERATION .....</b>	<b>10</b>
1.0 Nomenclature.....	10
1.1 Refrigeration System Assembly .....	10
1.2 Scroll Compressor Assembly.....	10
1.3 Circulating Pump Assembly.....	11
1.4 Chiller Assembly .....	11
1.5 Installation Procedures .....	11
1.6 Connecting TCR-109 to the Tank Cooling System .....	12
1.7 The Expansion Tank System .....	13
1.8 Installation Checkout Procedure .....	14
1.9 TCR-109 Standard Operating Procedures .....	14
<b>SECTION TWO - DETAILED FUNCTIONAL DESCRIPTION.....</b>	<b>20</b>
2.1 Refrigeration System Operation .....	20
2.2 (Heat Transfer Fluid) Circulating System Operation.....	21
2.3 Pressure Controls and Safety Devices .....	21
<b>SECTION THREE - GENERAL MAINTENANCE REQUIREMENTS.....</b>	<b>23</b>
3.1 Pre-Trip Maintenance.....	23
3.2 Safety Precautions .....	23
3.3 Checking and Adding Refrigerant Charge .....	24
3.4 Checking and Adding Refrigerant Oil .....	25
3.5 Leak Detection .....	25
3.6 Evacuating the Refrigeration System .....	26
3.7 Opening the System or Unbrazing Components .....	26
3.8 Heat Transfer Fluid Circulating System .....	26
3.9 Hi-Pot Testing.....	27
3.10 General Description Klinge Corporation Thermostat.....	28
<b>SECTION FOUR - TROUBLESHOOTING .....</b>	<b>31</b>
4.1 General Information .....	31
4.2 Electronic Thermostat .....	31
4.3 Refrigeration System.....	31
4.4 Circulating System .....	31
4.5 Electrical System .....	31
<b>SECTION FIVE - OPTIONAL PRESSURE CIRCULATING SYSTEM.....</b>	<b>40</b>

5.1 Pressurized Circulating Heat Transfer Fluid System .....	40
5.2 Air Trap and Vent.....	40
5.3 Filling the Heat Transfer Fluid System .....	40
5.4 The Expansion Tank Charge.....	42
5.5 The Pump .....	42
5.6 Air Blockage.....	42
5.7 Charging Steps Checklist for a Closed Pressurized System .....	43
5.8 Filling the Glycol Pressure System and Venting the Air .....	45
5.9 PTI Form.....	45
<b>SECTION SIX - INSPECTION AND REPAIR.....</b>	<b>46</b>
6.1 Compressor .....	46
6.2 Condenser Blower Motor and Heat Transfer Fluid Pump Motor.....	48
6.3 Filter Drier Replacement.....	48
6.4 High Pressure Switch .....	48
6.5 Thermal Expansion Valve .....	49
6.6 Electrical Schematic .....	51
6.7 Thermostat Operation .....	52
<b>SECTION SEVEN - SERVICE PARTS .....</b>	<b>54</b>
<b>ADDENDUM – DUAL SYSTEMS.....</b>	<b>74</b>
A.1 General Description.....	74
A-2 Dual System Configuration .....	74
A-3 Dual System Operation.....	74
A.4 Dual System Alarm Codes .....	75
A.5 Dual System Electrical Schematics .....	76
A.6 Dual System Installation Kit Drawing.....	78
A.7 Dual System Control Box #1.....	79
A.8 Dual System Control Box #2.....	80

## GENERAL SAFETY



**Refer to Operation and Service Manual before operating and servicing equipment.**



**Use proper lockout/tagout procedures before servicing equipment.**



**Wear ear protection when working around the equipment for extended periods of time**



**Safety glasses should be worn at all times when operating or servicing the refrigeration unit.**



**Do not use this Equipment for any purpose not described in this Manual.**



**Do not operate this equipment without all guards and covers in place.**



**Do not operate this equipment from any power source that does not match the voltage rating stamped on the equipment. Refer to the Manufacturer's Identification Label for operational requirements.**



**Beware of high voltage (400-480 volt) in various parts of the unit, especially when CB1 is in the ON position. It is recommended that a thorough study of the wiring diagram be made to determine where high voltage may be encountered when electric power is fed to the unit.**



**Note: The electrical system will automatically restart the unit in case of power failures.**



**Refrigerant is heavier than air. Therefore, it settles in the lowest places and will expel air (oxygen) from a small confined space, resulting in dizziness or suffocation to an occupant.**



**Arc flash potential when equipment is operating.**



**Fans present possible hand injury when equipment is operating.**

**When installing, operating or servicing the equipment, follow all local regulatory standards.**

**All service and maintenance procedures should be performed in accordance with Section 608 of the Clean Air Act (CAA), prohibiting the venting of refrigerants into the atmosphere and providing for the use of refrigerant recycling and recovering equipment to be used whenever a system is opened.**



**Always wear approved goggles or eye shields when working with refrigerant to prevent eye injury if refrigerant is accidentally discharged into the face of the service engineer.**

- When any work is to be done on the components of the refrigeration system, be sure that the unit cannot be started automatically or accidentally. If valves are closed and/or circuits interrupted during service procedures, the control switches should be suitably tagged with such notations.
- Do not exert excessive pressure when tightening flare nuts, as it may result in a rupture of the flare or stripped threads.
- Never, under any circumstances, apply heat to a refrigerant cylinder by using a naked flame. Should it be considered necessary to apply heat to a cylinder to create a refrigerant flow when recharging a system, place the cylinder in a container of hot or warm water to a point about 3/4 of the height of the cylinder.
  - Even this method requires that a pressure gauge is in use in the charging line to indicate the pressure in the cylinder at all times.
  - Never close the shut-off valve in the cylinder while the cylinder is being heated.
  - The use of a manifold gauge set will permit compliance with CAA regulations by having a gauge in the line and a shut-off valve on the



manifold to stop the flow of refrigerant into the system and allow the gauge to read cylinder pressure.

- Always replace refrigerant cylinder valve and connection caps after using the cylinder, and do not permit a cylinder to be dropped or hit severely by another object.

### EQUIPMENT CLEANING

If it should become necessary to clean the exterior of the electrical panel of this equipment, do not use liquid cleaners, aerosols, abrasive pads, scouring powders or solvents, such as benzine or alcohol. Use a soft cloth lightly moistened with a mild detergent solution.

### DISMANTLING AND DISPOSAL

360. Hydraulics/Lubricants – Must be recycled as required by local environmental law – do not dispose of by pouring down the drain.



2. Electronics – Must be recycled as required by local environmental law – do not dispose of by adding to the Municipal waste stream.



3. Metal/Other Parts of the System – Must be recycled as required by local environmental law.



4. Refrigerant – Must be reclaimed and recycled as required by local environmental law. Do not release refrigerant into atmosphere.



# **SECTION ONE - GENERAL DESCRIPTION, INSTALLATION, OPERATION**

## **1.0 Nomenclature**

The TCR-109 is specifically designed to fit the bottom side rail of beam and frame tanks.

The last two digits record the “as built” details.

As ISO convention dictates, we label the rear of the tank container as the end with the discharge valves. Our norm is to mount the unit on the right-hand side when viewed from the front. It can be mounted on either side, however, care must be taken to match the unit with the cooling/heating coil circuits and connections.

For particularly hazardous cargoes two units can be mounted – one either side – giving 100% machine redundancy as security for the cargo integrity. This manual assumes there is a single unit that is fitted on the right-hand side.

The control box is also normally mounted on the right-hand side of the rear of the container, that is, on the left viewed from the rear. NOTE: Because it is beveled to fit the contour of the tank, the control box is “handed”, that is, in the normal condition it is a right-hand unit (left hand if viewed from the rear).

## **1.1 Refrigeration System Assembly**

The TCR-109 is a refrigeration system, with an optional heating system, available in combination. It is designed for uses in combination with heat transfer fluids where different types of cargo require a different temperature range.

Basic equipment associated with the TCR-109 includes: a scroll compressor using R-404A or R-452A, a condensing section, a chiller section, a circulating pump section, and an optional heater available (a detailed description of the system is located in Section 2).

An adjustable electronic thermostat controls the temperature of the cargo and the thermostat is also linked in the electrical system to control operation of the TCR-109.

The unit is compact and lightweight fitting neatly alongside the tank container. Either on the bottom side rail of a frame tank or by using brackets it can be attached to the belly of a beam tank. The unit is designed so that mounting is simple and can be accomplished quickly. Hook-up to the tank’s coil system must be designed in conjunction with the ISO tank manufacturer’s connections.

## **1.2 Scroll Compressor Assembly**

The latest in refrigeration technology is applied to the TCR-109 by using components that require a low level of maintenance intervals, such as, the scroll compressor with its simplicity in design and operation. The scroll design can typically achieve higher compression ratios, which

allows the compressor to produce lower temperatures for the cargo without adding additional weight.

### **1.3 Circulating Pump Assembly**

The circulating pump assembly is a close-coupled centrifugal pump and motor. The circulating pump assembly is low maintenance with sealed bearings supporting the motor and the fluid being pumped through it provides lubrication for the pump.

### **1.4 Chiller Assembly**

The chiller assembly is a 3 ton rated unit. It is a shell and plate constructed unit designed to be maintenance free. The chiller is the interface between the TCR-109 refrigeration system and the tank coil system.

### **1.5 Installation Procedures**

The installation of the TCR-109 is designed to be accomplished with relative ease. On frame tank containers the installation is directly to the lower frames on either side. On beam tank containers the installation is accomplished by using brackets, which are provided, allowing the unit to be attached to tank stiffeners. In either case, a drawing will accompany each new installation showing the attachment assembly for the TCR-109.

**CAUTION:** Be sure to follow all applicable safety precautions when performing maintenance in the vicinity of heavy machinery. Ensure there is adequate ventilation when handling halogens and hydrocarbons. Ensure that proper personal protective equipment is in place and in use before beginning this installation.

#### **1.5.1.1 Installation Procedures, Frame Tank Container**

The following is a general procedure. Use the assembly drawing as a guide for specific locations and fittings and see the detailed drawing package for the individual installation.

For general design purposes, there is a general installation set of drawings that can be emailed upon request.

The dry weight is approximately 181 kg, 400 lbs.

When suspended by the lifting points, the majority of the weight is towards the face of the unit and on a frame tank is reacted by the bottom side rail.

An alternative for some beam tanks is to mount the unit to an attachment to the stiffening rings of the tank. It would be usual, in this case, to consult the classification society for a ruling on the interpretation of ASME VIII for such an attachment.

#### **1.5.1.2 Preparation of Frame Mounting Surface**

Prior to final painting, the holes and brackets to hold the unit and threaded bolt to attach the earth strap, should all be made and then fully painted and allowed to cure.

#### **1.5.1.3 Installation of TCR-109 onto Frame Member**

The unit has two holes fitted with M10 X 1.5 nut inserts, on each end, adjacent to the bottom rail cutout. These are to be used in conjunction with a simple angle to attach the unit to the beam.

The rear of the unit can have additional threaded holes. The rear of the unit requires some support to resist the turning moment, as the unit will want to rotate about the bottom rail. This can be arranged with a beam or bracket attached to a transverse frame member or the chassis interface members of the tank.

Because the tank frame rail is steel and our unit body is constructed of aluminum, we ask for an electrolytic barrier such as a 1-mm thick gasket of synthetic rubber or plastic to be placed between beam and unit.

Each end of the unit will have bolt holes into which simple angle brackets will be placed. (These will not normally be supplied, but made by the tank builder.) The tank manufacturer will be asked to provide a simple angle plate with drilled holes to weld to the beam to provide a bolting plate. Again, electrolytic insulation will be required between steel and aluminum.

Usually, the tank builder will be asked to provide either bolt-on angles forming “wings” to the back of the unit, or a longitudinal beam along the back of the refrigeration unit built into the tank. This angle could be an unequal angle or channel extending over 2m to suitable strong points. Again, it will require electrolytic insulation and some form of packing and transitional piece, which can only be detailed when the frame details are known.

### 1.5.2 Installation Procedures, Beam Tank Container

An alternative option would be to attach the rear of the unit to the tank at an existing stiffening ring or a short section of additional stiffening ring.

Our interpretation of ASME VIII allows for this but the tank builder or owner would have to seek class approval for the applied load and possibly for the effect of differential thermal expansion and vibration.

Care must be taken in detailing the interface components not only to take care of the resulting forces but also to take into consideration:

1. Differential thermal expansion between the tank and the unit.
2. Thermal insulation and thermal bridging between components attached to the tank through the insulation.
3. The electrolytic corrosion of dissimilar metals.
4. The requirement to provide a common earth throughout the whole of the tank and its components.

## 1.6 **Connecting TCR-109 to the Tank Cooling System**

The unit is shipped complete with the first piece of the inlet and outlet pipework. This includes a simple sight glass made from a short length of translucent wire reinforced plastic pipe. These pipes must be connected to the tank’s cooling system. The normal arrangement would be to have a suitable length of pipe welded directly to the pipes provided and either hard or flexible

pipework to the tank's cooling system. It is recommended that hand valves be put in the discharge and return lines, for ease of service.

With a newly constructed tank it would be preferable to terminate the heating pipes adjacent to the machine, and whenever practical, to have the pipes under the insulation of the tank.

## **1.7 The Expansion Tank System**

### **1.7.1 The Atmospheric Pressure Expansion Tank (for pressurized units see Section 5)**

This unit requires a separate, externally mounted, atmospheric pressure expansion tank for the cooling medium. This is equivalent to the expansion tank found next to the radiator in most modern cars.

Klinge Corporation can supply a bolt-on tank or the builder can fabricate it as part of the tank frame.

It is basically very simple, and we suggest the builder fabricate and install it rather than have to integrate a U.S. made tank. Some tank builders use a plastic proprietary truck expansion tank.

The tank should be approximately 2-gallon capacity, built to fit high up on the frame with access on the walkway for filling purposes. It should have a "no pressure" radiator cap type filling port and a single large bore "in and out" port connected to the cooling system. It is not a pressure vessel.

The cap, if of the pressure type, should have a small vent hole drilled in it or in a high point in the tank.

The pipe from the expansion tank to the unit may be clear plastic but must be of large bore, for example 40mm (1.5") and would ideally be piped under the insulation for most of its routing.

The pipe may be wire reinforced plastic or similar as long as it can withstand the extremes of the operating temperature.

### **1.7.2 Cleanliness of the Heat Transfer Fluid System**

New cooling systems are typically coated with oil, grease, or protective film during fabrication. Welding byproducts, flux and scale that would not normally cause a problem with a steam system can cause a problem with the heat transfer fluid heat exchanger – the chiller.

Dirt will migrate to the chiller (a plate type heat exchanger) and may block the small gaps between each plate. Because of this, thoroughly cleaning the new system is important.

A solution of 1 to 2% trisodium phosphate (TSP) (available at most hardware stores) can be used with water for flushing the cooling pipes.

The system volume can be calculated at this stage by metering in the cleaning material.

This cleaning should be completed prior to connecting the TCR-109 unit.

We suggest that a gauze or muslin cloth be used to filter and observe the output of the cleaning medium. Use the lack of returning dirt as a guide to cleanliness.

NOTE: As it is an inherently closed loop system, the unit purposely does not have the restriction of an in-line filter in the heat transfer fluid line and depends on the heating system being cleaned at the initial charge filling.

### 1.7.3 Venting

To initially charge the system and release entrapped air, the heating system coils will require vents.

The pump is not self-priming, however, with sufficient head of liquid from the initial filling, the pump may be run intermittently to assist in venting the system.

There is a Schrader valve vent fitted after the pump, before the chiller, the head of which can be seen coming through the insulation. On initial filling, air tends to be trapped in this area and should be vented.

Klinge Corporation can supply the vents, but we need to look to the installer to provide the pipes through the insulation. Without final details of the heating coils it is impractical to suggest how many vents are required. In practice, one per high point on the coils would suffice.

## **1.8 Installation Checkout Procedure**

In order to ensure that the TCR-109 will operate as designed and provide trouble free operation, it is important that this checkout procedure be completed.

### 1.8.1 Circulating system Charging Procedure

The circulating system is charged with heat transfer fluids. Refer to paragraph 3.8 for details of system charging.

### 1.8.2 Operational Testing

Operational testing should be accomplished on the initial installation per clause 1.9: see clause 3.1 regarding pre-trip maintenance.

## **1.9 TCR-109 Standard Operating Procedures**

### 1.9.1 Pre-Starting Check

It is important to perform a basic check prior to any operation of the TCR-109. It will assist the operator with assessment of system reliability. The items that should be checked are:

1. Visually inspect unit for physical damage. Observe for signs of leaks. Check condenser coils and clean if required.
2. Check hold-down bolts and ensure that they are not loose.

3. Open the electrical control box and inspect it to ensure that all connections are tight and electrical components are secured properly. Check that the door gaskets seal properly.

### 1.9.2 Starting the TCR-109

Connect the main power plug into a receptacle rated at 480V AC to supply power to the unit. Check to ensure that CB1, CB2, and CB3 are in the "ON" position. If the system is equipped with Option 5 and/or Option 10 (see Section 6.6 Electrical Schematic,), circuit breakers CB4 and CB5 respectively, must be in the "ON" position.

**NOTE:** The TCR-109 is equipped with an electronic thermostat when the unit is started a function test (paragraph 1.9.6) should be done to ensure the thermostat will function properly.

Start the unit by placing the "ON/OFF" switch in the "ON" position. Adjust the thermostat temperature to the desired set point and allow the unit to run for a few minutes. Observe oil level in the compressor and refrigerant level in the sight glass of the receiver and the filter assembly.

1. The compressor is not fitted with a pre-heater. On initial startup, particularly after a long period of storage, the compressor may make a loud vibration noise. This is normal for a few seconds, however, if it persists, stop the unit and check to ensure that the three-phase wiring is correct and that the compressor cycle of rotation is correct.
2. The compressor sight glass may have a surge of bubbles on initial startup. These bubbles should start to clear within the first few minutes of operation. The colder the ambient temperature is the longer this may take.
3. The receiver sight glass (lower) should be flooded, with the bead inside floating. The upper sight glass should be free of liquid with the bead resting. However, on initial startup the gas and liquid may migrate around in the system until a stable condition is reached. This could take up to 30 minutes but should become stable shortly after the bubbles clear from the compressor sight glass.

### 1.9.3 Temperature Selection

Once a temperature is selected, the control point is determined and the thermostat governs the cycles of the TCR-109. The temperature indicated is dependent on the installation of the probes. This may be in either the heat transfer fluid or in the well in the cargo compartment or in some cases on the outer skin of the tank. The temperature response of the system will be determined by the location of the sensor.

The system is adaptable to customer requirements. The location of the thermo-well is determined by the customer, but in general, for tanks designed to carry full loads, it is located 1/3<sup>rd</sup> up the height of the liquid and some distance from any heating or cooling coils.

For partitioned tanks able to carry less than full loads the thermostats should be mounted in a lower position to be covered by the minimum liquid likely to be carried.

The thermostat allows for two control probes, one in the cargo and one in the cooling \ heating medium to heat or cool the cargo. By definition, the heat transfer medium must be higher or lower than the cargo. The temperature of some cargo may be varied by raising or lowering the temperature of the heat transfer fluid. Locally sub-cooling or locally overheating the cargo at the point at which the heat transfer fluid first comes in contact with the tank may be a problem with

some liquids. This is particularly true when the carriage temperature is near the freezing point of the cargo. The heat transfer fluid limit temperature prevents this. See Section 1.9.5.

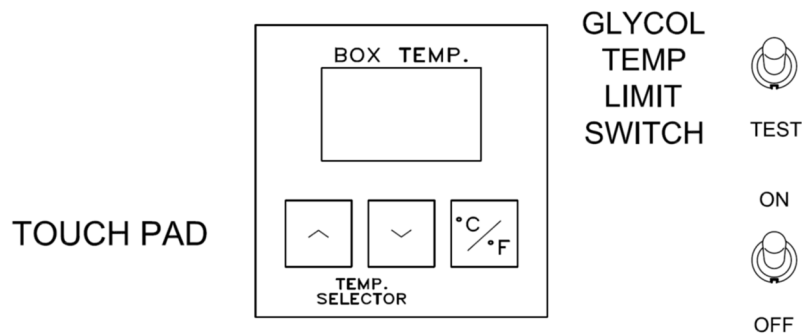

Creating a temperature set point:

1. Pressing the **UP** (^) or **DOWN** (v) key causes the display to show the current set point.
2. After the current set point is displayed, each pressing of one of these keys will increment or decrement the display by one whole degree.
3. Holding a key pressed will cause the display to change one degree each half second.
4. Simultaneously pressing both keys causes the current set point to be saved. This set point will be used until another set point is chosen, even if power is removed from the thermostat.
5. The display automatically returns to normal mode approximately 5 seconds after the last key pressed.

**NOTE:** The equipment can be protected from accidental or unauthorized changing of the set point by using a PIN Code. If a PIN Code is in use, contact the equipment owner for the code, then use the below step by step process for entering the PIN Code to allow you to change the Set Point.

1. When the unit is in operation the current Set Point will be displayed by pressing either the UP or DOWN button. This will display the current Set Point.
2. When you press either the UP or DOWN button again the word “Pin” will be displayed.
3. When the word “Pin” is displayed you then press the C/F Key one time.
4. The display will now show 0 as the first digit, at this time you will need to enter the first digit of the PIN Code.
5. Once the first digit has been entered press the C/F key to move to the second digit.
6. The display will now show 0 as the second digit, at this time you will need to enter the second digit of the PIN Code.
7. Once the second digit has been entered press the C/F key to move to the third digit.
8. The display will now show 0 as the third digit, at this time you will need to enter the third digit of the PIN Code.



9. Once the third digit has been entered press the C/F key to confirm the PIN CODE that you have entered.
10. If the PIN Code that has been entered is not correct the Temperature Display will read "Pin".
11. If the code that has been entered is correct the Temperature Display will show the Return Air Temperature. At this point the Set Point can be set through the normal process. It should be noted that the Set Point will remain unlocked for 3 minutes after the PIN Code has been entered. After 3 minutes the PIN Code will need to be entered again.

Changing temperature mode:

1. The thermostat can operate in either degrees Centigrade (C) or degrees Fahrenheit (F).
2. Pressing the C/F key causes the display to indicate the current mode. This is indicated by a C or F in the right character of the display. The right most decimal point in the display is also illuminated when in F mode.
3. Each pressing of the C/F key causes the mode to change.
4. After selecting degrees C or degrees F, pressing either the up or down key will cause the currently selected mode to be saved and the display will immediately return to normal mode.
5. The display automatically returns to normal mode approximately 5 seconds after the last key pressed.

1.9.4 Temperature Sensor Probe

The temperature sensing probe is a thermistor placed in a sealed (epoxy filled) metal tube, which is connected to a two conductor shielded cable. The temperature signal from the probe is relayed to the thermostat through this cable. An open or shorted probe will be indicated.

Accuracy of the probes is:

TEMPERATURE RANGE	TOLERANCE
-40°C to -20°C	+/-0.75°C
-20°C to -10°C	+/-0.4°C
-10°C to 70°C	+/-0.2°C

Checking of temperature should be done with an instrument with equal or better accuracy. The thermostat cannot be calibrated.

If the cargo probe has an open or shorted circuit, the glycol probe will take over as the controlling probe. When failure occurs the cooling light will start flashing.

If a probe or cable becomes defective, check the probe assembly and the thermostat connection first to confirm a shorted or open circuit. Then disconnect the probe to determine whether the probe or cable is defective.



**It is important that the sensor is properly mounted. Use an ohmmeter to check probes. A short circuit indicates 0 Ohms resistance. An open circuit indicates infinite Ohms resistance. Good readings should agree with the chart below:**

<b>PROBE RESISTANCE CHART</b>		
<b>Probe at Ambient Temperature</b>		<b>K-Ohms (Approx.)</b>
<b>°C</b>	<b>°F</b>	
+ 25	+77	10.0
+ 20	+68	12.4
+ 15	+59	15.7
+ 10	+50	19.9
+ 5	+41	25.3
0	+32	32.6
- 5	+23	42.6
- 10	+14	55.3
- 15	+5	72.9
- 20	- 4	97.0
- 25	-13	130.3

#### 1.9.5 Setting the Upper and Lower Limit for Heat Transfer Fluid

The function of this setting is to limit “local under cooling” or “local over heating” of the cargo. In order for the circulating heat transfer fluid to cool the cargo it must be at a lower temperature than the cargo. This is not normally a problem, but for some cargoes the ideal temperature is as near to its critical point as is practical. If this is the case, you may set the heat transfer fluid temperature limit at 5°, this will allow the controller to deliver heat transfer fluid 5° lower than the set point. For heated cargoes a heat transfer fluid temperature limit of 5° will allow the controller to deliver heat transfer fluid at 5° above the set point. The setting is an “off set” limit on either side of the set point temperature, not an absolute temperature. In a case when it is not required or when the cargo will not be affected by sub-cooling or overheating, set the limit high. It is suggested, in this case, to leave the limit set at 15° or more. To set the limit, hold the glycol temp / set limit switch down while adjusting the touch pad as described above (creating a temperature set point page 14)

#### 1.9.6 Function Test of the Electronic Thermostat Assembly

To initiate the function test of the electronic thermostat, simply hold the test switch down “CLOSED POSITION” and turn the unit "ON". All the LED indicators will flash and the unit will proceed into the function test. When the test is completed the TCR-109 will continue to operate normally. A complete explanation of the function test can be found in paragraph 3.10.5.

After completion of the function test (approximately 1 min., 4 seconds) check the amperage of the compressor motor, condenser blower motor and heat transfer fluid pump. The maximum amp rating is on the electrical schematic.

Adjust the temperature set point to 0° C (32° F). Check the refrigerant level in the receiver sight glass after approximately 15 minutes of continuous running with the system fully loaded. Reset the required temperature and limit bandwidth.

## SECTION TWO - DETAILED FUNCTIONAL DESCRIPTION

### 2.1 Refrigeration System Operation

The TCR-109 refrigeration system is uncomplicated, easy to operate, and requires very little maintenance. Central in the TCR-109 is the scroll compressor, which represents the next generation in refrigeration technology and has several advantages over more conventional compressor styles. For example: the scroll form is designed to provide higher compression ratios than normally found in typical compressors. There is a dynamic discharge valve that provides improved energy efficiency when operating at higher compression ratios; a liquid injection system has been added to provide cooling to the compressor at low temperature operations; and also a Teflon impregnated bronze bearing in the compressor motor improves reliability. This type of compressor is suitable with the demanding applications that will be required of the TCR- 109.

The scroll is designed around two intermeshed and offset scrolls. One of these scrolls is orbital and the other one is fixed. The center of the orbiting scroll travels a circular path around the fixed scroll. This movement creates crescent shaped pockets between the two scroll elements. Low-pressure suction gas is trapped as each pocket is formed. Continued motion of the orbital scroll moves the gas pocket towards the center where maximum compression is reached and the discharge port is located.

The scroll compressor is hard-mounted to the TCR-109 frame. This is to prevent excessive external vibration in our ‘transport’ application, reducing maintenance of the system piping end connections. Vibration is further minimized by the design of the piping in the TCR-109, which allows transient vibration created by the compressor during start-up to dissipate without causing harm to the system.

The TCR-109 is capable of operation in all temperature ranges and with the added option of a heater assembly the cargo can be managed effectively and efficiently. An electronic thermostat controls the temperature of the product. See Section 3.10 for details of thermostat.

System components also include a coil condenser assembly with fan and motor to force airflow across the coils. A plate type heat exchanger which is the interface between the refrigeration system and the circulating system; a thermal expansion valve (TXV); filter-dryer and sight glass assembly are also included. There is a heat exchanger that allows any remaining refrigerant in a liquid state due to low temperature operations to convert to a gas prior to entering the compressor.

The safety systems included in the refrigeration system help to protect it from excessive pressures and temperatures and prevent operation of the compressor in a high vacuum condition. The system is equipped with high pressure control and the scroll compressor is fitted with an Internal Pressure Relief (IPR) valve. The compressor motor is fitted with conventional internal line break thermal protection. A discharge line thermostat is installed in the compressor control circuit. This thermostat has a cutout setting that does not allow the compressor temperature to reach unsafe levels. All of these controls will cause the motor protector to trip and shut down the compressor.

### 2.1.1 Liquid Injection System

The low temperature operation of the TCR-109, down to -40°C (-40°F), requires that a liquid injection system be used to aid in controlling the compressor temperature. The advantage of this system is that it tends to be self-regulating. As pressure increases in the scroll, the demand for liquid injection increases. Since more cooling is needed at high compression ratio conditions, this automatic increase in liquid is exactly what is needed. With liquid injection on the scroll compressor there is a loss of capacity or mass flow at the inner pocket injection point.

## 2.2 (Heat Transfer Fluid) Circulating System Operation

The circulating system is designed to be compatible with heat transfer fluids. The heat transfer fluid used in the system is decided mostly by its application. The circulating system consists of a close-coupled centrifugal pump and motor assembly, a relief valve, an expansion tank system, a plate-type heat exchanger and associated piping enabling connection to the tank container.

The pumped fluid lubricates the close-coupled pump assembly as it passes through the assembly. Maintenance is reduced on this unit by using sealed bearings and eliminating the alignment between pump and motor. The motor is rated at 0.5 horsepower and capable of handling fluids with temperatures of -40°C (-40°F).

The expansion tank system provides a place for the expansion of either the heat transfer fluid during temperature changes, or on a limited basis, acts as a storage area for some additional coolant.

The plate-type heat exchanger is the interface between the refrigeration system and the tank's cooling system. It is a 3-ton chiller made of a corrosion resistant metal and is maintenance free. Associated piping is included in the construction of the cooling system that will enable the operator to connect from the tank coil system to the TCR-109 using standard flexible hose connections. This connecting system can be adapted at the factory or in the field to fit many applications.

## 2.3 Pressure Controls and Safety Devices

The TCR-109 has incorporated many safety devices and protective controls that aid in preventing damage to the unit and the cargo being handled, adding also a measure of personal safety. The safety devices control the pressures and temperatures while the unit is operating.

High pressure is controlled by a pressure switch set to open at 31 bar (450psig) and close at 21 bar (300psig). This switch will signal the controller which de-energizes the compressor contactor to shut down the system preventing high-pressure damage.

As an aid to preventing too low of a condensing temperature, capacity is controlled in the scroll compressor. This is accomplished by using a discharge temperature control (DTC) valve that injects a controlled amount of refrigerant back into the compressor. A liquid injection system has been added to provide cooling to the compressor. An injection port is internally connected to an inner pocket of the scroll mechanism for liquid refrigerant injection. This pocket is separated from the suction inlet, so no loss of capacity or mass flow results from injecting at this point.

The DTC valve monitors the flow of liquid refrigerant into the injection port, based on the temperature of the thermal element located in the top cap thermal well of the compressor.

The scroll compressor is also equipped with an internal pressure relief (IPR) valve, which opens when the differential pressure from suction to outlet reaches an unacceptable limit. Opening this valve causes the motor protection to open and stop the compressor. This IPR valve prevents compressor over pressurization.

Installed in the compressor discharge line is a discharge line thermostat. This thermostat is designed to prevent the compressor from operating above its maximum discharge temperature. This thermostat will cut out the compressor and stop the motor, preventing burnout of the motor and damage to the scroll; it opens at 104°C (220°F) and closes at 77°C (170°F).

## SECTION THREE - GENERAL MAINTENANCE REQUIREMENTS

### 3.1 Pre-Trip Maintenance

Pre-trip maintenance is necessary for the operator to feel confident that the TCR-109 refrigeration system will perform adequate cargo handling. Pre-trip maintenance is simple to perform, and if conscientiously applied, will enhance the reliability of the unit. Routine pre-trip maintenance will also add to the service life of the unit. A hyperlink to access forms for pre-trip maintenance can be found in this manual at Section 5.9. It is suggested that the operator uses this form as the basis of an in-house quality control form customized for local circumstances reporting procedures etc. and translating them to the language of the mechanic, using the form.

### 3.2 Safety Precautions

**WARNING:** The refrigerant used in this system is heavier than air. It will collect at low levels and displace oxygen in confined areas. If you experience dizziness, shortness of breath, and have a sweet taste in your mouth, feel tired, or have nausea, remove yourself from the area immediately and seek medical attention. DO NOT continue working until the area is properly ventilated and you are cleared by medical personnel.

All service and maintenance procedures should be performed in accordance with local, city, and state, federal and national laws or ordinances or rules. Avoid discharge of refrigerant directly into the atmosphere.

When any work is to be performed on the components of the refrigeration system, always make sure that the equipment is electrically disconnected to avoid accidentally starting equipment when maintenance personnel are working. It is recommended that a lockout / tagout program be in place when performing maintenance on the unit.

A thorough study of the electrical diagram is recommended before any work should begin on the electrical system. Understanding the voltages present and the location of components within the electrical system can avoid the potential for a life-threatening injury.

Do not exert excessive pressure when tightening a flare nut assembly within the refrigeration pipe work. The flare could split and the refrigerant charge could be lost. Always use the "Two Wrench System" when applying pressure to a flare nut fitting when tightening.

Always wear the proper Personal Protective Equipment (PPE) when working on the system. Ensure that others around you wear PPE also. Goggles, face shields, and gloves should be available and used by the technician to avoid injury. Other PPE as required for the task should be readily available and used.

Caution must be used in any attempt to heat refrigerant. Avoid any application where heat is necessary to inject refrigerant into a system. Refrigerant is a highly pressurized gas or liquid and rapid expansion due to heating could be explosive and result in death.

Always secure or close the refrigerant tank valve after use. Install all caps and covers and do not allow the cylinder to be dropped or hit by objects. To prevent explosive damage to the tank neck and valve, be certain that the tank protective cap is on when moving.

Other than proper heating tools for refrigerant bottles, do not allow the refrigerant to come in contact with a flame-heated surface, flare, cigarette or any sort of heated object. When refrigerant is heated above 649° C (1200° F) it can produce a deadly gas, Phosgene, which is odorless and colorless and can cause death.

Be aware of your surroundings and work safely. Do not work from a height without proper equipment and safety measures in place. Do not allow people to stand below you or work above you. Tie off tools that may fall from a height and allow for a 3ft-(1m) drop. This should allow for plenty of freedom of movement.

A manifold gauge set should always be used to determine if the refrigerant charge has been removed. The manifold gauge set should also be used when charging the refrigerant system, checking a cylinder charge, performing routine maintenance or any other task that would require monitoring of pressures within the refrigeration system. Ensure that the manifold gauge set does not become contaminated with foreign substances. If suspected, clean the gauge set thoroughly before the next use.

### 3.2.1 Non-Condensable Gases

Air and non-condensable gases in any system gather in the receiver above the liquid. This will result in above normal discharge pressures. These gases can be removed during operation by purging through a valve provided for this purpose at the receiver. To purge, use recycle equipment and connect to purge valve. Open purge valve a small amount. Note any significant difference in the discharge pressure. Repeat this procedure until the discharge pressure is normal.

## 3.3 Checking and Adding Refrigerant Charge

The refrigerant charge should only be checked when the unit is operating at full load. Make sure the compressor is running loaded by observing that the refrigeration system temperature is at least 12°C below the outlet of the circulating system at the outlet of the chiller. If the temperatures cannot be verified set the thermostat at -9°C (16°F) and check to be sure compressor is loaded before checking charge.

The TCR-109 is charged with refrigerant at the factory. The nominal factory charge can be found on the unit data plate. A nominal charge for an ambient temperature of 32°C (90°F) is applied before shipment. At low ambient below 32°C (90°F) there may be some flashing or bubbles appearing in the sight glass. It should not be assumed that the unit is low on refrigerant. At low ambient temperatures, some of the refrigerant may "hide" in the coil assemblies. If this condition is present, it may be necessary to block the airflow access the coil assembly to raise discharge pressure. For a circulating system temperature of 2°C (35°F) the discharge pressure should be 375 +/- 10 psig, at -19°C (0°F) the discharge pressure should be 310 +/- 10 psig.



When the discharge pressures are as described, allow the unit to continue to operate for about 15 minutes allowing the system to stabilize. Check the sight glasses on the receiver. The ball(s) in the bottom sight glass should be floating continuously. The ball(s) in the upper sight glass should not be floating. It is important to have the proper charge of refrigerant in the system. Too much or too little refrigerant will reduce the cooling capacity of the system. Always determine the cause for low refrigerant in the system before adding more. It is recommended that a leak check be performed.

When adding refrigerant be sure to maintain discharge pressures as described in this section. Rapid charging of only the suction side of the scroll compressor can lead to a condition called "scroll lock" This is a no-start condition for the compressor. To avoid this condition, it is preferable to apply system charges from both the high- and low-pressure sides of the compressor at a rate that will prevent this condition from occurring.

To add small quantities of refrigerant to the system, it is preferable to add gas on the low-pressure side or suction side of the compressor. Accomplish this with the compressor operating. There will be little or no interference in the operation of the system. When determined that sufficient refrigerant has been charged into the system, check suction and discharge pressures for proper levels. Observe sight glass and receiver levels. If all is satisfactory, return unit to normal operating conditions.

### **3.4 Checking and Adding Refrigerant Oil**

The TCR-109 uses R-404A or R-452A refrigerant, only polyol ether can be provided to the scroll compressor. The only recommended lubricants are Klinge part number K11-00416-00, Copeland Ultra 22 CC, Mobil EAL Arctic 22 CC, or ICI EMKARATE RL 32CF. Use of any lubricant not recommended will render the warranty void.

**Note:** The TCR-109 has been factory set with the correct charge of oil. Normal use should not require additional oil.

The oil level in the scroll compressor should be maintained at the midpoint of the sight glass. Immediately after start-up of the compressor the oil level in the reservoir will fluctuate. It is advisable to monitor the oil level a few minutes after start-up to ensure that there is enough oil in the compressor. If the oil level is low, below the center of the sight glass, it will be necessary to add oil to the compressor. Normal oil level should be maintained at the mid-level of the sight glass.

### **3.5 Leak Detection**

There are two methods of leak detection that will be discussed in this manual. The first is testing with soap suds solution. This method will reveal large leaks and is sometimes a good method. However, because it will only detect large leaks it is not recommended for use when determining system tightness.

The second method of detecting leaks is by using an electronic leak detector. There are several models available and all perform the same basic function. They are capable of detecting very

small leaks and are also capable of determining system tightness. This type of leak detector is recommended when troubleshooting the system for refrigerant leaks.

### **3.6 Evacuating the Refrigeration System**

Do not use the scroll compressor as a vacuum pump to evacuate the system. It is not designed to operate in a high vacuum and excessive wear of the scroll will occur. Use a vacuum pump designed for the purpose, one that is capable of drawing 0.15 mm Hg or better to the part of the system that has been opened. Continue this until all moisture and air has been removed.

Whenever it is necessary to open the system for any reason, always take care to prevent the entrance of moisture or air into sections of the system. Air almost always contains moisture and can lead to reduced reliability and shorten the life of the unit.

### **3.7 Opening the System or Unbrazing Components**

If the refrigerant is removed from only the high side of the unit, it is possible for the scroll compressor to seal and prevent removal of refrigerant from the low-pressure side. It is important to remember to check both the high- and low-pressure sides for pressure before opening or unbrazing system components.

Whenever it is necessary to open a charged or functioning system to make repairs or replace component parts, it is necessary to comply with local, regional, federal, or government regulations or laws regarding the handling of refrigerant. It is recommended that recovery and recycle equipment be used when handling refrigerants.

Steps should be taken to prevent contamination of a brazed joint. Check the type of compound used to seal the joint. It is recommended that silver solder and flux be used where required for joining and sealing joints in the refrigeration system. Do not use soft solder to join or seal joints or leaks. Use of soft solder on the TCR- 109 piping systems will void the warranty.

### **3.8 Heat Transfer Fluid Circulating System**

The circulating system component of the TCR-109 is straightforward and simple to maintain. General maintenance consists of purging and venting and filling when operations require that it be done. Be sure that when handling heat transfer fluids there is adequate personal protective equipment and spill prevention in place. The circulating system is an open-air system that is to say that the system does act open to the atmosphere. An expansion tank system allows for the contraction and expansion of the fluid in the circulating system.

Air in the circulating system would promote corrosion, increase maintenance and decrease reliability. To aid in preventing air from being entrapped to the system there is an optional air purger installed that allows any trapped air to escape.

#### **3.8.1 Filling Circulating System**

First read Section 1.7.2 on cleaning the system.

There are two types of heat transfer fluid systems.

The closed pressurized system- See Section 5 for specific instructions.

The open system- With the vents open or even temporarily removed, additional liquid may be added directly to the expansion tank. Once the liquid can be seen in the plastic sight-glass the pump may be operated intermittently. Additional liquid may be added to the expansion tank. With a column of liquid in the vertical pipe from the expansion tank the pump will be self-priming but may quickly displace the volume in the vertical pipe. Stopping the pump, adding liquid to the expansion tank, re-running the pump for a few seconds, stopping it and adding more liquid may have to be repeated a number of times until liquid fills the majority of the system. Once this condition is achieved, the unit should be both self-priming and purge itself of entrapped air.

### 3.8.2 Air Purge and System Venting

The air purger has a small air chamber which holds air until it is manually vented through a Schrader type valve. This provides full-unrestricted port opening when systems are first filled, and fast, high volume venting is required. In combination with the air purge this will insure air separation for manual venting.

#### Schrader valve type

These small automotive tire type valves require any cover and cap to be removed and the center pin of the valve to be depressed as in a pneumatic tire. Always replace the stainless-steel cap and any outer cover.

## **3.9 Hi-Pot Testing**

Hi-Pot testing is done to determine if there is a significant increase in current leakage in motor windings. High current leakage can, in most cases, indicate a breakdown in motor insulation resistance.

Hi-Pot testing test of the motor will aid in determining current leakage. The motor is normally dry and free of contaminants that could increase the leakage rate. If a high current leakage is measured, it is possible that a failure of the motor is occurring.

### 3.9.1 Compressor Motor

Scroll compressors are configured with the motor in the bottom of the shell. It is likely that the scroll compressor will be immersed in refrigerant when liquid is present in the shell. Hi-Pot testing with liquid refrigerant in the shell can show higher leakage due to the conductivity of liquid refrigerant vapor and/or oil. To lower the current leakage reading, operate the system for a brief period of time – about ten minutes – and test again. There should be a reduction in the amount of current leakage.

### 3.9.2 Condenser Blower Motor

This totally enclosed motor is equipped with shielded ball bearings, which require no lubrication. The motor is designed to operate satisfactorily with line voltages, which are within 10% of nameplate values. The motor is protected by an automatic reset klixon, which is normally closed. In case of overheating, the klixon will open and the motor will stop.

**CAUTION:**

**Replacement blower motors may be manufactured for opposite rotation from what is required. Always check for proper rotation and, if required, reverse two of the three leads.**

### 3.9.3 Circulating Pump Motor

Hi-Pot Testing of the circulating pump motor will aid in detecting problems in the motor windings that could lead to failure of the circulating system. This motor is normally dry and free of contaminants that could increase leakage. If a high current leakage condition is measured, it could indicate a failure of the motor.

## 3.10 General Description Klinge Corporation Thermostat

This microprocessor device contains all components and software necessary to select those functions required to maintain an accurate temperature. The selection is based on signals received from the probes and the display panel. It is designed to operate in ambient temperatures of  $-40^{\circ}\text{C}$  ( $-40^{\circ}\text{F}$ ) to  $70^{\circ}\text{C}$  ( $158^{\circ}\text{F}$ ). It will control temperature settings (set point) of  $-29^{\circ}\text{C}$  ( $-20^{\circ}\text{F}$ ) to  $29^{\circ}\text{C}$  ( $84^{\circ}\text{F}$ ).

### 3.10.1 LED Indicators

The narrow edge of the thermostat contains a series of LEDs. These LEDs, in conjunction with the thermostat's labels serve a dual purpose.

1. The front thermostat label, with illuminated LED(s) indicates the operating status of the unit.
2. The side label is used for the function test. The lit LED indicates the function being tested.

### 3.10.2 Inputs

Input signals to the device consist of:

1. The heat transfer fluid and cargo temperature probe.
2. Set point (desired cargo setting).
3. Glycol limit setting (offset from set point).
4. Signal to function test from SW2.

### 3.10.3 Relays

Output signals from the device are by a means of (8) relays.

- (4) Relays are single pole single throw, normally open.
- (4) Relays are single pole double throw.

Outputs used in the system are:

1. Compressor ON (cooling)
2. Condenser blower ON.
3. Phase sensor ON. (Pump)
4. Optional heater.

Each output relay has a red LED mounted on the circuit board adjacent to the relay to indicate the relay is energized.

These LEDs are only visible from the side of the device and are for diagnostic purposes only.

#### 3.10.4.1 Temperature Falling

1. Compressor cycles off at set point.
2. If equipped, Heat cycles ON at 0.5°C (0.9°F) below set point.

These are inhibited if the heat transfer fluid temperature is outside the heat transfer fluid limit setting.

#### 3.10.4.2 Temperature Rising

1. Compressor cycles ON at 0.5°C (0.9°F) above set point.
2. There is a one-minute OFF delay of the compressor before it can cycle ON again, regardless of the temperature rise.
3. If equipped, Heat cycles OFF at set point.

#### 3.10.5 Function Test (Labels on the right side of the thermostat)

To initiate the function test hold the test switch (SW2) closed and switch unit ON/OFF switch to ON. The microprocessor will flash all LED indicators, let go of SW2 and then proceed through the function test. There are (7) steps in the function test. Depending on the configuration, all (7) may not be tested. The LED will light to indicate the function being tested and will flash if there is a problem.

The function test steps are as follows:

1. Energize phase contactor
2. Energize glycol pump
3. Energize condenser blower
4. Energize compressor
5. Energize heat (optional)
6. Not Used
7. Energize alarm horn
8. Check probes

#### 3.10.6 Other Functions

1. If the temperature pull-down rate is less than 0.05°C (0.1°F) per hour, the alarm LED will light and the temperature failure LED will flash. This function is locked out within +/- 2°C (3.6°F) of the set point.

2. After reaching the set point, if the temperature varies more than  $\pm 2^{\circ}\text{C}$  ( $3.6^{\circ}\text{F}$ ) for more than 120 minutes, the alarm LED will light and the temperature failure LED will light.
3. The alarm LED indicators are reset by turning the control system power OFF or by the temperature reaching the set point.

## **SECTION FOUR - TROUBLESHOOTING**

### **4.1 General Information**

This section is intended to aid the technician in determining the cause of a malfunction of the TCR-109. This section is as complete as possible, however, in troubleshooting it is not always possible to target every cause. The experience of the technician and this chapter should enable correction of a malfunction to the TCR-109.

### **4.2 Electronic Thermostat**

The thermostat is mostly solid state and therefore has a high degree of reliability.

If the controller is suspect first check:

1. That the probe is in close contact with the point being measured.
2. That the system has heat transfer fluid in it and has been vented.
3. That no external wires are loose or have been shorted out.
4. Undertake a function test.

The controller cannot be repaired or reprogrammed in the field but a core replacement price is offered for a unit returned that can be repaired. Contact Klinge Corporation for a replacement.

### **4.3 Refrigeration System**

The refrigeration system is relatively simple. Elements have been incorporated into the design that reduce maintenance and increase reliability. The result is also a system that is straightforward to troubleshoot. Most problems encountered in the refrigeration system can be found and corrected with minimum difficulty. Refer to Refrigeration Fault Logic Table for fault logic decisions for troubleshooting a malfunction.

### **4.4 Circulating System**

The circulating system is another straightforward system, simple in design and operation. As the system is designed as a closed system there is no requirement for an inline filter. If however, on initial charging of the system, or in service, the system is contaminated with solid matter it will collect at the chiller and restrict the flow and therefore the capacity of the system. If this happens the chiller may be reverse flushed with high pressure, high volume liquid such as wet steam.

The pump, being a moving part, has a service life estimated at 4 to 5 years of regular service in one way trade. There is a replacement kit available, which includes bearings and seals for in-service replacement.

Quote the serial number of the unit when ordering the in-service replacement kit.

Refer to the Circulating System Fault Logic Table for fault logic decisions for troubleshooting a malfunction.

### **4.5 Electrical System**

The electrical control system for the TCR-109 is rugged and compact. The technician is expected to have some knowledge of electrical applications related to refrigeration systems. An understanding of electrical drawings and schematics is also helpful. Refer to table below for the fault logic decisions for troubleshooting a malfunction.

## **ELECTRONIC THERMOSTAT FAULT LOGIC**

### **DURING FUNCTION TEST**

Use the label on the side of the thermostat

All LEDs flash

Step 1 Phase Test LED 3 illuminated

Step 2 Glycol Pump LED 4 illuminated

Step 3 Condenser Blower LED 5 illuminated

Step 4 Compressor LED 6 illuminated

Step 5 Heat (Optional) LED 7 illuminated

Step 6 "NOT USED" LED 8 illuminated

Step 7 Alarm Horn LED 9 illuminated

Step 8 Probes LED 10 illuminated

### **DURING OPERATION**

Use the label on the front edge of the thermostat



## REFRIGERATION SYSTEM FAULT LOGIC

Malfunction	Probable cause	Recommended corrective action
No power to the unit	Power plug not connected Source not operating Loose cable connections	Connect the power plug Verify that power source is operating Check cable connections
Unit will not start	Tripped CB1, CB2 or CB3 No secondary control voltage present at T1	Reset circuit breakers Check primary side of 460V AC. If no voltage present refer to "NO POWER TO UNIT" Check all electrical connections for tightness. Recheck primary voltage Replace defective T1
The compressor operates noisily	Flooded suction on start Faulty liquid injection valve Faulty current sensing relay Faulty capacity control pressure switch	Considered normal, check for reverse rotation of compressor if present Replace Replace Replace
Bubbles forming in sight glass	Low refrigerant charge	Check refrigerant level and charge
Oil level is low	Oil refrigeration leak Oil consumed during normal use	Leak check and evacuate the system Recharge oil to proper level in the compressor

<b>Malfunction</b>	<b>Probable Cause</b>	<b>Recommended corrective action</b>
Moisture indicator is “wet”	Non-condensable gas in the system	Remove non-condensable gases and check refrigerant charge
	Excessive moisture in the system	Evacuate, and leak check the system
Refrigerant charge is low	Leak in the system	Leak check and evacuate the system

### CIRCULATING SYSTEM FAULT LOGIC

<b>Malfunction</b>	<b>Probable cause</b>	<b>Recommended corrective Action</b>
Unit not cooling	Air trapped in the circulating system Or Low glycol in the system	Vent circulating system  Add additional cooling medium  Check to see if expansion tank is vented to atmosphere
Pump working but no flow	Cooling medium too viscose Or Air trapped in the circulating system.	Check concentration of cooling medium
The sight glass is not clear	Cooling medium contaminated	Test sample

## 4.6 Alarm Code

Alarm LED indicators are reset if control system power is turned OFF.

**Note:** If the display would display a “P” number, this indicates that you have accidentally entered the Configuration Menu. In order to prevent accidental changes please turn the unit off and back on.

ALARM CODE	ALARM NAME	ALARM CONDITION	ALARM CLEAR	SUGGESTION FOR REPAIR	ALARM LEVEL (HIGH = SYSTEM CHANGEVER)
A01	Glycol sensor short	The sensor or the wire to the sensor is shorted.	If there has not been an alarm for 60 minutes, then the alarm is cleared by the controller. Or by C/F key.	Replace sensor. Check wire for damage.	High
A02	Glycol sensor open	The sensor or the wire to the sensor is open.	If there has not been an alarm for 60 minutes, then the alarm is cleared by the controller. Or by C/F key.	Replace sensor. Check wire for damage.	High
A03	Cargo sensor short	The sensor or the wire to the sensor is shorted.	If there has not been an alarm for 60 minutes, then the alarm is cleared by the controller. Or by C/F key.	Replace sensor Check wire for damage.	High
A04	Cargo sensor open	The sensor or the wire to the sensor is shorted.	If there has not been an alarm for 60 minutes, then the alarm is cleared by the controller. Or by C/F key.	Replace sensor Check wire for damage.	High
A05	Heater sensor short	The sensor or the wire to the sensor is shorted.	If there has not been an alarm for 60 minutes, then the alarm is cleared by the controller. Or by C/F key.	Replace sensor Check wire for damage.	High
A06	Heater sensor open	The sensor or the wire to the sensor is open.	No action.	Replace sensor Check wire for damage.	High
A07	Compressor sensor short	The sensor or the wire to the sensor is shorted.	If there has not been an alarm for 60 minutes, then the alarm is cleared by the controller. Or by C/F key.	Replace sensor Check wire for damage.	High
A08	Compressor sensor open	The sensor or the wire to the sensor is open.	No action.	Replace sensor Check wire for damage.	High
A09	Pressure transmitter out of range.	The sensor or the wire to the sensor is defective.	If there is a pressure transmitter on the unit, then the alarm is cleared by display C/F key. Else no action.	Replace sensor Check wire for damage.	Low

A11	Phase sensor fail	The sensor cannot find the 3 phase at the main power. (Test is performed at unit start up)	If the sensor passes a new test, then the alarm is cleared by the controller. Or by C/F key.	Check Main power Check glycol pump. Check condenser Fan. Check CT sensor. Check wire for damage.	High
A12	Low current on heat element	The heat element is using too little power. (Test is performed at unit start up)	The alarm is cleared by display C/F key	Check if relay is switched on. Check output from controller.	Low
A13	High current on heat element	The heat element is using too much power. (Test is performed at unit start up)	The alarm is cleared by display C/F key	Check if relay is switched on. Check output from controller.	Low
A14	Low current on pump motor	The pump motor is using too little power. (Test is performed at unit start up)	The alarm is cleared by display C/F key	Check if relay is switched on. Check output from controller.	Low
A15	High current on pump motor	The pump motor is using too much power. (Test is performed at unit start up)	The alarm is cleared by display C/F key	Check amps at pump motor. Check if pump is rotating.	Low
A16	Low current on condenser fan	The condenser fan is using too little power. (Test is performed at unit start up)	The alarm is cleared by display C/F key	Check if relay is switched on. Check output from controller.	Low
A17	High current on condenser fan	The condenser fan is using too much power. (Test is performed at unit start up)	The alarm is cleared by display C/F key	Check amps at condenser motor. Check if fan is rotating.	Low
A18	Low current on compressor	The compressor is using too little power. (Test is performed at unit start up)	If there has not been an alarm for 60 minutes, then the alarm is cleared by the controller. Or by C/F key.	Check if relay is switched on. Check overload relay. Check output from controller. Check gas at the ref. system. Check if HP is switched out.	Low
A19	High current on compressor	The compressor is using too much power. (Test is performed at unit start up)	If there has not been an alarm for 60 minutes, then the alarm is cleared by the controller. Or by C/F key.	Check amps at compressor motor.	Low

A20	Different current on heat element	There is a difference between the phases. (Test is performed at unit start up)	The alarm is cleared by display C/F key	Check if relay is missing a phase. Check if voltage is too low. Check the motor element for defect with a clamp ammeter	Low
A21	Different current on pump motor	There is a difference between the phases. (Test is performed at unit start up)	The alarm is cleared by display C/F key	Check if relay is missing a phase. Check if voltage is too low. Check the motor element for defect with a clamp ammeter	Low
A22	Different current on condenser fan	There is a difference between the phases. (Test is performed at unit start up)	The alarm is cleared by display C/F key	Check if relay is missing a phase. Check if voltage is too low. Check the motor element for defect with a clamp ammeter	Low
A23	Different current on compressor	There is a difference between the phases. (Test is performed at unit start up)	If there has not been an alarm for 60 minutes, then the alarm is cleared by the controller. Or by C/F key.	Check if relay is missing a phase. Check if voltage is too low. Check the motor element for defect with a clamp ammeter	Low
A28	Float switch failure	The float switch has been activated	If there has not been an alarm for 60 minutes, then the alarm is cleared by the controller. Or by C/F key.	Check glycol level, it is most likely low and needs to be topped off.	High
A29	Temperature sensor difference too large under test.	Difference between the temperature sensors is too large. (Test is performed at unit function test)	The alarm is cleared by display C/F key	Check sensors for correct reading.	Low

A30	Container temperature too low	<p>If the rate of temperature change is too slow, less than 0.06 °C / hour, (i.e. Not heating fast enough) and the cargo probe temperature is outside of a 2°C window of the set point there is an alarm.</p> <p>OR if the cargo probe temperature has been inside a 2 °C window of set point at some time since power up or since the set point was changed, and if the glycol temperature is outside a 2°C window of set point for 2 hours or more, there is an alarm.</p>	<p>If the return air is inside the 2°C window of the set point, then the alarm is cleared by the controller.</p> <p>Or by C/F key.</p>	<p>Check sensors for correct reading. If unit is equipped for heat ensure heater is functioning properly.</p>	High
A31	Container temperature too high	<p>If the rate of temperature change is too slow, less than 0.06 °C / hour, (i.e. Not cooling fast enough) and the cargo probe temperature is outside of a 2°C window of the set point there is an alarm.</p> <p>OR if the cargo probe temperature has been inside a 2 °C window of set point at some time since power up or since the set point was changed, and if the cargo temp is outside a 2°C window of set point for 2 hours or more, there is an alarm.</p>	<p>If the return air is inside the 2°C window of the set point, then the alarm is cleared by the controller.</p> <p>Or by C/F key.</p>	<p>Check refrigerant gas. Check TX valve. Check glycol pump motor. Check glycol flow. Check compressor. Check if condenser is dirty. Check condenser fan motor.</p>	High
A34	Compressor temp too high	<p>If the compressor sensor is above 120°C</p>	<p>If there has not been an alarm for 60 minutes, then the alarm is cleared by the controller.</p> <p>Or by C/F key.</p>	<p>Check refrigerant gas. Check if there is air in the refrigeration system. Check if condenser is dirty. Check condenser fan motor.</p>	High
A35	Temperature Fault	<p>These conditions will produce an open at terminal 31.</p> <p>If terminal 31 has been open in 60 minutes, then the alarm is set.</p>	<p>The alarm is clear by display C/F key</p>	<p>Check setting of temperature alarm recorder. Check glycol pump motor. Check gas on system. Check TX valve.</p>	High

A36	High pressure cut out. Cool mode	If there has been 3 HP cut out in an hour when the unit is in cool mode, then the alarm will be set to on.	The alarm is clear by display C/F key	Check condenser fan motor is running. Check if condenser needs cleaning. Check if there is air in the gas system. Check adjustment of suction regulator valve. Check HP switch for fault.	High
A41***	Set point different Sys 1/Sys 2	If the systems have set points 1°C or greater difference, the alarm is set.	The alarm is cleared when system set points are made less than 1°C different.	Check both system set points, and make equal.	Low
A42***	No response from other unit	If a signal is not received between the 2 systems for a time of 3 minutes the alarm is set.	The alarm is cleared when a signal is received between both systems.	Check connection of Can Bus cable.	Low
A43	Heat element temperature too high	Heater core probe has exceeded its safety limit.	The alarm is clear by display C/F key	Ensure proper glycol level in system.	Low
A49	Set point missing.	If set point is not loaded in controller, then the display will show -45	The alarm is clear by putting set point in controller.	This is normally if new software is uploaded to the controller.	High

\*\*\* Alarm codes A41 and A42 will only be applicable when 2 TCR-109's are assembled to one container, as a redundant system.

- **Low Level** A Low-Level Alarm will give the Alarm Number on the Touch Pad. The alarm lamp will light. The horn will not sound.
- **High Level** A High-Level Alarm will give the Alarm Number on the Touch Pad. The alarm lamp will light and the horn will sound. If the container is equipped with two TCR-109 units as a dual system, the control logic will automatically switch operation to the backup system.

## **SECTION FIVE - OPTIONAL PRESSURE CIRCULATING SYSTEM**

### **5.1 Pressurized Circulating Heat Transfer Fluid System**

On this model the heat transfer fluid system is a closed, pressurized system, that is, the heat transfer fluid is not exposed to the air. This is accomplished by using a buffer tank with a bladder to allow for the expansion and contraction of the heat transfer fluid as the temperature changes. No external air should get into the system, as would be the case with an atmospheric expansion tank. A small amount of gas will be induced into the system as the pump “cavitates”, but most will reabsorb as it passes through the pressurized pipe work.

Usually the coolant is an industrial heat transfer fluid. It is water-soluble, and has built-in corrosion inhibitors and is compatible with other heat transfer fluids of the same type. The combination of the closed system and corrosion inhibitors in the heat transfer fluid, permit the use of heat transfer fluid for many years without changing.

Air in the system would promote corrosion. This could cause noisy inefficient operations and energy waste. The result would be loss of pump performance and over time corrosion of equipment.

Major components of the system are the pump, the chiller, the air separator and vent, and the expansion tank, plus the piping system around the tank.

Built into the system are numerous vent points.

### **5.2 Air Trap and Vent**

The air separator has an air trap and Schrader “tire type” valve vent. This provides a port to expel air, but it has to be operated manually. The air separator has a small air chamber, which holds air until it is manually vented through a Schrader type valve. Usually the valve cap protrudes just above the insulation.

Venting at this location should be done at each pre-trip inspection.

Depending on the tank’s cooling system there may be additional vent points at the upper runs of the cooling system. Klinge suggests that they are fitted to the tank’s pipe work but are not always notified of the details.

(see 5.6 Air Blockage for more information on the importance of venting)

### **5.3 Filling the Heat Transfer Fluid System**

The expansion tank should be mounted at the top of the tank.

Heat transfer fluid is added through the fill valve located on the end of the expansion tank. There is a 5/8<sup>th</sup> -inch male flare fitting there for this purpose. The fill valve will only permit 12 psig in the heat transfer fluid system. To open the valve will require a pressure of 20 psig or more.



The circulating system is simple in design and operation. As the pipe work is designed as a closed system there is no requirement for an inline filter. If however, on initial charging of the system, or in service, the system is contaminated with solid matter it will collect at the chiller and restrict the flow and therefore the capacity of the system. If this happens the chiller may be reverse flushed with high pressure, high volume liquid such as wet steam.

The filling point on top of the expansion tank can be used for the initial fill, but because the air vent valve is so small, it can take a long time to expel all the air. For the initial fill it may be expedient to break the pipe work at one or two points to add the initial charge of heat transfer fluid by gravity and allow the air to escape at another point.

The pump is not self-priming and relies on the coolant as a lubricant, so should not be run dry. However, it may be run intermittently in the initial filling stage to assist in venting the system.

Because each system is different, the volume of the cooling system is not known to Klinge Corporation, however, generally the volume of heat transfer fluid for these units, when fitted on a 20,000 liter ISO tank, would be 30 ~ 40 or more US gallons. We recommend that for a new installation or a repair after a catastrophic loss that an economic unit such as a 25 US gallon barrel of pre-diluted transfer fluid is used.

**Note: Some type of pumping device will be required for this operation.**

Remove the Schrader valve cap and press the valve repeatedly during the filling operation. Put as much of the heat transfer fluid solution in the system as possible before running the machine. Run the unit's heat transfer fluid pump to circulate heat transfer fluid and remove air. Add more heat transfer fluid while the pump is running. To run the pump alone, set the thermostat temperature above the temperature of the heat transfer fluid so that the compressor will not run.

**Note: If there is no heater on the unit, the temperature will not rise significantly, but it will rise somewhat due to the mechanical energy induced by the pump.**

After the pump has been running, observe the heat transfer fluid through the translucent hose at the pump suction inlet. There should be very few air bubbles in the system when the system is full. When the system appears to be full, (no bubbles) continue to run the pump for approximately 15 minutes. Observe the heat transfer fluid during this period. The heat transfer fluid flow should be steady during this period.

Run the unit on cooling for more than 1 hour – the heat transfer fluid pipe from the chiller should be noticeably cooler. The refrigeration pipe at the expansion valve may frost up. This is normal, however, excessive icing indicates either a blockage in the chiller (see above on keeping the pipes clean) or that there is no heat transfer fluid flow for another reason (see 5.6 Air Blockage).

Cargo type permitting, set the thermostat to -29°C (-20°F). As the temperature falls, and when it nears the set point, check the translucent hose for bubbles and add more heat transfer fluid if necessary.

If the tank is loaded with a product, it may not be possible to pull the heat transfer fluid down to -29°C -20°F. In this case, pull the unit down until the pull-down rate slows down. Check for bubbles and add heat transfer fluid if necessary.

Replace the vent cap.

## **5.4 The Expansion Tank Charge**

The bladder in the expansion tank has air or nitrogen (N<sub>2</sub>) on one side and system heat transfer fluid on the other side. The gas side is to be adjusted to 0.8 Bar (12 psig). The system is designed to maintain this pressure of 0.8 Bar (12 psig).

This is a pre-set charge and is not normally adjusted, if for any reason it is suspected that the charge has been lost or the bladder ruptured contact Klinge Corporation on email [engineering@klingecorp.com](mailto:engineering@klingecorp.com) for specific directions.

### **5.4.1 The safety valve**

The system also has a safety pressure relief valve, external to the TCR-109 unit, set at 3.5 Bar (50 psig).

## **5.5 The Pump**

The pump is not self-priming and relies on the heat transfer fluid as a lubricant, so should not be run dry. However, it may be run intermittently in the initial filling stage to assist in venting the system.

## **5.6 Air Blockage**

A small amount of air trapped in the system may freely flow around the system in a pattern of small bubbles. These will be visible at the sight-glass. These bubbles will tend to be trapped in the air vent cavity at the air separator. They can be released by removing the cap and depressing the pin on the Schrader valve. Always remember to replace the Schrader valve cap.

Venting of this type should be done at each pre-trip.

The heat transfer fluid becomes denser and more viscous as the temperature falls and the entrapped air bubbles will tend to reduce in size. As the heat transfer fluid temperature falls, the bubbles will come out of suspension and have a tendency to collect and combine into one larger bubble. This will tend to happen at the lowest pressure point in the system normally at the top of the pipe run or at a change in pipe cross section, one that causes a pressure drop. Once developed in one of these traps, the large bubble will tend to accumulate all of the air in the system. When the volume of the air bubble exceeds the cross section of the pipe, it will tend to act as a pneumatic spring holding up the column of liquid on the suction side of the pump and stall the pump, resulting in no flow of liquid. Obviously, this large bubble cannot be seen from the outside of the system and the small bubbles seen in the sight glass may give the impression of liquid flow. The refrigeration unit will give the impression of working but the cargo temperature will rise. If this happens, there may be a frost build-up on the expansion valve at the chiller. To free the system of the residual bubbles the temperature of the heat transfer fluid may have to be elevated. Because of the comparative large mass of the cargo compared to the mass of the heat transfer fluid of a loaded container, it may be possible to lift the temperature of the heat transfer fluid without affecting the cargo temperature. If this is done, vent the air trap frequently. On completion, do not forget to replace the valve cap.

**Importance of removing air.** Air can not get into the system in normal operations, but in abnormal conditions air may be sucked in on the low pressure side or be generated by cavitation in the pump. Air should be removed as it will promote corrosion and could get trapped and create an airlock blocking the flow of heat transfer fluid. An air lock would be noisy, inefficient and waste energy. The result would be a loss of pump performance and corrosion of the equipment.

## **5.7 Charging Steps Checklist for a Closed Pressurized System**

(see detail on Section 5.8)

### **INITIAL FILL**

- 1 Begin with the system open (no pressure).
- 2 Open all vents slightly and begin adding heat transfer fluid at the lowest point. The air will escape as the heat transfer fluid fills. Closing each vent as the heat transfer fluid fills to that valve.
- 3 When the unit has been filled with heat transfer fluid, close the valves.
- 4 If the fill valve connected to the expansion tank is used, pressure of 1.4 Bar (20 psig) will be needed to push open the internal valve and push the heat transfer fluid into the system.

NOTE: The heat transfer fluid will only flow into the system using this valve, not into the expansion tank.

- 5 Turn the unit ON and adjust the set point to the same as the cargo temperature shown on the display (run only the pump). There will most likely be air trapped in the container piping. Continue venting at the plugs or valves on the container piping, with the pump running, to clear the pockets of trapped air tank pipe work (this may take some time).
- 6 Check the clear sight tube on the pump inlet, there should only be very small bubbles of air.
- 7 Check all the plugs and valves for leaks.
- 8 Set the thermostat to a lower temperature and check for cooling and vent the air separator Schrader valve to remove accumulated air. As the tank cools it may be possible to add more heat transfer fluid.
- 9 After the system sets idle overnight we suggest it be checked to remove air that may have moved to the vent points. Check all the plugs and valves for leaks and pump sight tube for air bubbles.

### **ADDING HEAT TRANSFER FLUID TO A CLOSED SYSTEM**

- 1 There is a fill / drain connection, a 1/4 turn valve, in the pump inlet line, external to the TCR-109 unit that can be used to add heat transfer fluid under pressure (see page 38).

Take care not to add air into the system; the valve can be slightly opened to fill the hose with heat transfer fluid before making the connection. If all the air has not been removed from the system it will compress and prevent the addition of heat transfer fluid.

2 Heat transfer fluid could also be added at any of the vent valves.

3 Also the fill valve above the expansion tank can be used to add heat transfer fluid with pressure of 1.4 bar [20 PSI]. This fill valve has a check valve and will prevent heat transfer fluid from flowing out.

NOTE: The fill valve will close when the bladder begins to be compressed.

## 5.8 Filling the Glycol Pressure System and Venting the Air

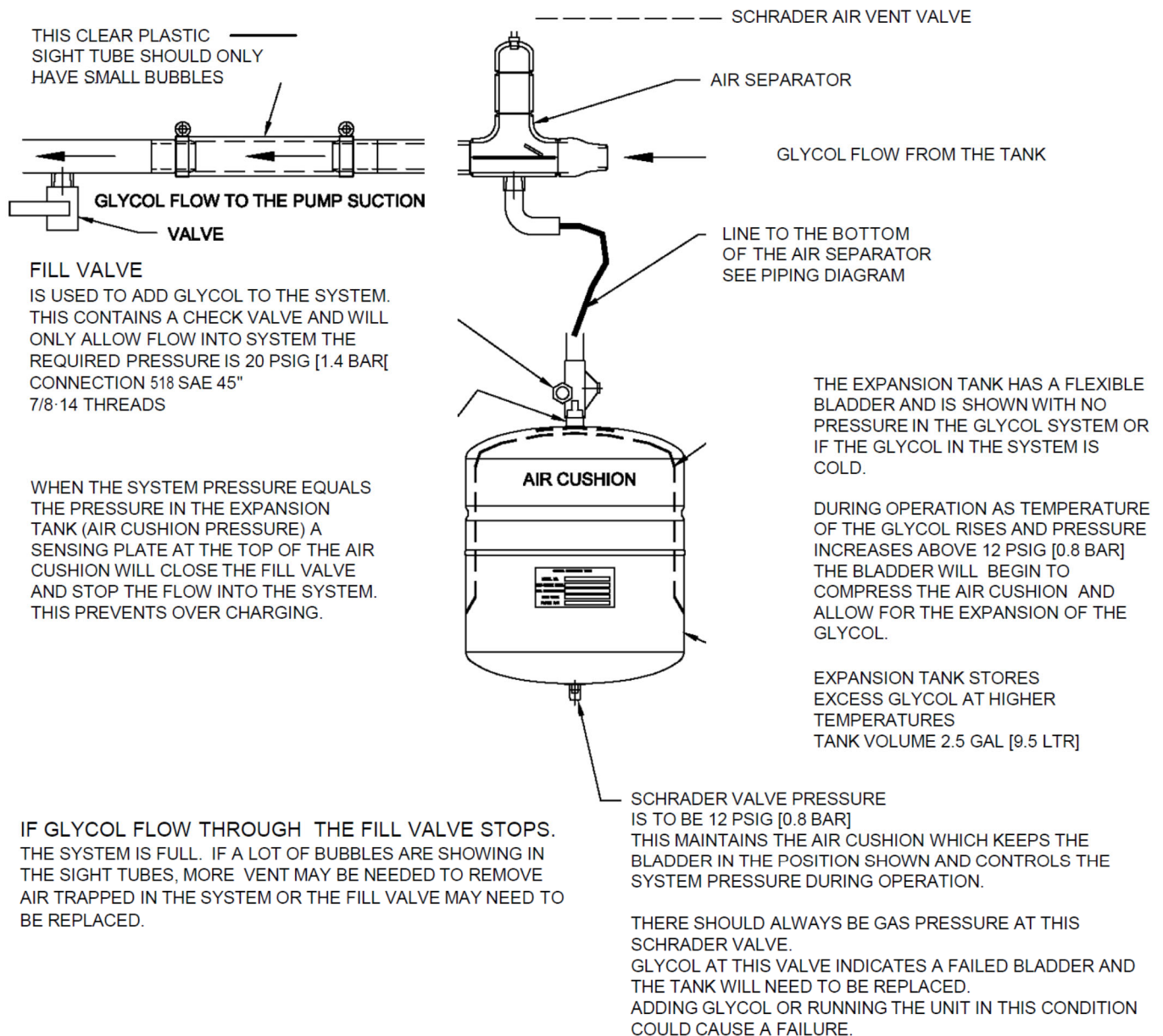

## 5.9 PTI Form

It is important that a Pre-Trip Inspection (PTI) be completed prior to each shipment.

The TCR-109 PTI form, for either Pressurized or Non-Pressurized systems can be found on Klinge's website at: <http://www.klingecorp.com/pti/>.

## SECTION SIX - INSPECTION AND REPAIR

### 6.1 Compressor

#### 6.1.1 Compressor Motor Protection

The compressor motor of the TCR-109 is equipped with an internal overload device. This device will stop the compressor if a problem arises which causes the motor to overheat. When the motor cools sufficiently, the overload will reset automatically.

#### 6.1.2 Compressor Lubrication

The compressor in the TCR-109 is a scroll compressor and operates only in one direction. In order to check the oil level in the compressor, a sight glass is provided in the front of the shell, allowing the oil inside the crankcase to be visible at all times.

Since the oil level will vary with operating conditions, it should only be checked after the compressor has been running long enough for the crankcase to warm up to operating conditions.

#### 6.1.3 Adding Oil

**Caution: This unit uses R-404A or R-452A refrigerant. Therefore, mineral oil type lubricant cannot be used.**

**The only oil approved by the manufacturer is Polyol ester lubricant, Klinge Part Number K11-00416-00, Copeland Ultra 22 cc, Mobile EAL Arctic 22cc, or ICI EMKARATE RL 32 CF.**

**The use of any lubricant not recommended by the manufacturer will render the warranty void.**

#### 6.1.4 Compressor Motor Burnout

**Caution: Acids are formed during motor burnout. Use rubber gloves and eye protection when working on the system or handling contaminated parts.**

When a hermetic motor burnout occurs, the stator winding insulation decomposes forming carbon, water and acid. To prevent contamination of the refrigerant system and repeat motor failures, definite steps **MUST** be taken to ensure the refrigerant circuit is kept clean from contamination.

**Damage to a compressor caused by failure to clean the system properly after burnout constitutes abuse and is not covered by the terms of the warranty.**

### 6.1.5 System Cleaning Procedure After Hermetic Motor Burnout

A hermetic motor burnout failure can be detected by observing an obvious electrical fault or by a strong burnt odor to the refrigeration gas released at the discharge valve port. After a motor burnout, the following procedure must be followed to clean the system and thus prevent failure of a replacement compressor.

Flushing out a refrigeration system with R-11 should not be considered. Scientific evidence has linked ozone depletion to R-11 emissions. In case of a motor burnout, Copeland recommends the filter drier cleaning procedure. Basically, this involves the use of approved filter driers incorporated with an adequate desiccant (not a filter only) in both the liquid and suction lines.

If there is no suction line filter and it is difficult to install a suction line filter, it is permissible to use a liquid line filter. However, in step 9 (below), instead of removing the suction line filter drier, inspect the compressor suction strainer and clean if necessary.

The filter drier procedure has been proven to be very economical, especially when the refrigerant in the system is recovered using safe recovery techniques. This can be easily accomplished if the compressor is fitted with service valves.

1. Recover refrigerant from the system. Remove the inoperative compressor and install the replacement.
2. Since the normal color of refrigerant oil varies from oil to oil, take a sample of oil from the replacement compressor and seal in a small bottle for comparison purposes after the cleaning operation is complete. Suitable 2 oz. bottles are easily obtainable.
3. Inspect all system controls such as expansion valve and solenoid valve. Clean or replace if necessary. Remove or replace any filter driers previously installed in the system, and clean or replace any filters or strainers.
4. Install the recommended size remote filter drier in the suction line and an oversized filter drier in the liquid line.
5. Evacuate the system.
6. Charge through the remote filter drier with the refrigerant, which was removed and recovered. Add additional refrigerant if necessary.
7. Start the compressor and put the system in operation. After (4) hours, stop the unit and replace the filter driers.
8. After completion of step 7, allow the unit to operate for 48 hours. Check the odor (**smell cautiously**) and compare the color of the oil with the sample taken in step 2. If an acid test kit is available, test for acid content. If the oil is discolored and smells acidic, or if the moisture indicator indicates a high moisture content in the system, change the filter driers. The compressor oil can be changed if considered desirable. Allow the system to operate for an additional 48 hours and recheck as before. Repeat until the oil remains clean, odor free and the color approaches that of the original sample.
9. Replace the liquid line filter drier with one of the normally recommended size. Remove the suction line filter drier.
10. After the cleaning procedure is complete, recheck in approximately two weeks to ensure that the system condition and operation is completely satisfactory.

## 6.2 Condenser Blower Motor and Heat Transfer Fluid Pump Motor

**Caution: Replacement motors may be manufactured for opposite rotation from what is required. Always check for proper rotation, and if required, reverse two leads.**

### 6.2.1 Condenser Blower

The motor and power cord connections are sealed with a watertight potting compound or silicone; no adjustments can be made here. **Caution:** Do not cut the cable short.

If the motor fan has to be removed from the motor shaft for any reason, be sure that the blower wheel is installed with the hub on the motor side. This wheel has forward curved blades.

Install the wheel on the assembly but do not tighten the cap screws holding the motor to the motor mount.

Extreme care must be taken to align the blower wheel and the inlet ring to be concentric and to have the wheel centered between the two inlet rings.

When all alignments are made, secure the assembly by tightening the motor mount cap screws. Attach the power wires and check for rotation. After the replacement has been made and the assembly put in place, pull the access cable into the compressor area. Coil and secure the excess cable.

### 6.2.2 Pump Assembly

These procedures are the same to replace the pump motor seal or the pump seal.

The heat transfer fluid connections will need to be removed for servicing the motor or the pump. The pump suction has a 1 ¼ NPT pipe connection; this is removed through the hole in the right side of the unit. The pump discharge has a 1in. NPT pipe connection and is accessible through the compressor area. There is a pipe coupling with a neoprene gland held together with two bolts and nuts inside the insulation. This insulation will need to be replaced after service.

The motor and power cord connections are sealed with a watertight potting compound or silicone; no adjustments can be made here. **Caution:** Do not cut the cable short.

Attach the power cable and check for rotation. The rotation should be clockwise, to the right facing the motor fan.

## 6.3 Filter Drier Replacement

This system is a closed system with all the joints brazed. The drier is not replaceable without evacuating the system.

To replace the drier:

Attach a manifold gauge set to the suction valve service Schrader port. The refrigerant recovery line is to be fastened to the manifold gauge. This line will be used to evacuate the system and perhaps add refrigerant.

## 6.4 High Pressure Switch



The high-pressure switch functions automatically to open or close the contactor coil circuit upon increase or decrease in discharge pressure.

To replace a pressure switch:

1. A Schrader valve is installed to prevent loss of refrigerant when removing the switch.
2. The cable should not be cut. The wire is to be sealed outside of the junction box.

## 6.5 Thermal Expansion Valve

The thermal expansion valve automatically maintains superheat of the refrigerant gas leaving the chiller. The only maintenance that the valve may require is to check that the bulb is making good contact with the suction line. The thermal bulb is secured at a pre-selected point on the suction line positioned between 4 and 5 o'clock, by a perforated metal strap. If, for any reason, this bulb is removed from the suction line, care must be taken to ensure that the bulb is correctly replaced and insulated. Ensure the bulb is properly insulated to prevent surrounding air from contacting the bulb.

**Note:** If the body has to be changed for any reason, it is not necessary to disassemble the new TX valve, but use extreme care to prevent warping of the new valve body due to excess heat being applied during brazing. To prevent warping, it is necessary to use wet rags to reduce heat buildup of the valve body. Direct the torch tip away from the body.

### 6.5.1 Replacement of Defective Thermostat Element

The only part of the thermal expansion valve that might fail is the power element. The power element can be easily changed.

1. Before removing the power element, the refrigerant must be removed from the system. To do this follow the steps under drier replacement.
2. Remove the power element bulb from the suction line and unscrew the power element. When removing the element check to be sure the push rods are in place and have not fallen out.
3. Install the new element hand tight. After hand tight, turn element clockwise 60° (movement equal to one hex flat).

### 6.5.2 Expansion Valve Adjustment

The expansion valve is set and tested at the factory before shipping. When the application or operating conditions require a different setting, the valve may be adjusted to obtain the required operating superheat. The expansion valve adjustment is capped for protection.

Remove the protective cap. To reduce the superheat, turn the adjustment stem counter-clockwise or to the left. To increase, turn the adjustment stem clockwise or to the right.

Only make one full turn at a time. It may take approximately 30 minutes after each adjustment before a new balance can be acquired.

1. Measure the temperature of suction line at the point the bulb is clamped.
2. Obtain the suction pressure that exists in the suction line at the bulb by either of the following methods:

- a. If the valve is externally equalized, a gauge in the external equalizer line will indicate the desired pressure directly and accurately.
  - b. Read the gauge at the suction valve of the compressor. To the pressure add the estimated pressure drop through the suction line between bulb location and compressor suction valve. The sum of the gauge reading and the estimated pressure drop will equal the approximate pressure at the bulb.
3. Convert the pressure obtained in 2a and 2b to saturated temperature, based on the refrigerant, by using a Temperature/Pressure chart.
  4. Subtract the two temperatures obtained in 1 and 3, the difference is the superheat.

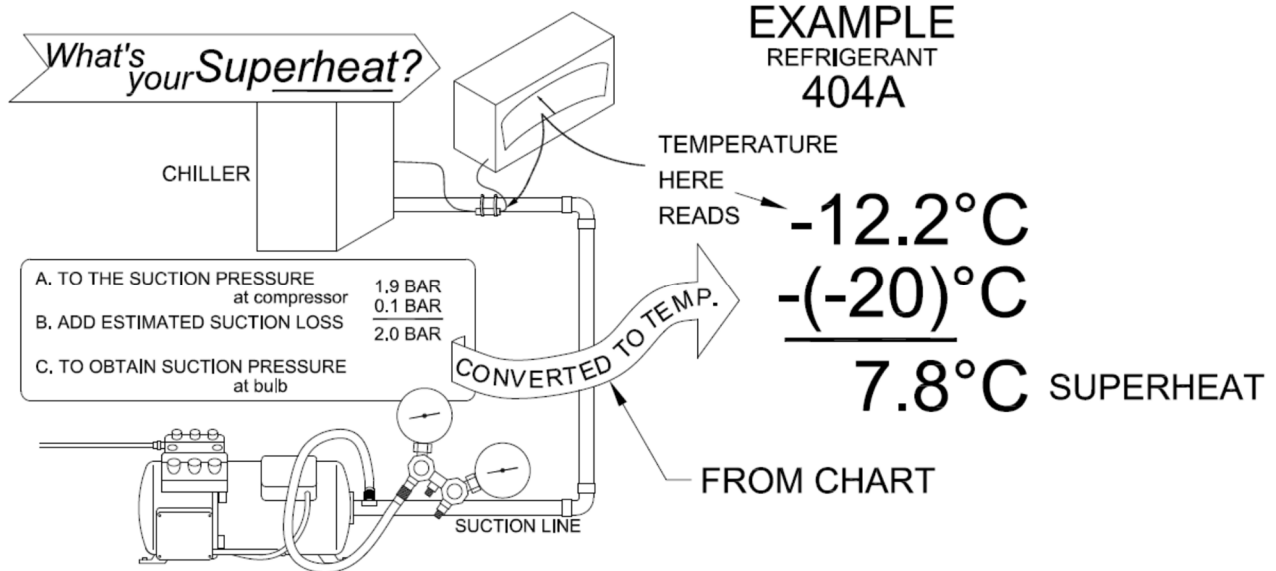

# 6.6 Electrical Schematic

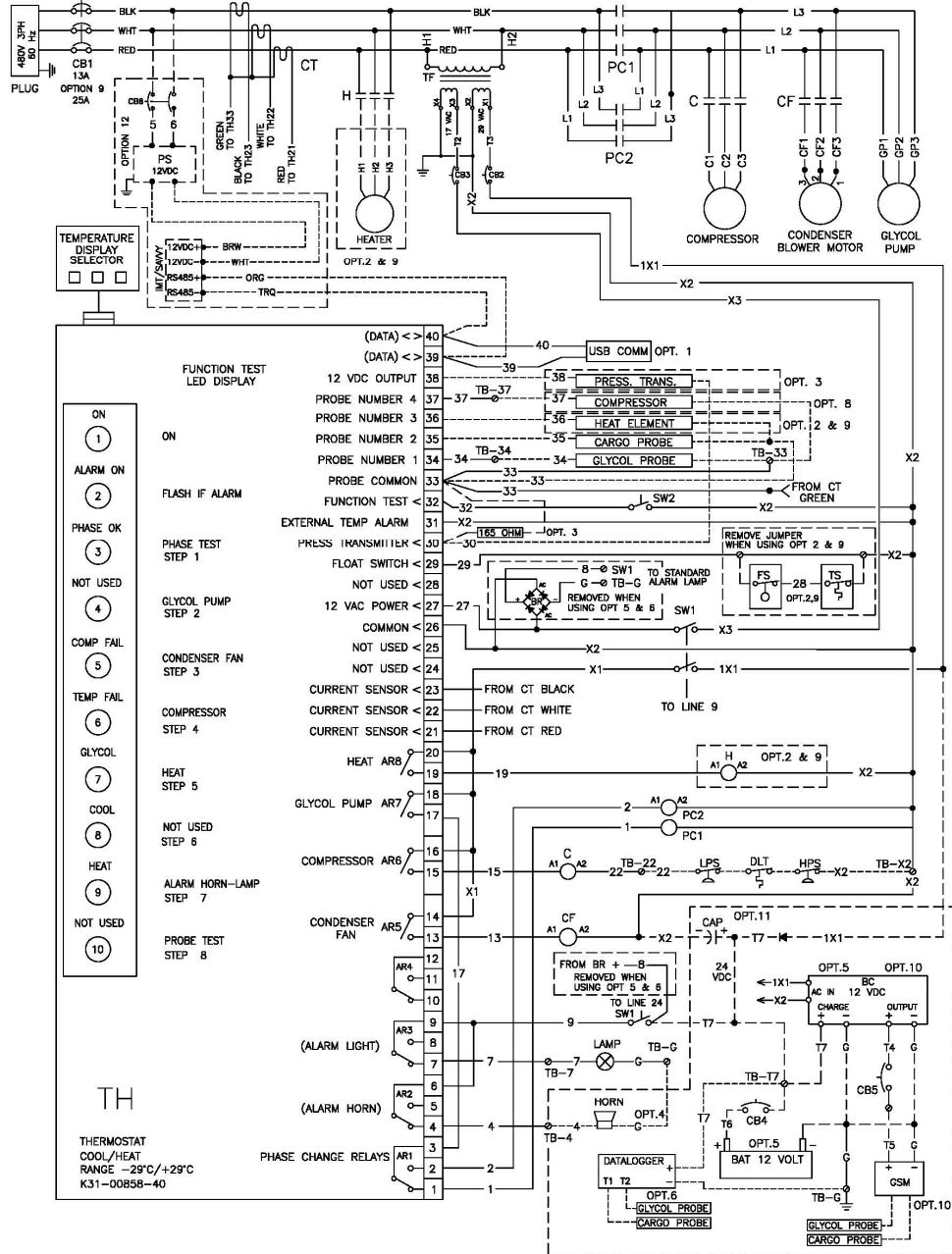

### LEGEND

- |                                      |                                      |
|--------------------------------------|--------------------------------------|
| C COMPRESSOR CONTACTOR               | FS LOW LIQUID LEVEL FLOAT SWITCH     |
| CB1 CIRCUIT BREAKER (MAIN POWER)     | PC1 PHASE CHANGING CONTACTOR NO.1    |
| CB2 CIRCUIT BREAKER 4A (24VAC)       | PC2 PHASE CHANGING CONTACTOR NO.2    |
| CB3 CIRCUIT BREAKER 4A (12VAC)       | SW1 UNIT ON/OFF (3P)                 |
| CB4 CIRCUIT BREAKER 4A (12VDC)       | SW2 FUNCTION TEST / SET LIMIT SWITCH |
| CB5 CIRCUIT BREAKER 3A (12VDC)       | TF TRANSFORMER 480 - 17/29 VAC       |
| CF CONDENSER FAN CONTACTOR           | TB TERMINAL BLOCK IN ELECT. BOX      |
| CT CURRENT TRANSFORMER (PHASE 1-2-3) | TH THERMOSTAT (MICROPROCESSOR)       |
| GP GLYCOL PUMP                       | TS TEMPERATURE SWITCH                |
| H HEATER CONTACTOR                   | BC BATTERY CHARGER                   |
| HPS HIGH PRESS SWITCH                | BAT 12VDC BATTERY                    |
| BR BRIDGE RECTIFIER                  | DLT DISCHARGE LINE TEMP SWITCH       |
| PS POWER SUPPLY 5A (12VDC)           | CAP CAPACITOR FOR 24 VDC OUTPUT      |

### OPTIONS

- OPTION 1 - DATA LOGGING PC COMMUNICATION
- OPTION 2 - ELECTRIC HEATER, PROBE, FLOAT & TEMP SW
- OPTION 3 - PRESSURE TRANSDUCER
- OPTION 4 - ALARM HORN
- OPTION 5 - 12VDC BATTERY AND CHARGER
- OPTION 6 - EXTERNAL DATA LOGGER
- OPTION 7 - SATELLITE TRANSDUCER (NOT SHOWN)
- OPTION 8 - COMPRESSOR TEMP PROBE SAFETY
- OPTION 9 - ELECTRIC HEATER 12KW, PROBE FLOAT SW & TEMP SW
- OPTION 10 - VOLTAGE REGULATOR WITH 12VDC FOR GSM POWER
- OPTION 11 - 24 VDC POWER FOR SAWY OR IMT - CANNOT BE USED IF BATTERY CHARGER OR VOLTAGE REGULATOR IS USED
- OPTION 12 - 12VDC PS FOR SAWY OR IMT

**KLINGE**  
4075 East Market Street, YORK PA 17402 USA

For technical assistance:  
Web portal <https://kingecorp.com/request-service>  
Email [technical@kingecorp.com](mailto:technical@kingecorp.com)  
Telephone +1-717-840-4500  
For spare parts please email [spares@kingecorp.com](mailto:spares@kingecorp.com)

**MODEL TCR-109**  
ELECTRICAL SCHEMATIC  
WITH OPTIONS

REV G K35-059B9-41

## 6.7 Thermostat Operation

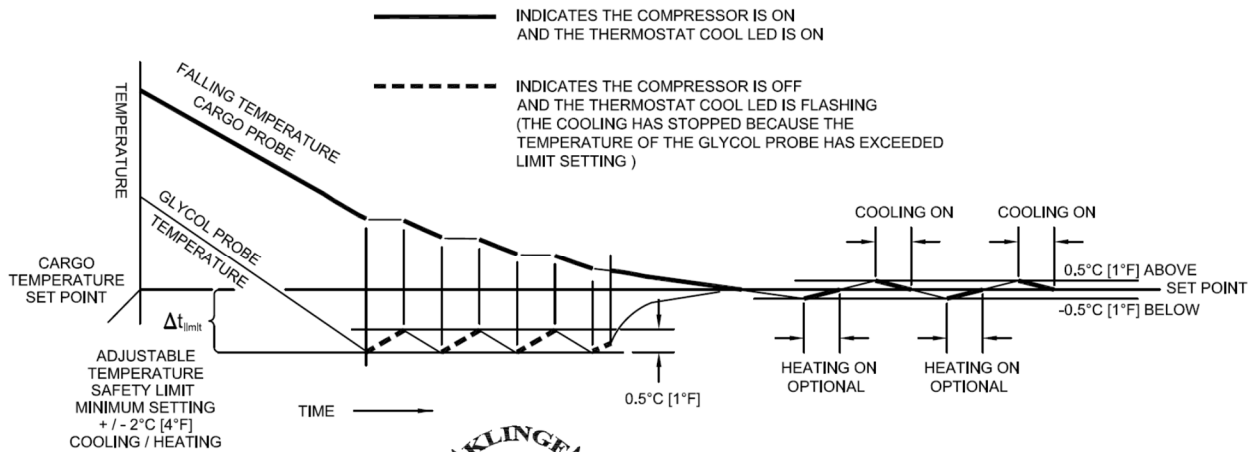

CHART IS SHOWN COOLING  
HEATING IS OPPOSITE  
THE CHART SHOWS THE RELATIONSHIP  
BETWEEN SET POINT, LIMIT AND  
WHICH PROBE (CARGO OR GLYCOL)  
IS CONTROLLING THE UNIT  
COOLING OR HEATING



**NOTE**  
IF THE CARGO PROBE FAILS  
THE GLYCOL PROBE WILL  
CONTROL THE UNIT

### GLYCOL SAFETY LIMIT SETTING

1- THIS IS AN ADJUSTABLE TEMPERATURE LIMIT TO PREVENT THE GLYCOL FROM SUB-COOLING THE CARGO. IT SENSES THE DIFFERENCE FROM THE SET POINT TO THE TEMPERATURE SENSED BY THE GLYCOL PROBE.

2 - WHEN THE TEMPERATURE DIFFERENCE IS GREATER THAN THE SAFETY LIMIT THE COOLING OR HEAT WILL SHUT DOWN AND THE THERMOSTAT COOLING OR HEAT LED WILL FLASH.

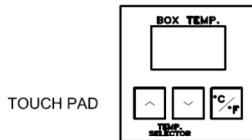

TOUCH PAD



### TOUCH PAD and TEST SWITCH

- 1 - Touch pad shows actual cargo temperature.
- 2 - Push  $\wedge$  or  $\vee$  keys on touch pad to see cargo temperature set point.
- 3 - To see glycol temperature hold the TEST switch down.
- 4 - To see the  $\Delta t$  limit hold the TEST switch down & press  $\wedge$  or  $\vee$  (minimum setting  $\pm 2^\circ\text{C}$  [ $4^\circ\text{F}$ ])
- 5 - To reset  $\Delta t$  hold the TEST switch down and press  $\wedge$  or  $\vee$  keys then to set the limit simultaneously hold  $\wedge$  and  $\vee$  for 2 seconds.

THERMOSTAT FRONT LED			THERMOSTAT DESCRIPTION WHEN LED IS ON
#	LABEL	LED	
1	ON	ON	12 VOLT POWER TO THE THERMOSTAT
2	ALARM ON	ON	AN ALARM IS PRESENT SEE TOUCH PAD FOR ALARM CODE. REFER TO MANUAL FOR ALARM DESCRIPTION
3	PRIMARY	ON	USED FOR DUAL SYSTEMS ONLY ALWAYS ON WITH A SINGLE UNIT
4	NOT USED	N/A	USED ONLY FOR FUNCTION TEST
5	COMP FAIL	ON	COMPRESSOR HIGH PRESSURE SWITCH OPEN OR DISCHARGE LINE TEMP SWITCH OPEN
6	TEMP FAIL	ON	1- PULL DOWN RATE IS LESS THAN $0.06^\circ\text{C}$ [ $0.1^\circ\text{F}$ ] / HOUR 2- EXTERNAL TEMPERATURE FAULT SEE DATA LOGGER (WHEN USED)
7	GLYCOL	ON	GLYCOL PROBE IS CONTROLLING
		FLASHING	GLYCOL PROBE BAD (CONTROLLING ON CARGO PROBE)
8	COOL	ON	THERMOSTAT IS CALLING FOR COOLING
		FLASHING	COMPRESSOR OFF (GLYCOL TEMPERATURE PROBE IS COLDER THAN THE SAFETY LIMIT SETTING)
9	HEAT (OPTIONAL)	ON	THERMOSTAT IS CALLING FOR HEAT
		FLASHING	HEAT OFF (GLYCOL TEMPERATURE PROBE IS WARMER THAN THE LIMIT SETTING)
10	NOT USED	N/A	USED ONLY FOR FUNCTION TEST

For example:

If the Cargo set point is +3°C and the Glycol Limit is set to 7, the system will allow the glycol in the system to go as low as -4°C.

The unit will operate in the following manner:

- The Refrigeration Unit would cool the Glycol Temperature down to the -4°C limit point at which time it would stop cooling and just circulate the glycol.
- If the Cargo is not at the set point temperature, the unit will start cooling again when the Glycol Temperature rises 1°C above the limit. In this case when the Glycol Temp reaches -3°C it will start cooling again until it reaches -4°C Glycol or 3°C Cargo Temp.
- If the Cargo Temperature reaches the set point, the unit will not start cooling again until either the Cargo or Glycol Temperature rise ½°C degree above the set point. In this case that would be 3.5°C.

# KLINGE CORPORATION

Address: 4075 East Market Street York, PA 17402-5100 USA

Telephone: 717.840.4500 Telefax: 717.840.4501

Corporate website - [www.klingecorp.com](http://www.klingecorp.com)



## SECTION SEVEN - SERVICE PARTS

- 7-1A Unit refrigeration outside view
- 7-1B Unit refrigeration with optional heater kit
- 7-2 Unit refrigeration with covers removed
- 7-3 Unit pump assembly
- 7-4 Blower and motor assembly
- 7-5 Refrigeration unit parts and piping schematic
- 7-6A Small electrical control box, dual probes
- 7-6B Small electrical control box, cable hook-up, heater, float switch & dual probes
- 7-7 Expansion Tank

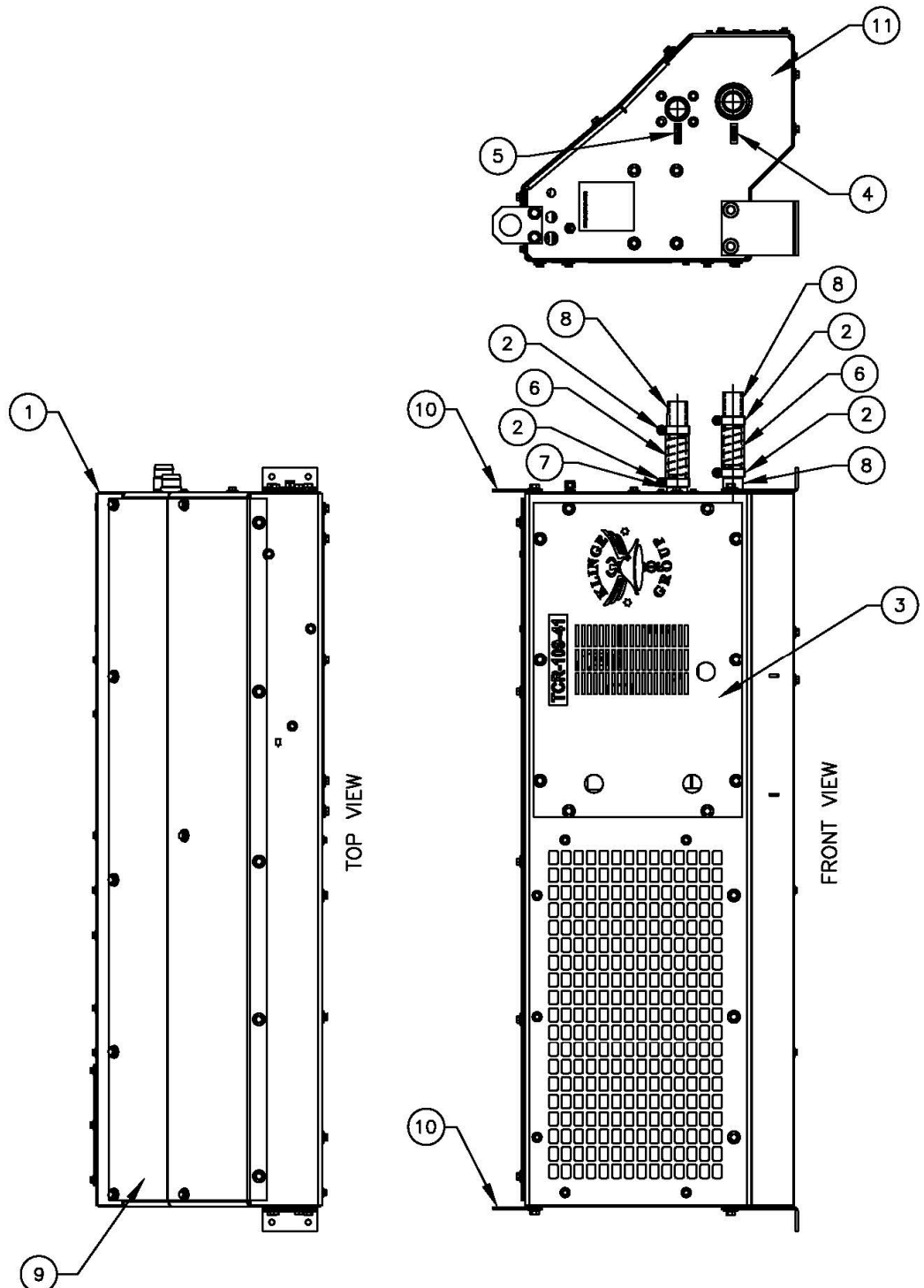

SECTION 7.1A  
UNIT REFRIGERATION OUTSIDE VIEW

**SECTION 7.1A****UNIT REFRIGERATION OUTSIDE VIEW**

<b>ITEM</b>	<b>PART NO.</b>	<b>DESCRIPTION</b>	<b>QTY.</b>
1	460-12850-41	UNIT GLYCOL (TCR-109-41)	1
2	K21- 16379-05	CLAMP CONSTANT TORQU SS 1-1/16	4
3	360-12896-41	PANEL FRONT ASSY (TCR 109-41)	1
4	K35-05896-00	LABEL GLYCOL IN	1
5	K35-05897-00	LABEL GLYCOL OUT	1
6	060-12592-05	TUBE PVC CLEAR W/WIRE 1.5"Dx9"	2
7	060-12812-01	CONNECTION PUMP INLET 3" LONG	1
8	060-12812-02	CONNECTION PUMP INLET 11" LONG	3
9	060-12877-40	COVER TOP WHITE (TCR 109-40)	1
10	060-13153-00	BRACKET LIFTING	2
11	360-12851-41	FRAME NUT W/INSERTS (TCR 109-41)	1



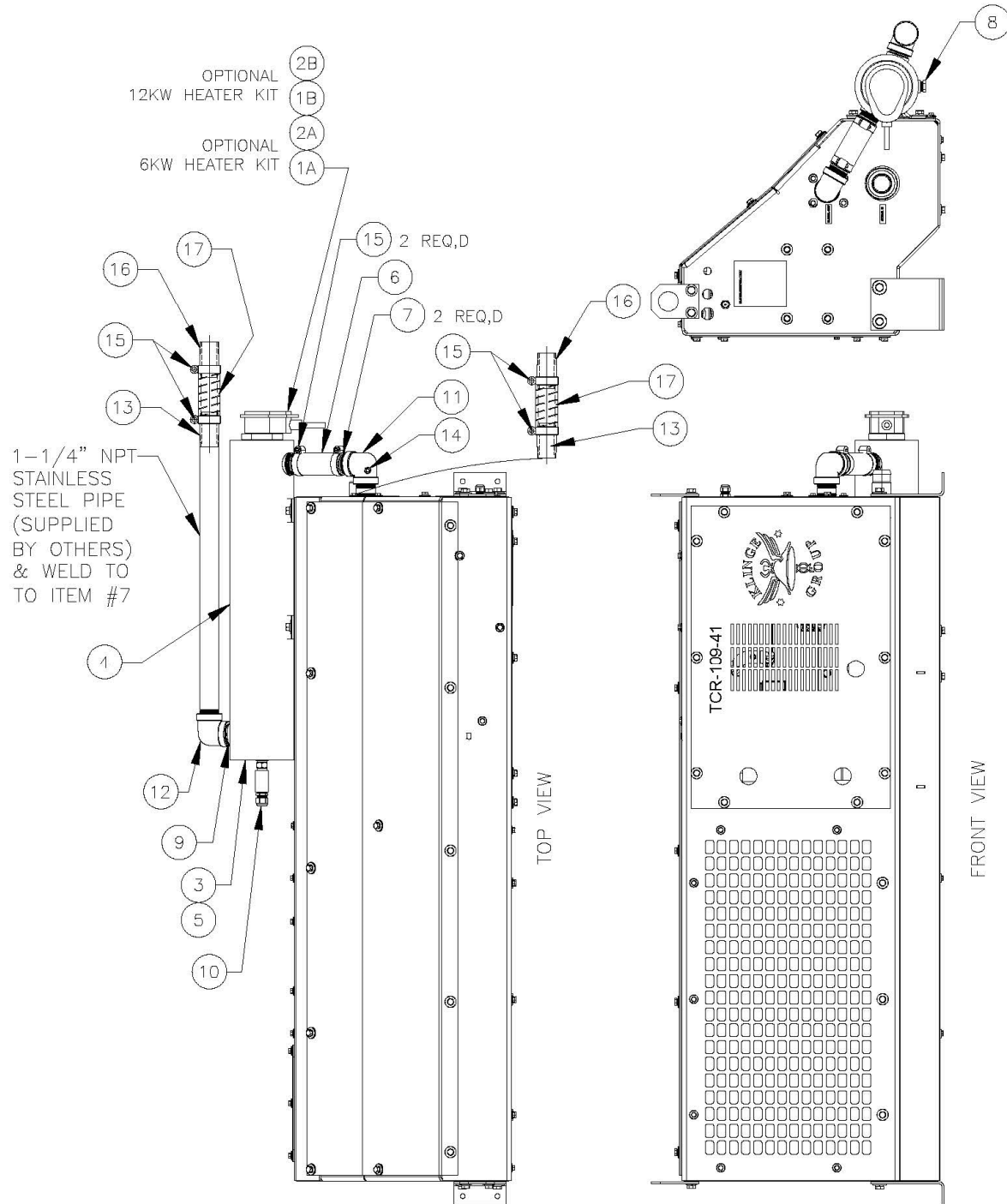

SECTION 7.1B  
UNIT REFRIGERATION WITH OPTIONAL HEATER KIT

**SECTION 7.1B****UNIT REFRIGERATION WITH OPTIONAL HEATER KIT**

<b>ITEM</b>	<b>PART NO.</b>	<b>DESCRIPTION</b>	<b>QTY.</b>
1A	460-13400-08	HEATER REAR MTG 6 KW (INCLUDES ITEMS 2A & 3-16)	1
1B	460-13400-14	HEATER REAR MTG 12 KW (INCLUDES ITEMS 2B & 3-16)	1
2A	K25-26356-06	HEATER IMMERSION 6KW 3PH 2" MPT	1
2B	K25-26356-12	HEATER IMMERSION 12KW 3PH 2" MPT	1
3	360-13401-12	TANK HEATER REAR MOUNTING WELDMENT	1
4	060-13490-12	INSULATION HEATER REAR MOUNTED	1
5	060-13597-12	INSULATION HEATER BOTTOM	1
6	060-12592-07	TUBE PVC CLEAR W/WIRE 1.5"ID 4-5/8" LG	1
7	060-12812-00	CONNECTION PUMP INLET 2.25"LG SS 1-1/4" LG	2
8	K23-13069-04	PLUG PIPE HEX BRS 1/2" MPT	1
9	K23-13228-07	NIPPLE SS 1-1/4" SCH 40 1-5/8 LG	1
10	360-17717-20	CABLE TEMP SWITCH GLYCOL NC OPEN 98C CLOSE 85C	1
11	060-18636-00	ELBOW WITH VALVE HOLE	1
12	K23-13255-07	ELBOW SS 90 DEG 1-1/4FPT 150#	1
13	K23-13228-72	NIPPLE SS 1-1/4" SCH40 2/1/2" LG	2
14	K22-06907-00	VALVE BRASS SCHRADER STRAIGHT 1/8 MPT	1
15	K21-16379-05	CLAMP HOSE CONSTANT TORQUE SS 1-1/16" – 2" ID	6
16	060-12812-02	CONNECTION PUMP INLET 1-1/4" MPT	2
17	060-12592-05	TUBE PVC CLEAR W/WIRE 1.5"ID 9" LG	2

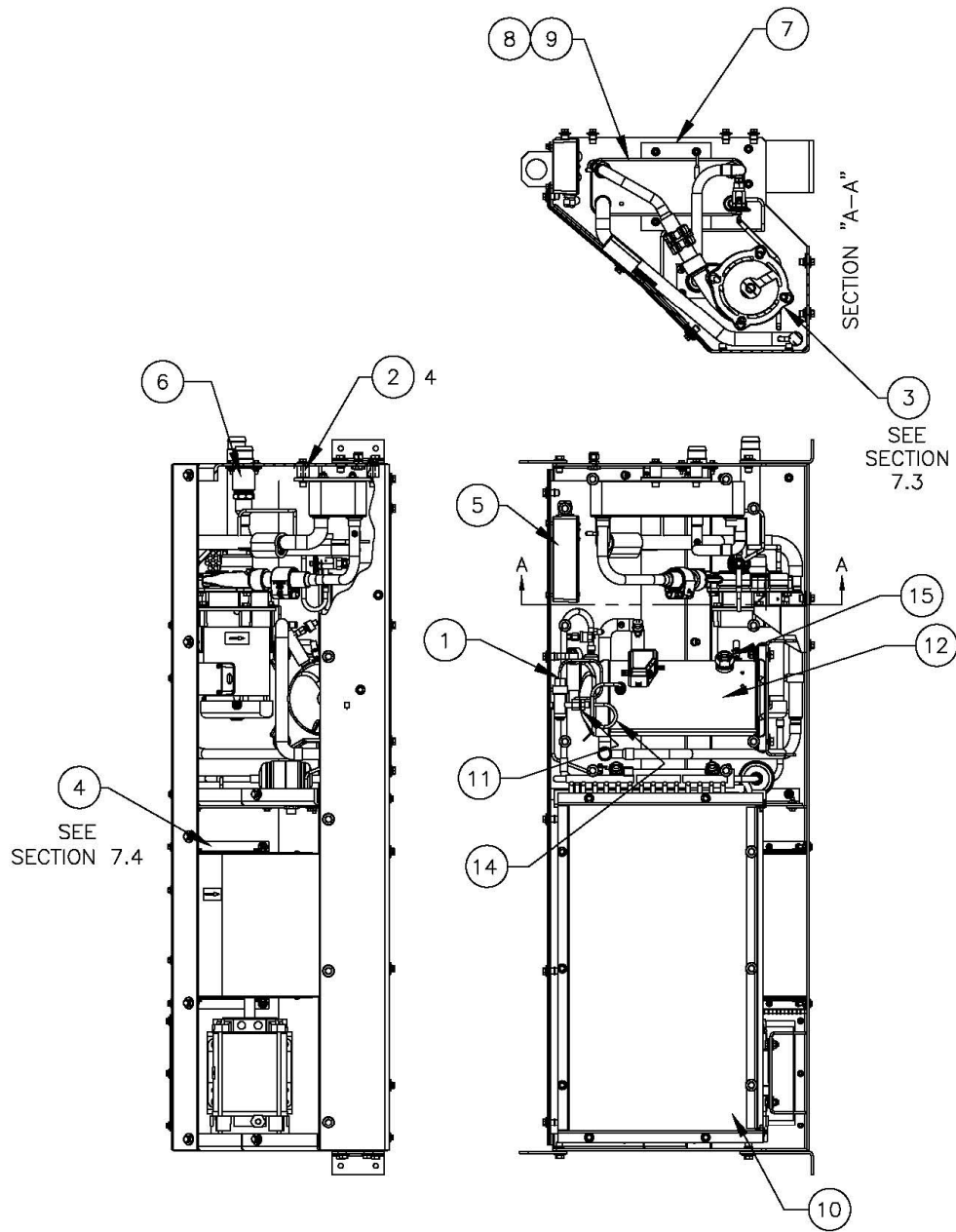

**SECTION 7.2  
UNIT REFRIGERATION  
W / COVERS REMOVED**

**SECTION 7.2****UNIT REFRIGERATION WITH COVERS REMOVED**

<b>ITEM</b>	<b>PART NO.</b>	<b>DESCRIPTION</b>	<b>QTY.</b>
1	K15-00042-04	KIT VALVE DTC DISCH TEMP CONTL	1
2	060-13189-00	SPACER CHILLER MTG	4
3	360-12934-41	PUMP MTG ASSEMBLY (TCR 109-41)	1
4	360-12897-41	BLOWER ASSY (TCR 109-41)	1
5	360-12944-41	ASSY JUNCTION BOX (TCR 109-41)	1
6	360-13154-00	ASSEMBLY PLATE GLYCOL OUTLET	1
7	360 -13188-04	PLATE CHILLER MTG	1
8	K26-25311-00	CHILLER HEAT EXCHANGER	1
9	060-12542-02	INSUL CHILLER 3 TON	1
10	360-13214-41	COIL COND ASSY W/ INSERTS	1
11	K15-00042-07	O-RING DTC VALVE INCLUDED WITH ITEM 1	1
12	360-12879-40	COMPR SCROLL MARINIZE PIT GUARD W/CABLE 9000 BTU/HR (INCLUDES ITEM 15)	1
13	060-13229-01	STRIP SPONGE 1/8 X 1 X 170.4"L	1
14	360-13502-00	TUBE CU 1/4" HOT VALVE TO COMP WITH ADPT	1
15	K15-00042-17	SIGHT GLASS OIL	1

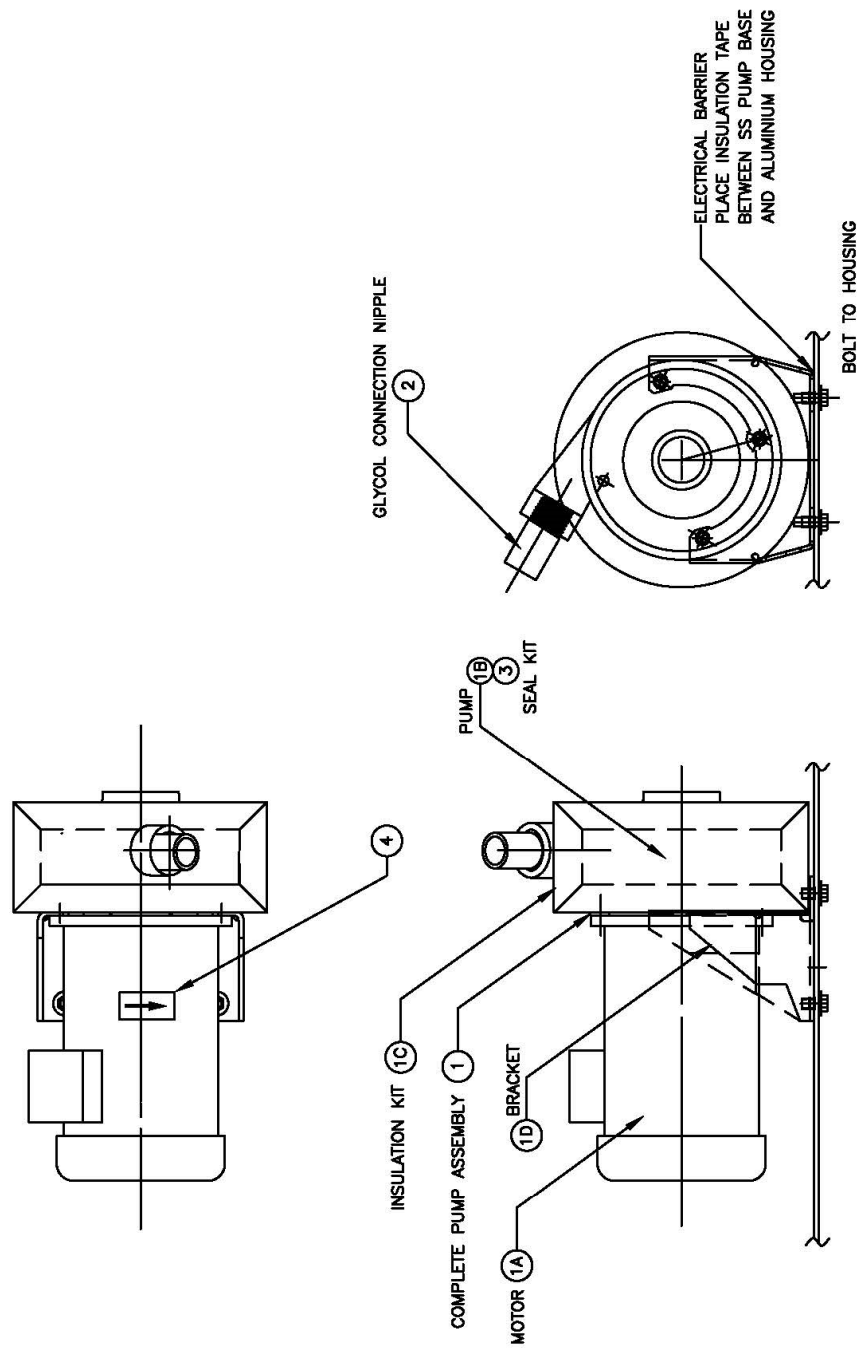

**SECTION 7.3  
UNIT PUMP ASSEMBLY**

**SECTION 7.3****UNIT PUMP ASSEMBLY**

<b>ITEM</b>	<b>PART NO.</b>	<b>DESCRIPTION</b>	<b>QTY.</b>
1	360-12934-41	MARINIZED MOTOR - PUMP - MOUNTING BRACKET , INSULATION AS COMPLETE "DROP IN" REPLACEMENT PART	1
1A	360-13213-00	MARINIZED ELECTRICAL MOTOR (ONLY)	1
1B	360-13212-00	MARINIZED PUMP (ONLY)	1
1C	060-12543-00	INSULATION KIT	1
1D	060-12895-01	PUMP BRACKET	1
2	060-18297-01	CONNECTION GLYCOL 1" MPT	1
3	K26-25035-00	REPLACEMENT SEAL KIT	1
4	K35-05606-00	LABEL ARROW	1

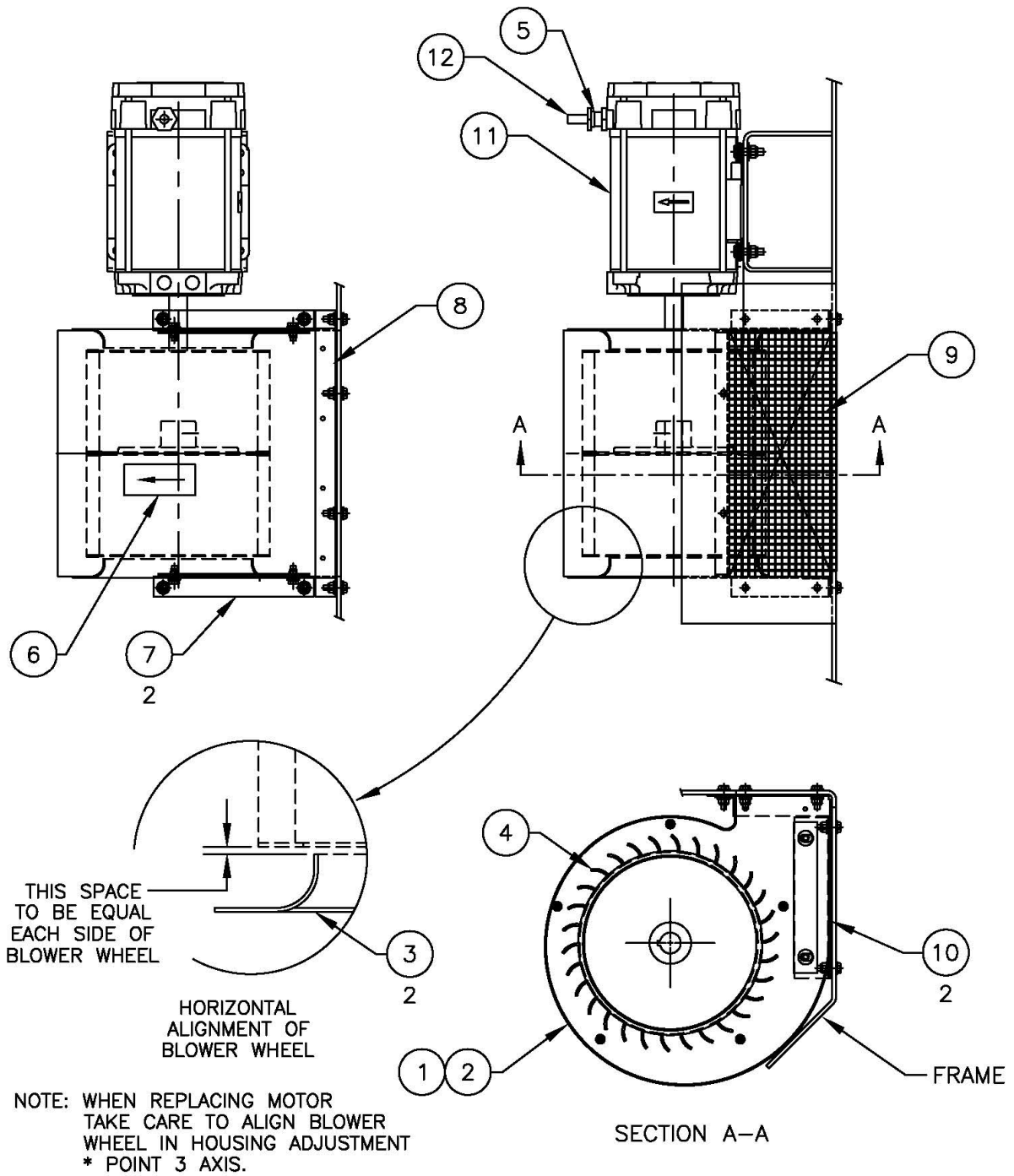

**SECTION 7.4  
 BLOWER & MOTOR ASSEMBLY**

**SECTION 7.4****PANEL BLOWER ASSEMBLY**

<b>ITEM</b>	<b>PART NO.</b>	<b>DESCRIPTION</b>	<b>QTY.</b>
1	360-12897-41	PANEL BLOWER ASSY TCR-109-41	1
2	K26-25059-40	HOUSING BLOWER AL .06 THICK 750-	1
3	K26-25060-00	RING INLET CONE AL 9.19D WHEEL	2
4	K26-25061-00	WHEEL BLOWER DOUBLE INLET AL 9.1	1
5	K25-26570-20	GLAND EX CABLE ATEX M20 (0.43 – 0.56)	1
6	K35-05606-00	LABEL ARROW 1"X 2"	1
7	060-12864-00	SUPPORT BLOWER TCR 109 WHITE	2
8	360-16026-41	DUCT COND DISCHARGE AIR	1
9	060-12878-01	SCREEN DISCHARGE AIR	1
10	060-12942-01	PLATE NUT LOWER TCR-109	2
11	360-18054-01	MOTOR CONDENSER BLOWER MODIFIED	1
12	360-18055-01	CABLE CONDENSER FAN TO JUNCTION BOX	1



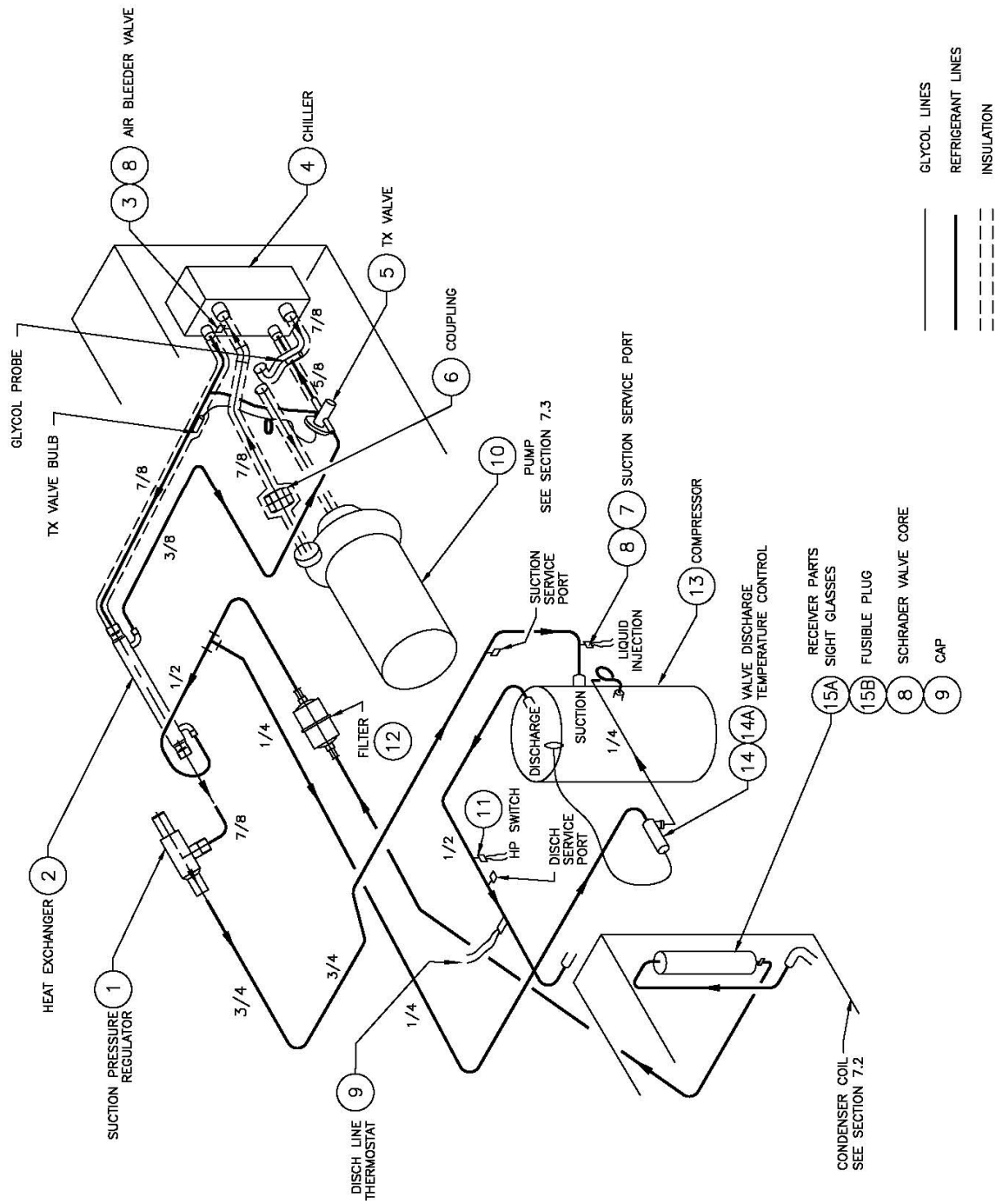

**SECTION 7.5**  
**TCR 109-41**  
**REFRIGERATION UNIT PARTS**  
**& PIPING SCHEMATIC**

**SECTION 7.5****REFRIGERATION UNIT PARTS & PIPING  
SCHEMATIC**

<b>ITEM</b>	<b>PART NO.</b>	<b>DESCRIPTION</b>	<b>QTY.</b>
1	K22-07026-00	VALVE SUCTION PRESS REGULATOR	1
2	K26-17451-03	HEAT EXCHANGER 7/8 C X 3/8 C	1
3	K22-06959-00	VALVE TANK 1/8 MPT TIRE STEM	1
4	K26-25014-02	CHILLER 3 TON BOLTS ON BACK	1
5	K25-26949-01	VALVE TX 7/8C X 1/2C 1/4 EQUAL	1
6	K23-13408-00	COUPLING PIPE AXIALLY RESTRAINED	1
7	360-18155-01	SWITCH LOW PRESS ASSEMBLY NC 5-20 PSI	1
8	K22-02475-00	CORE VALVE CHARGE PORT (INCLUDED IN ITEM 3)	1
9	360-13234-41	CABLE THERMOSTAT KIT COMPRESSOR DISCHARGE	
10	360-12934-41	PUMP ASSEMBLY	1
11	360-13232-41	CONTROL PRESS NC OPENS 450 PSI CLOSE	1
12	K26-10795-01	FILTER DRIER 1/2C	1
13	360-12879-40	COMPRESSOR SCROLL TCR-109 MARINIZED	1
14	K15-00042-04	KIT VALVE DTC DISCHARGE TEMPERATURE CONTROL	1
14A	K15-00042-07	O-RING DTC VALVE	
15A	K26-25031-00	SIGHT GLASS 1/2" MPT (INCLUDED IN ITEM 10 OF SECTION 7.2)	1
15B	K23-13042-00	PLUG FUSIBLE 1/8" MPT (INCLUDED IN ITEM 10 OF SECTION 7.2)	1

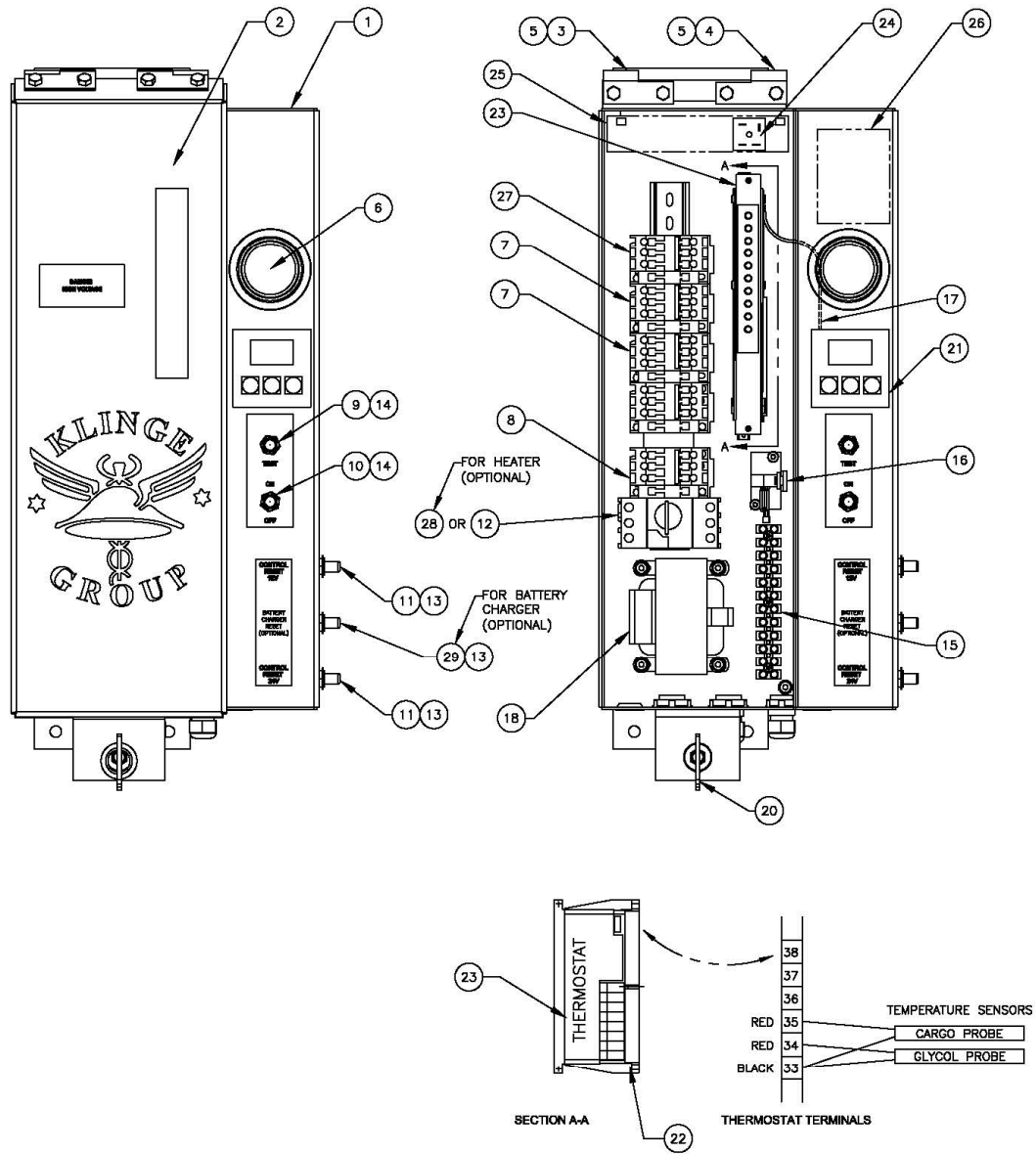

**SECTION 7.6A  
SMALL ELECTRICAL CONTROL BOX  
DUAL PROBES WITH OPTIONS**

**SECTION 7.6A**

**SMALL ELECTRICAL CONTROL BOX  
DUAL PROBES**

ITEM	PART NO.	DESCRIPTION	QTY.
1	460-17640-01	ELECT BOX ASSEMBLY (TCR 109 SMALL STYLE)	1
2	360-17641-41	DOOR ELECTRICAL BOX TCR-109 SMALL	1
3	K29-17879-01	HINGE SLIP SS 9/32 HOLES SOCK RIGHT HAND	1
4	K29-17880-01	HINGE SLIP SS 9/32 HOLES SOCK LEFT HAND	1
5	060-09113-00	INSULATOR HINGE	2
6	360-17648-00	LAMP ALARM ASSY TCR/TRS SMALL	1
7	K24-22155-00	CONTACTOR 9A 3P 24V 60/50 HZ COIL	3
8	K24-22321-00	CONTACTOR REVERSING 12A 3P 24V 50/60	1
9	K24-22152-00	SWITCH TOGGLE SPDT MOM *ON-OFF-*ON	1
10	K24-22144-00	SWITCH TOGGLE 3PST ON-OFF #6 SCR	1
11	K24-22330-00	CIRCUIT BREAKER 4 AMP 1 POLE 1/4PO PANEL MT	2
12	K24-22363-13	CIRCUIT BREAKER IEC 3POLE 9-13 AMP	1
13	K24-18164-00	BOOT CIRCUIT BREAKER 3/8-27 THREAD ACCORD	2
14	K24-17239-00	BOOT TOGGLE SW	2
15	K25-26488-12	BLOCK TERMINAL STRIP 12P 45A 8-18 GA	1
16	360-16398-00	CURRENT SENSING TRANSFORMER 20A 3PH VERTICAL	1
17	360-12540-05	CABLE RIBBON SHLD 13` 10 WIRES 13LG	1
18	K25-26624-10	TRANSFORMER 230 V 400V 24V/12V	1
19			
20	K21-16313-00	FASTENER BABY ANTILUSE M8x1.25	1
21	K31-00811-00	DISPLAY TEMP W/SELECTOR F/C M	1
22	360-10829-00	BASE THERMOSTAT	1
23	K31-00858-40	THERMOSTAT W/ LABELS TCR 109 SMALL	1
24	360-17646-00	RECTIFIER BRIDGE 1PH 25A 200V MTG TAPE 1"	1
25	360-13396-30	BATTERY 12V 2.3 AH MTG TAPE 6" .18	1
26	360-15580-01	BATTERY CHARGER MODIFIED 24 VAC 12 VDC 3 AMP	1
27	K24-22156-00	CONTACTOR 16A 3P 24 VAC 50/60 Hz	1
28	K24-22363-25	CIRCUIT BREAKER IEC 3P 19 – 25 AMP	1
29	K24-22363-26	CIRCUIT BREAKER 3 AMP 1 POLE 1/4 PO PANEL MTG	1

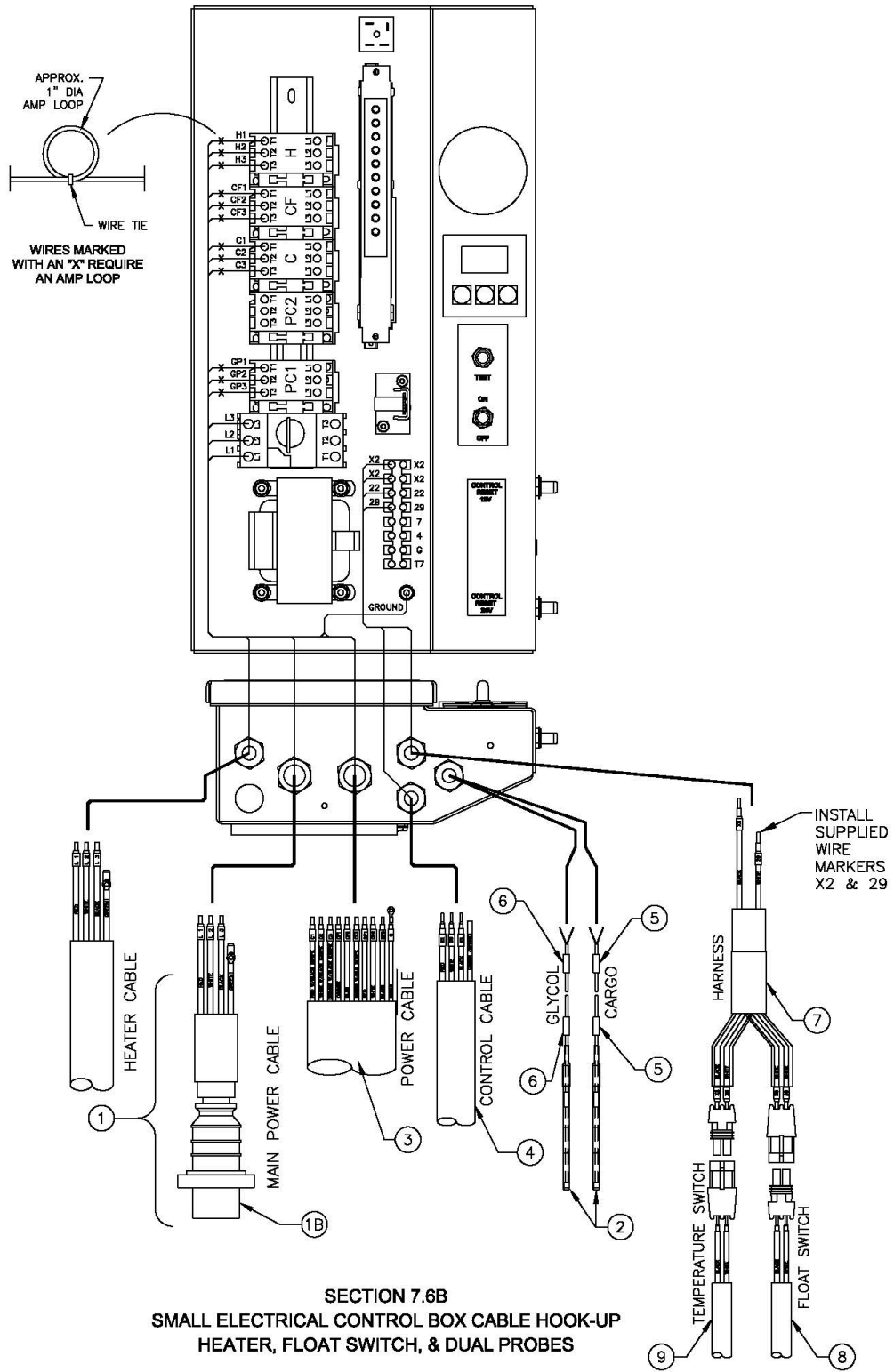

**SECTION 7.6B**  
**SMALL ELECTRICAL CONTROL BOX CABLE HOOK-UP**  
**HEATER, FLOAT SWITCH, & DUAL PROBES**

**SECTION 7.6B****SMALL ELECTRICAL CONTROL BOX CABLE  
HOOK-UP  
HEATER, FLOAT SWITCH & DUAL PROBES**

<b>ITEM</b>	<b>PART NO.</b>	<b>DESCRIPTION</b>	<b>QTY.</b>
1	360-17648-01	CABLE ASSEMBLY MAIN POWER TCR-109 18M	1
1B	K25- 20474-00	PLUG POWER 32A 380/440V 3P+G WATER TIGHT	1
2	360-13807-00	KIT PROBE 6" UNIVERSAL	3
3	360-17648-03	CABLE POWER TO TCR-109 BOX TO UNIT	1
4	360-17648-02	CABLE CONTROL TO TCR-109 BOX TO UNIT	1
5	K25-26120-28	MARKER WIRE .25 ID CARGO	4
6	K25-26120-29	MARKER WIRE .25 ID GLYCOL	4
7	360-18265-00	HARNESS FLOAT SWITCH AND TEMPERATURE SWITCH	1
8	360-13620-02	CONTROL LOW LIQUID LEVEL ( FLOAT SWITCH )	1
9	360-17717-20	CABLE TEMPERATURE SWITCH GLYCOL	1

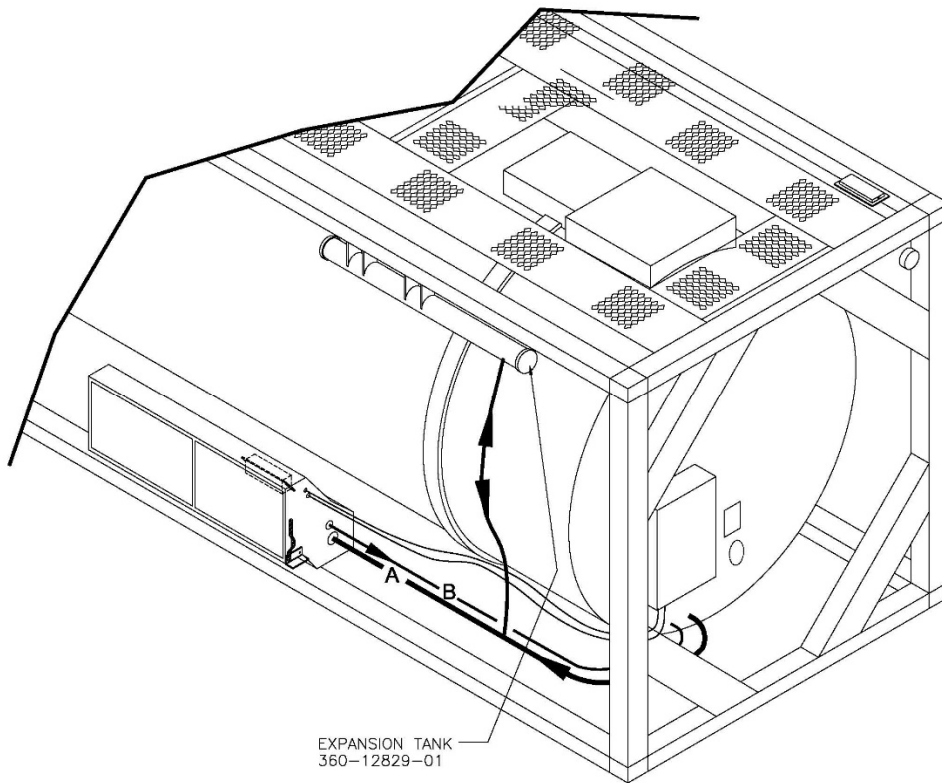
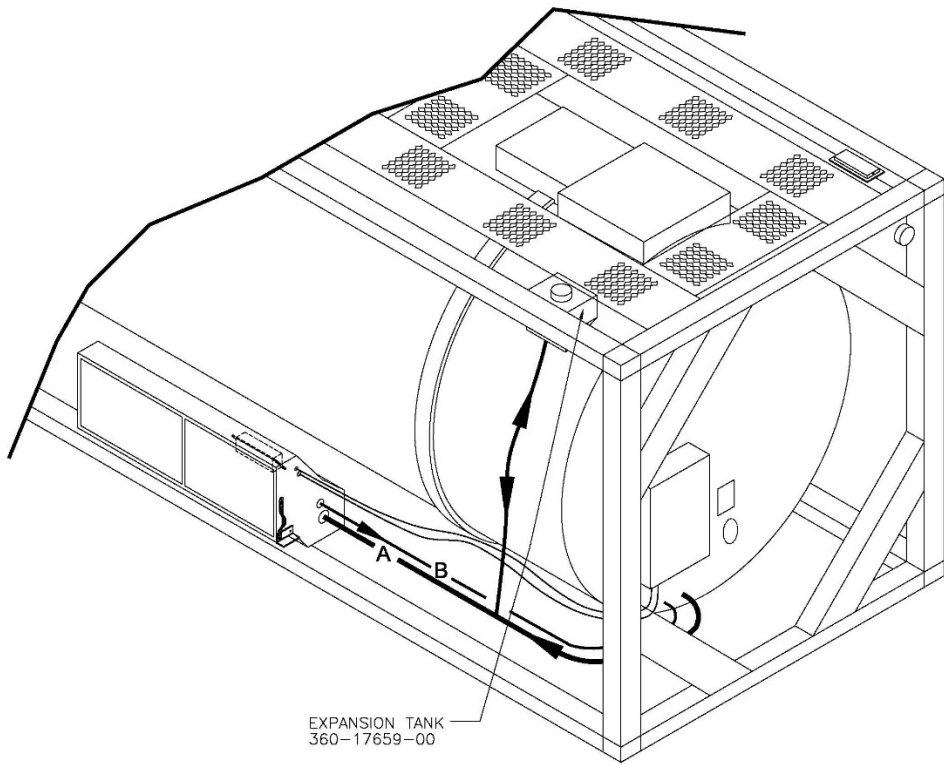

**SECTION 7.7  
EXPANSION TANK**

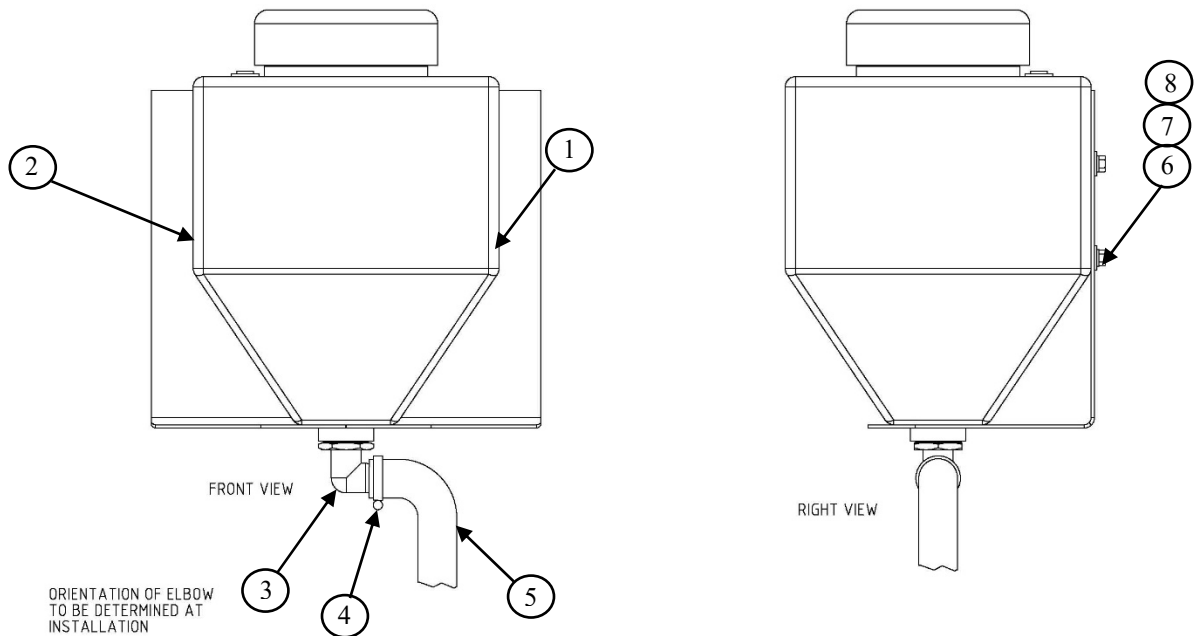

**SECTION 7.7A**

**GLYCOL EXPANSION TANK PLASTIC**

ITEM	PART NO.	DESCRIPTION	QTY.
1	360-17659-00	TANK EXPANSION 4 GALLON PLASTIC (INCLUDES ITEMS 2 THRU 8)	1
2	K26-25222-00	TANK GLYCOL POLYETHYLENE 4 GALLON	1
3	K23-13395-00	ELBOW 90 BLACK POLYPROPYLENE	1
4	K21-16379-03	CLAMP CONSTANT TORQUE 13/16 .812 - 1.5 RANGE	1
5	K28-10897-02	HOSE HEAVY DUTY SPIRAL REINFORCED 1.00 ID	8
6	K21-14072-00	WASHER FLAT 5/16 X .88 OD SS	4
7	K21-14761-00	WASHER LOCK SPG SS 5/16 HEAVY	4
8	K21-14360-00	SCREW HEX SS 5/16-18 X 3/4	4



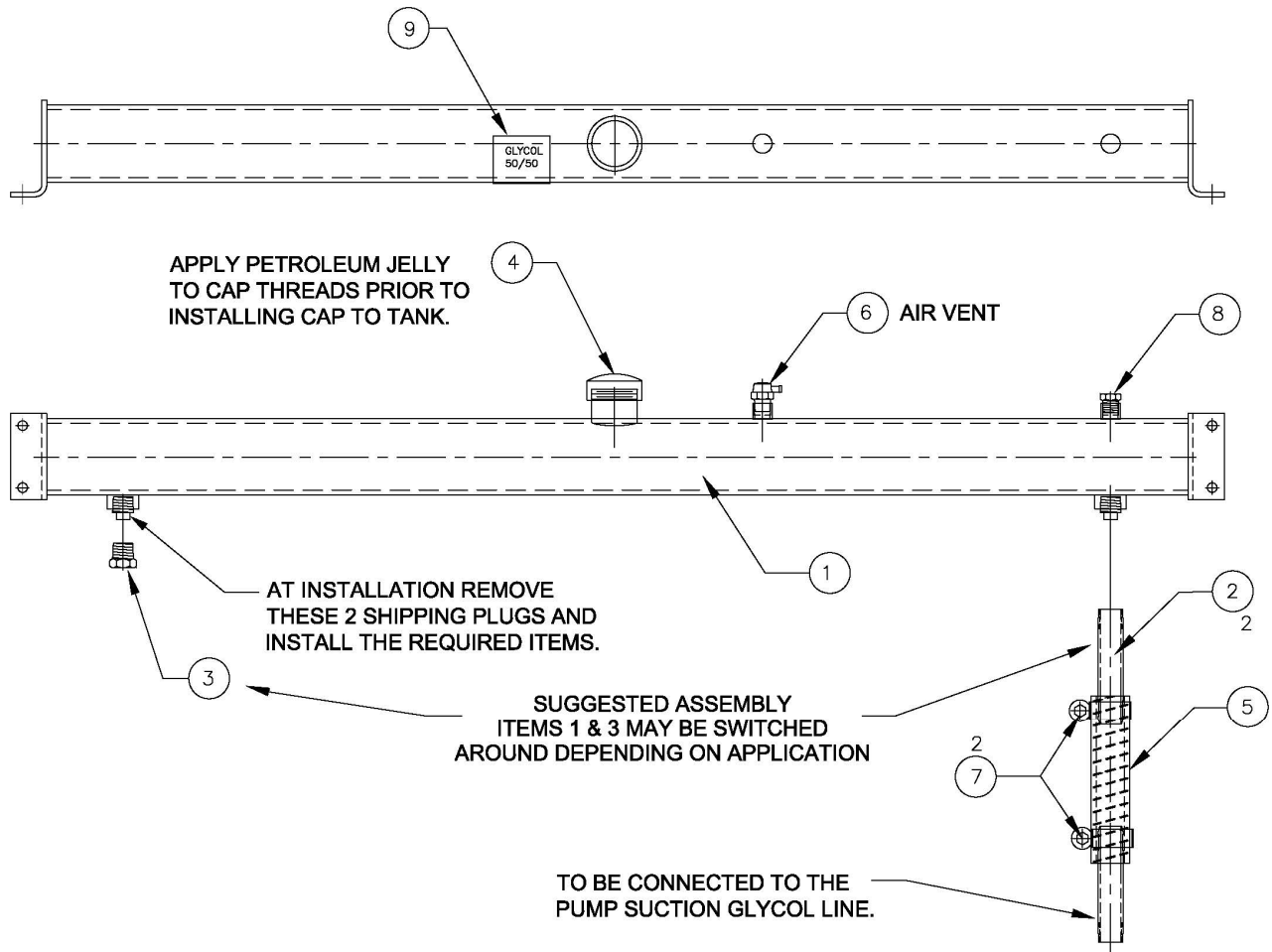

**SECTION 7.7B GLYCOL EXPANSION TANK ALUMINUM**

ITEM	PART NO.	DESCRIPTION	QTY.
1	360-12829-01	TANK EXPANSION 2.5 GALLON ALUMINUM (INCLUDES ITEMS 2 THRU 9)	1
2	060-13197-00	CONNECTION GLYCOL 1" NPT X 6"	2
3	K23-13258-06	PLUG PIPE 1" STAINLESS STEEL	1
4	K26-24792-01	CAP FUEL 2" NPS W/8" CHAIN	1
5	060-13283-01	TUBE PVC SPIRAL REINF	1
6	K26-24768-00	VENT BALL CHECK 1/2 MPT	1
7	K21-16379-05	CLAMP CONST TORQUE	2
8	K23-13069-04	PLUG PIPE HEX BRS 1/2 MPT	1
9	K35-06012-00	LABEL GLYCOL 50/50	1

## **ADDENDUM – DUAL SYSTEMS**

### **A.1 General Description**

As stated in Section 1.0 of this manual, the TCR-109 is designed to be mounted on the bottom side rail of beam and frame tanks, and can be mounted to either side of the tank.

In some cases, two TCR-109 units are mounted to the frame of a tank, one each side, giving 100% machine redundancy as security for the cargo integrity.

Ideally each TCR-109 will have independent piping channels through the tank container. If this is not possible, Klinge Corporation can provide non-return valves to install in the system to prevent glycol from the operating unit to flow back into the non-operating TCR-109 unit.

### **A-2 Dual System Configuration**

One main incoming power cable is necessary to provide power to the system. Klinge provides a power cable to carry power from one electrical control box to the other.

The System 1 and System 2 electrical control boxes communicate via a CAN bus cable.

Each control box of a dual system must be equipped with Klinge thermostat K31-00950-00 in place of Item 23 of Illustration 7.6A of the Service Parts section of this manual.

### **A-3 Dual System Operation**

Each of the two TCR-109 units that make up the Dual TCR-109 system operate like an individual TCR-109. But for the dual system to operate properly, each system must be turned “ON” and set to the same set point temperature.

Start either System 1 or System 2 as per Section “1.9 TCR-109 Standard Operating Procedures” of this manual.

If System 1 is to be primary, start System 2 approximately 15 seconds after starting System 1.

If System 2 is to be primary, wait 3 minutes to start System 1.

Ensure the set point of both systems is equal.

After each TCR-109 unit has performed the function test, the first unit turned on will operate as the primary unit. The other unit will be considered the secondary unit, and after a short period of time will go into “sleep” mode. During “sleep” mode the unit’s display will go dark, but will light up by pressing any button on the touch pad. The secondary system will automatically become active and take over control of the tank container in the event of an alarm to the primary unit.

The system control logic is designed to automatically switch from the operating system to the dormant system after 48 hours of continuous power on. This switching feature will continue from system to system while the system is continuously powered on.

If the system is powered down, the 48 hour timer resets to zero upon restart.

#### A.4 Dual System Alarm Codes

All standard TCR-109 alarm codes are relevant. Two additional alarm codes may appear based on the requirements of communication between the two units.

<b>ALARM CODE</b>	<b>ALARM NAME</b>	<b>ALARM CONDITION</b>	<b>ALARM CLEAR</b>	<b>SUGGESTION FOR REPAIR</b>
A41	Set point different Sys 1/Sys 2	If the systems have set points 1°C or greater difference, the alarm is set.	The alarm is cleared when system set points are made less than 1°C different.	Check both system set points, and make equal.
A42	No response from other unit	If a signal is not received between the 2 systems for a time of 3 minutes the alarm is set.	The alarm is cleared when a signal is received between both systems.	Check connection of CAN Bus cable.

# A.5 Dual System Electrical Schematics

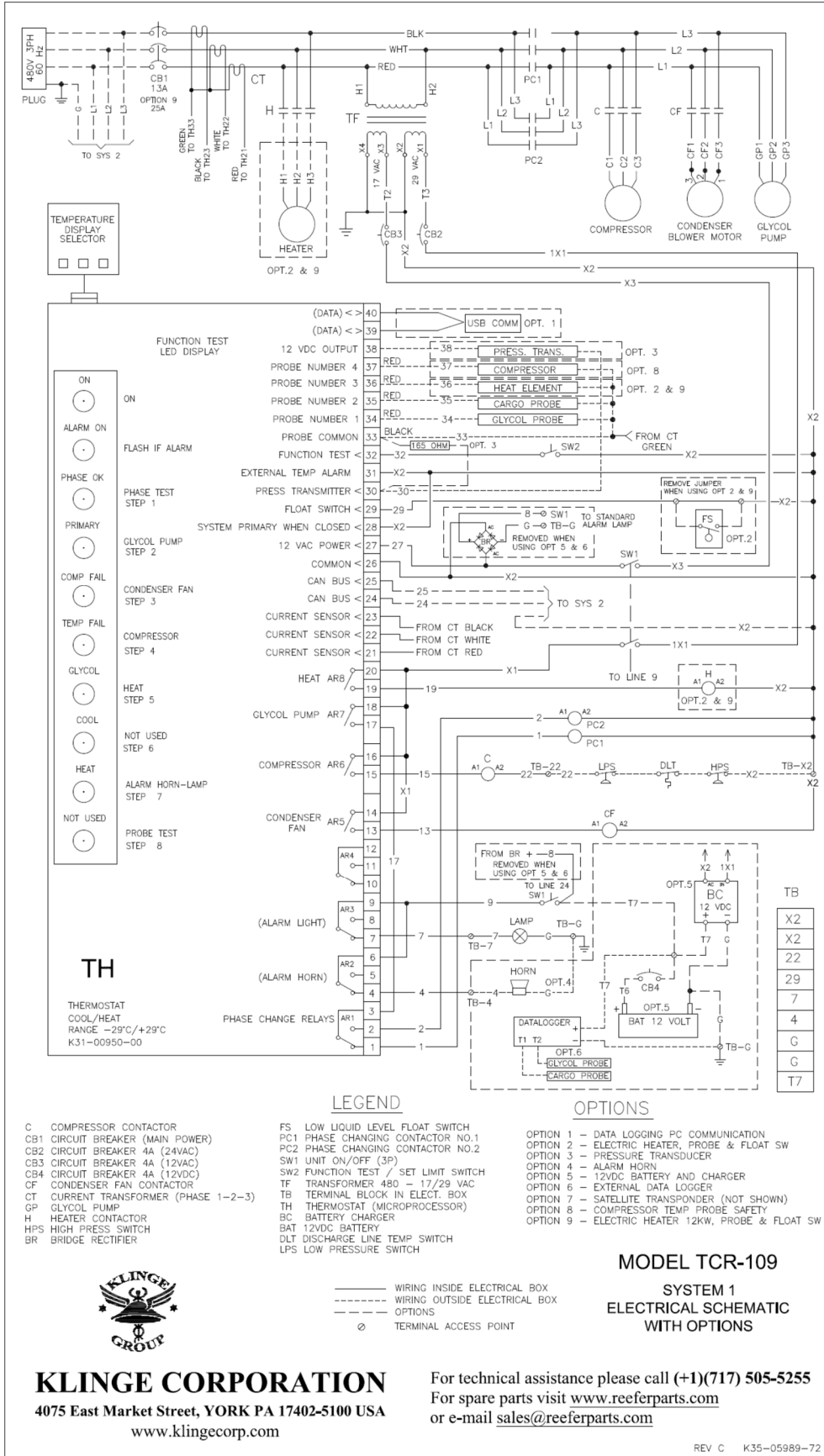

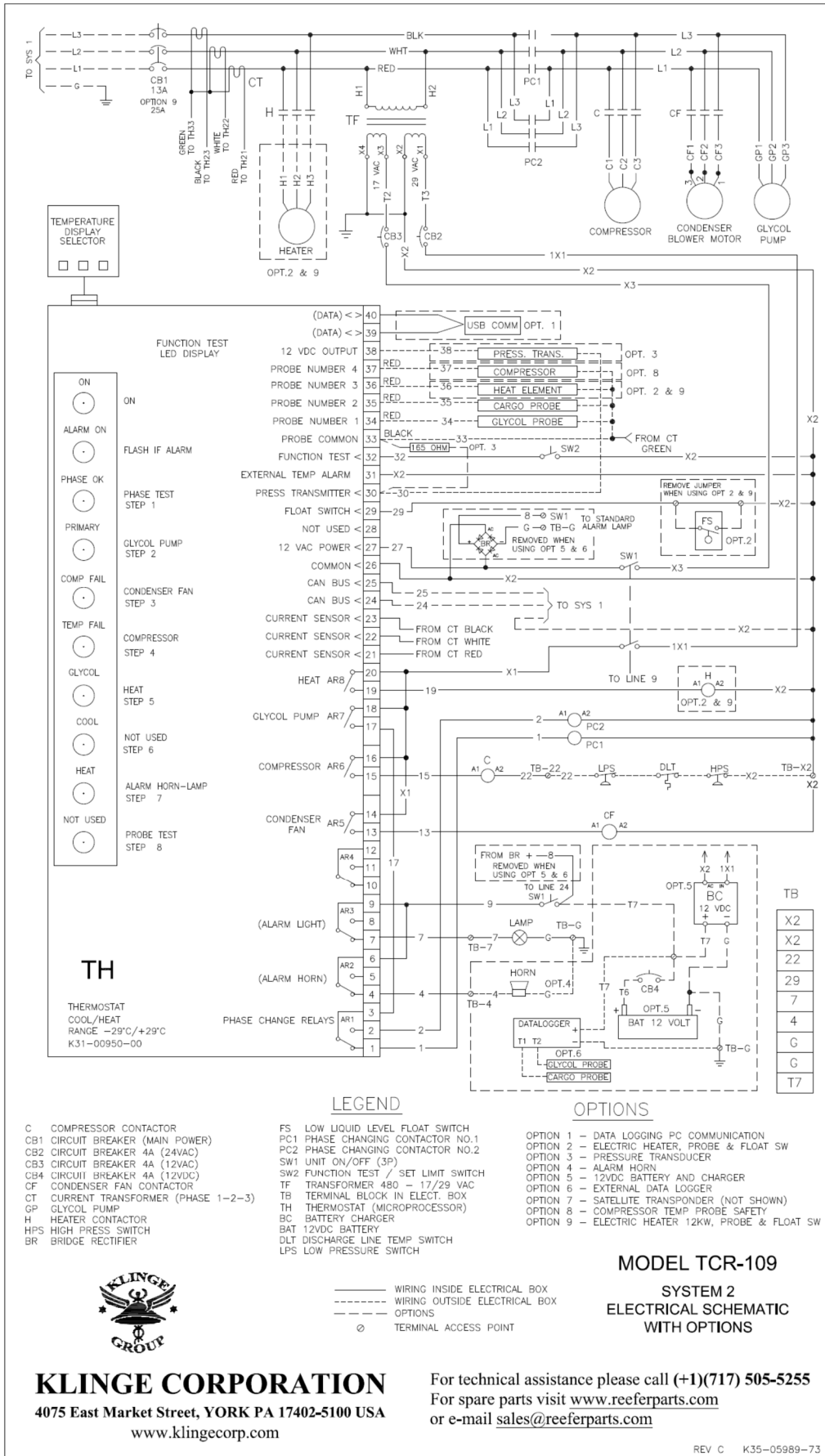

## A.6 Dual System Installation Kit Drawing

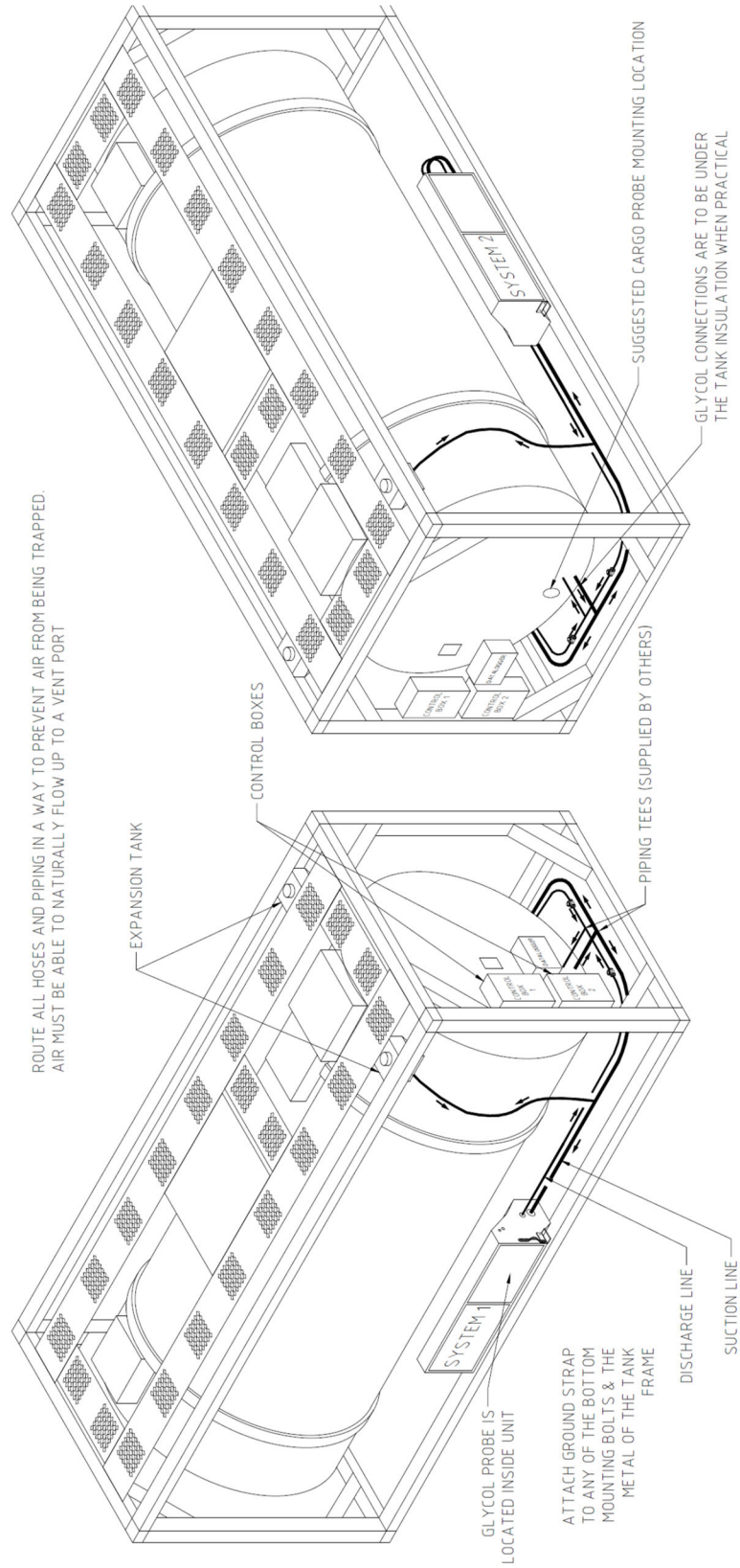

## A.7 Dual System Control Box #1

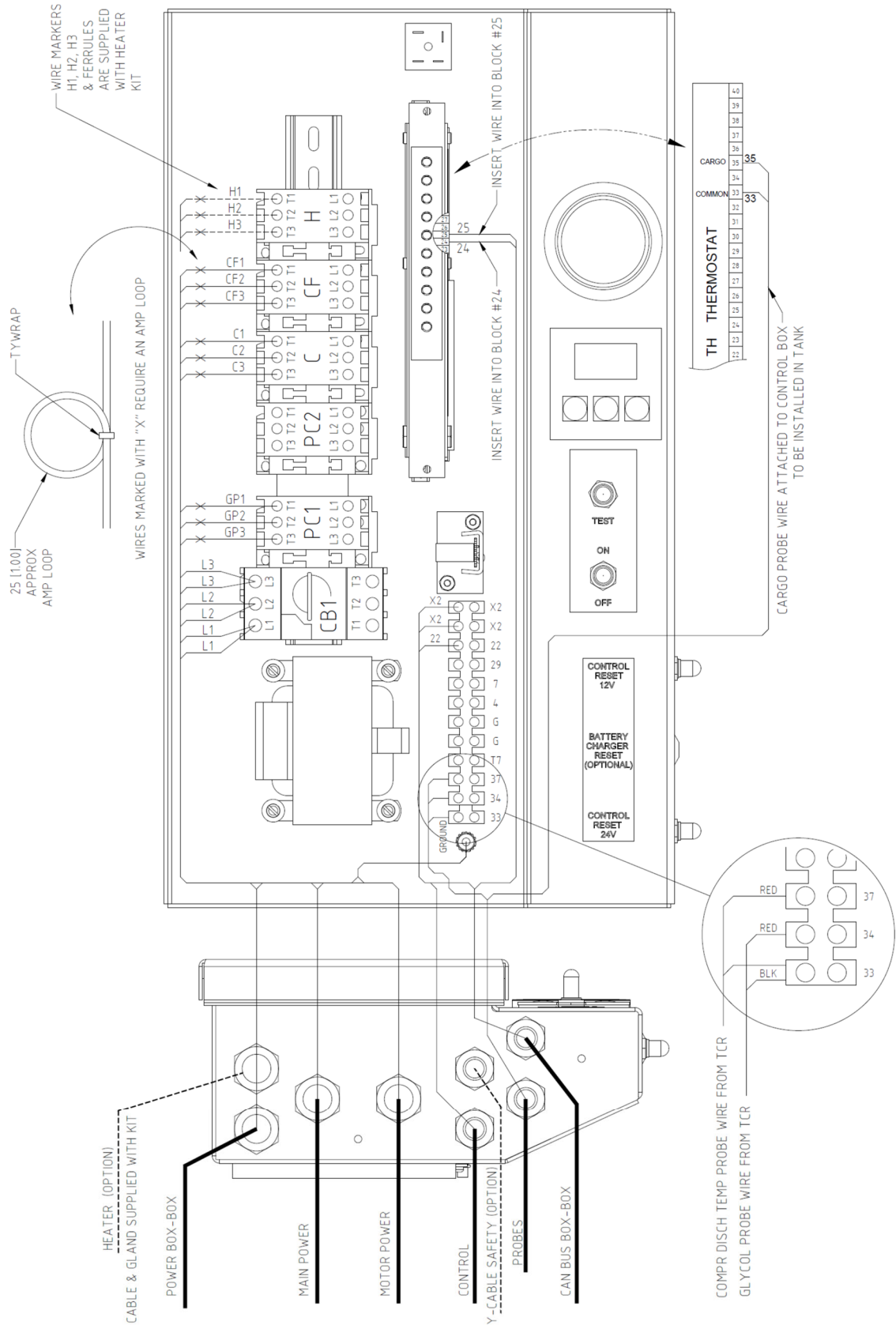

## A.8 Dual System Control Box #2

