



MODEL TCR-104-07: Standard

MODEL TCR-104-08: Remote Electrical Box

MODEL TCR-104-09: With Alarm System &
Version 2 Recorder

MODEL TCR-104-10: Standard W/ Drain – R-404A

MODEL TCR-104-20: Standard W/ Drain – R-452A

CLOSED GLYCOL SYSTEM
(Options)

Heat and Microprocessor Data logging

TANK CONTAINER REFRIGERATION UNIT OPERATION, SERVICE AND PARTS MANUAL

Address: 4075 East Market Street York, PA 17402-5100 USA

Telephone: 717-840-4500 Telefax: 717-840-4501

www.klingecorp.com

Manufactured by KLINGE CORPORATION

Service Request

Requests for Service should be directed to the Klinge Service Team. The below link should be used to place all requests for service and will afford the quickest response time.

<https://klingecorp.com/request-service/>

This form will help us determine model and age of the equipment, location, basic details about the issue, who to contact and how to best handle the issues with the equipment. A service ticket number will be provided in a response email once the form is received and processed. If the equipment is out of warranty, charges may apply for extensive technical support.

Additionally, our Service Department can be reached via email at technical@klingecorp.com.

Spare Parts Request

Requests for Spare Parts should be directed to our Parts Department via email at spares@klingecorp.com. Please have available at the time of the request the Serial Number of the equipment to ensure that the proper part is provided.

Use of this Manual

The use of this manual is intended for the safe operation of the equipment described. It is therefore reasoned that persons who have the occasion to use this manual have a knowledge of mechanical and electrical systems and components addressed by its' contents. However, efforts have been made to enable persons less familiar with these systems to use this manual.

The equipment may be installed in a number of configurations. Each may have optional items and differing external details provided by third parties. The specific electrical circuit and pipe diagram are posted on the unit as decals.

Most external and internal pipework parts are standard commercially available pipe fittings and not covered here. For external pipe fitting, replace like for like, taking care to replace stainless steel with stainless steel.

Suggestions as to improvement in content and format are welcome and should be addressed to engineering@klingecorp.com. Corrections and improvements will be included on dated revisions – the latest of which will be available upon request.

Table of Contents

Service Request.....	4
Spare Parts Request.....	4
Use of this Manual.....	4
1.0 GENERAL DESCRIPTION.....	7
1.1 Compressor.....	7
1.2 Chiller.....	7
1.3 Glycol Components & System.....	7
1.4 Refrigeration System & Components.....	8
1.5 Heaters (if equipped).....	9
1.6 Piping Schematic.....	10
2.0 OPERATION.....	11
2.1 Pre-starting Check.....	11
2.2 Starting Check.....	11
2.3 Running Unit.....	11
3.0 ELECTRICAL FUNCTIONS.....	15
3.1 General Information (Refer to Electrical Schematic).....	15
3.2 Electrical Box.....	15
3.3 Electrical Schematic.....	17
4.0 MICROPROCESSOR THERMOSTAT.....	19
4.1 General Information.....	19
4.2 Display Panel.....	19
4.3 Temperature Sensors.....	21
4.4 Microprocessor Thermostat and Data logger.....	21
4.5 Microprocessor Control Sequence/ Functionality.....	22
5.0 MAINTENANCE AND SERVICE INSTRUCTION.....	27
5.1 General.....	27
5.2 Safety.....	27
5.3 Checking Refrigerant Charge.....	28
5.4 Procedure for adding refrigerant.....	28
5.5 Non-condensable gases.....	29
5.6 Opening the System.....	29
5.7 Testing for Leaks.....	29
5.8 Evacuating the System.....	30
5.9 Glycol System.....	30
5.10 PTI Form.....	37

6.0	SERVICING COMPONENTS	38
6.1	Compressor	38
6.2	Condenser Fan Motor.....	40
6.3	Condenser Fan	41
6.4	Filter Drier Replacement.....	41
6.5	High Pressure Switch.....	41
6.6	Thermal Expansion Valve.....	42
7.0	TROUBLE SHOOTING.....	45
7.1	General Information.....	45
7.2	Service Components	45
7.3	Microprocessor Thermostat	45
7.4	Trouble Shooting Chart.....	46
8.0	SERVICE PARTS	51
	Suggested Spare Parts	80

1.0 GENERAL DESCRIPTION

This unit is specially designed for cooling heat transfer fluid, which is used to control the temperature of tank containers.

The machine is designed for uses in combination with ethylene glycol, propylene glycol, or synthetic oils where different cargoes dictate a different cooling medium. Ethylene glycol is commonly used with most chemical cargoes. Propylene glycol is used with foods and synthetic oils are used for high and low temperature cargoes. With due consideration for non-metallic pipe connections a mixture of diphenylethane and alkylated aromatics, can be used for very low temperatures if required.

The basic equipment of the standard configuration of the TCR-104 includes the following:

- a discus compressor using R-404A or R-452A,
- a plate chiller section,
- a circulating pump,
- provision for an optional 5kW heater (not fitted here)

A detailed description of the system follows.

An adjustable thermostat and two probes monitor the temperature of the cargo in the tank and the glycol system. The thermostat is then linked in the electromechanical system to control operation of the pump, compressor, suction-throttling valve, and fan.

The connection to the tank's circulating system is made with the necessary components, built into the tank and supplied by the tank builder.

1.1 Compressor

Compressor is a Copeland discus compressor, specifically designed for transport operation. The compressor is supplied with a deep oil sump to provide larger oil capacity. Protection from salt atmosphere is provided by a double coating of Pit guard paint. The compressor, which has been available since 1988, is rugged and has many new high-tech features. The shaft is impregnated with Teflon to provide lubrication should the compressor lose lubrication for a short period of time, the valve seats are made of a permeable material which permits the compressor to obtain optimum seating after the first 72 hours of operation.

1.2 Chiller

The chiller is a solid, brazed plate unit construction producing a very compact rugged heat exchanger. This stack plate type construction, using the very latest in continuous vacuum brazing technology, is more compact, efficient, reliable, and maintenance-free than ordinary units.

1.3 Glycol Components & System

The glycol system is a closed system. The glycol is not exposed to the air. This is accomplished by using a buffer tank with a bladder to allow for the expansion and contraction of the glycol as temperatures change. No air can get into the system, as would be the case with a naturally aspirated expansion tank.

Air in the system would promote corrosion and could get trapped. This could cause noisy, inefficient operation and energy waste. The result would be loss of pump performance and corrosion of equipment.

The bladder in the expansion tank has air or nitrogen on one side and system glycol on the other. The gas is pressurized to 0.8 Bar (12 psig). This maintains a system pressure of 0.8 Bar (12 psi).

The system has a fill valve set at 0.8 Bar (12 psi). This allows the system to be filled to exactly 0.8 Bar (12 psi) glycol pressure automatically. Each glycol system is equipped with an air purger and float vent which automatically purge the air out of the system and expel it into the atmosphere. This removes any air, which may be in the glycol when the system is filled. The system also has a safety pressure relief valve, which is set at 3.5 Bar (50 psi).

The glycol pump is powered by a 1½ H.P. TEFC motor at 3450 RPM. The motor is slightly oversized. At no time will the pump load exceed 1½ H.P.

1.3.1 Cleanliness of the Glycol System

New cooling systems are typically coated with oil, grease, or protective film during fabrication. Welding by products, flux and scale that would not normally cause a problem with a steam system can cause a problem with the glycol heat exchanger – the chiller.

Dirt will migrate to the chiller (a plate type heat exchanger) and may block the small gaps between each plate. Because of this, thoroughly cleaning the new system is important.

A solution of 1 to 2% trisodium phosphate can be used with water for flushing the cooling pipes. The system volume can be calculated at this stage by metering in the cleaning material.

This cleaning should be completed prior to connecting the TCR-104 unit.

We suggest that a gauze or muslin cloth be used to filter and observe the output of the cleaning medium. Use the lack of returning dirt as a guide to cleanliness.

NOTE: As it is an inherently closed loop system, the unit purposely does not have the restriction of an in-line filter in the glycol line and depends on the system being cleaned at the initial charge filling.

1.4 Refrigeration System & Components

In addition to the compressor and chiller the refrigeration system includes thermal expansion valve (TXV), drier, sight glass, condenser coil, receiver, pressure switch and heat exchanger/suction accumulator.

The suction pressure-regulating valve prevents the suction pressure from increasing above a pre-determined value. This prevents the compressor motor and engine generator set from being overloaded at pull down conditions on high ambient days.

The heat exchanger/suction accumulator prevents liquid slugging of the compressor and uses the cold suction gas to sub-cool the liquid line.

The receiver is equipped with (2) sight glasses. The bottom sight glass should be filled and the ball floating during normal operation.

1.5 Heaters (if equipped)

The immersion heaters are 3 phase heaters for operation on 480-volt 3 phase power. At 480 Volts, the power is 5kW. These heaters must be submerged at all times when in operation.

There is a safety thermal release permanently set to 110°C. If tripped this device opens all 3 legs of the heater assembly.

1.6 Piping Schematic

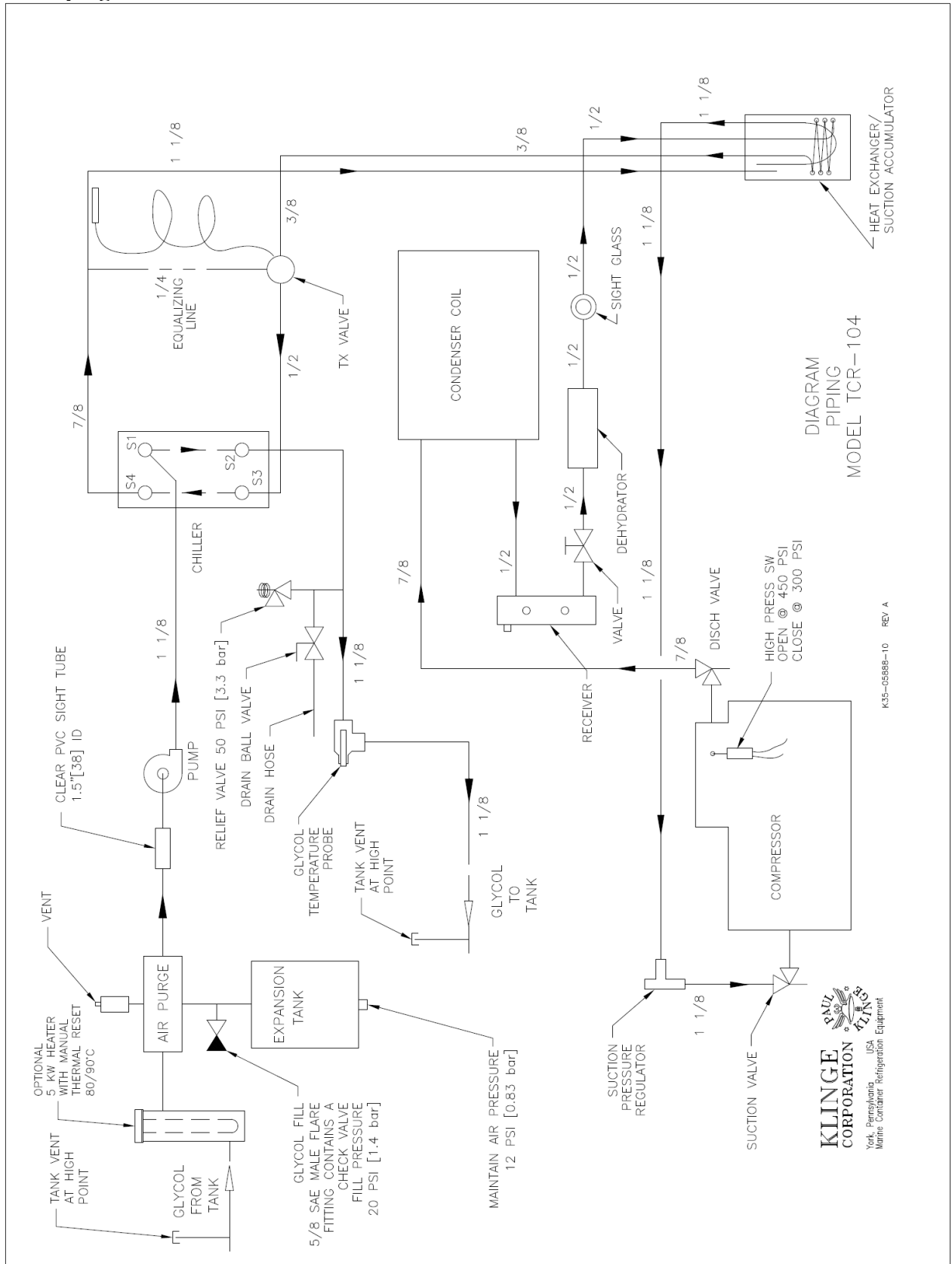

PIPING SCHEMATIC

2.0 OPERATION

2.1 Pre-starting Check

The following inspection should be made before the container is loaded as part of a pre-trip inspection. **All electrical power to the unit should be disconnected before inspection.**

1. Visually check unit for physical damage.
2. Visually check major hold-down bolts, door latches.
3. Visually confirm presence of glycol in clear sight tube between pump and expansion tank.
4. Thoroughly check all refrigerant and glycol joints and connections for traces of oil or glycol, which could be caused by a small refrigerant or glycol leak.
5. Open control box cover and check that all electric components are secure and that terminal connections are tight.
6. Check gasket on control box and make sure that the cover is safely closed.
7. Check cleanliness of condenser coil and clean if necessary.

2.2 Starting Check

1. Connect **MAIN POWER PLUG** into receptacle to supply power to unit.
2. Be sure CB1, CB2 and CB3 breakers are in the **ON** position.

Initiate Function Test — Hold test switch down and simultaneously switch unit **ON-OFF** switch to the **ON** position. Unit will now function test automatically.

After completion of function test (approx. one minute), check amperage of the compressor motor, condenser fan motor and glycol pump. At the same time, check all indicating lights and direction of rotation of condenser fan and glycol pump.

Adjust temperature set point to 0°C (32°F). Check refrigerant level in receiver sight-glass after approx. 15 minutes of continuous running with system fully loaded.

2.3 Running Unit

2.3.1 Phase Selection

The phase sensor monitors the three- phase system for phase sequence and unbalance due to phase angle and phase voltage deviations such as blown fuse or a bad connection.

When the unit's **ON/OFF** switch is put in **ON** position, power feeds into the phase sensor's changing device. When the phase sensor is energized, it scans the phasing of the input power and will allow either PC1 or PC2 to become energized to ensure the correct rotation of the fans.

2.3.2 Temperature Controlling (two probe system, thermostat program K35 00858)

There are two temperature control settings; the **cargo set point** and the **safety limit temperature** to prevent local “under cooling” (or “over heating”).

It is inherent in all conduction heating and cooling that the heat transfer medium must hotter or colder than the cargo being controlled. With many cargoes, this is not a problem but with certain cargoes, the

storage temperature is optimally very close to the temperature that freezing, crystallization, caramelizing, distillation/separation, and such non-reversible physical changes may occur. Local overcooling or overheating of the cargo at the point at which the glycol first comes in contact with the tank may be a problem with these liquids.

To allow the cargo to be set as near the optimum temperature as possible, the circulating glycol temperature as well as the cargo temperature is part of the control system.

Both temperature control settings are determined by the setting of the touch pad control panel. The sequence of events or cycles of the unit are governed by the controller in conjunction with the cargo and supply glycol temperature probes and the temperature control settings selected on the touch pad panel.

There are two possible control configurations depending on the cargo:

1) For normal for cargoes that are not sensitive to local “under-cooling” (or “over heating”) - the safety limit temperature can be set at a high value, effectively taking this feature out of the operation.

Cargo probe temperature 0.5°C (0.9°F) above set point will initiate cooling. The compressor will operate; the glycol pump will run; and the condenser fan will operate to draw air over the air-cooled condenser coil. At the set point the compressor and condenser fan motor will cycle off. The glycol pump will continue to run and circulate glycol. Cargo probe temperature 0.5°C (0.9°F) below set point will initiate heating. The glycol pump will run, and the heater will energize. At the set point the heater will cycle off. The glycol pump will continue to run and circulate glycol.

2) For cargoes that are sensitive to local “under-cooling” (or “over heating”) - the safety limit temperature must be set at a lower value, the minimum setting is 2.2°C (4°F). The lower the setting the more sensitive the unit will be to local “under-cooling” (or “over heating”).

With the safety limit set at a low value the above sequence will operate. However, if the glycol probe temperature exceeds the safety limit setting, the heating or cooling function will terminate until the circulating glycol temperature as determined by the glycol probe returns within the safety limit setting. The pump will continue to circulate the glycol.

Example: If the unit is cooling with set point at 15°C and the safety limit setting at 5°C , the safety feature will terminate cooling if the glycol probe senses a supply glycol temperature of 10°C or less ($15 - 5 = 10$).

If the unit is heating with set point at 15°C and the safety limit setting at 5°C , the safety feature will terminate heating if the glycol probe senses a supply glycol temperature of 20°C or more ($15 + 5 = 20$).

This is illustrated in the accompanying limit chart.

The temperature indicated by the LED touch pad is the cargo probe temperature. The probe is located in a bulb well in the container. The end of the probe should be against the bottom of the tank bulb well and the well filled with a conductive material like graphite grease.

2.3.3 Function Test (Use labels on right side of thermostat)

To initiate a function test, hold test switch down and switch unit **ON/OFF** switch to ON.

All indicator LEDs will flash, and the unit will then proceed through the following steps. Each step will last approximately 8 seconds.

- phase sensor and pump will come ON
- condenser fan ON
- compressor ON
- heater LED will come on (may be seen through the label if not heater equipped)
- Cargo probe LED will come on and the probe is tested for an open or closed circuit
- Glycol probe LED will come on and the probe is tested for an open or closed circuit
- the 8th LED will come on, but is not used in this application

If there is a problem at any of the steps the LED associated with that step will flash.

On successful completion of the test, the unit will return to normal operation.

2.3.4 Glycol Pump Heat

The energy of the pumping action is transferred to the glycol in the form of heat. Therefore, if for some reason the unit is not cooling it is best to turn the system off to avoid heating up the product in the tank from the heat from the pump.

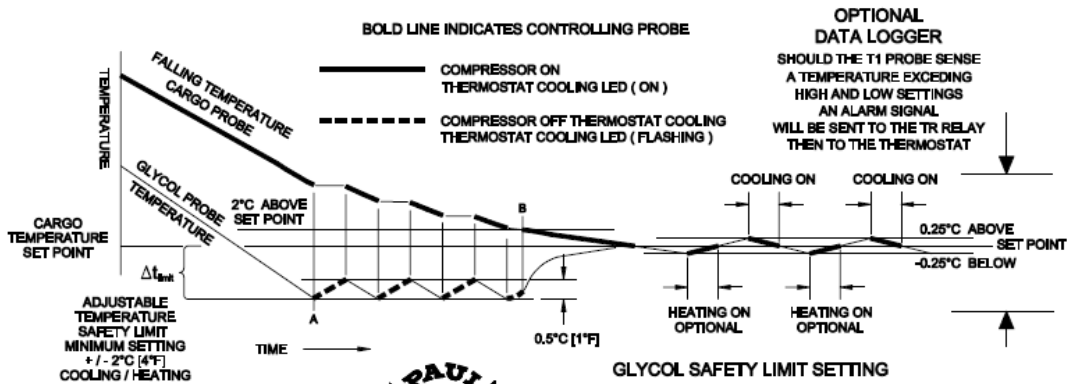
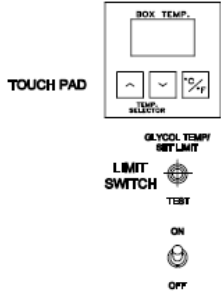

CHART IS SHOWING COOLING HEATING IS OPPOSITE THE CHART SHOWS THE RELATIONSHIP BETWEEN SET POINT, LIMIT AND WHICH PROBE (CARGO OR GLYCOL) IS CONTROLLING THE UNIT COOLING OR HEATING



NOTE
SHOULD THE CARGO PROBE FAIL THE GLYCOL PROBE WILL CONTROL THE UNIT

- OPTIONAL DATA LOGGER**
SHOULD THE T1 PROBE SENSE A TEMPERATURE EXCEEDING HIGH AND LOW SETTINGS AN ALARM SIGNAL WILL BE SENT TO THE TR RELAY THEN TO THE THERMOSTAT
- 1- THIS IS AN ADJUSTABLE TEMPERATURE LIMIT TO PREVENT THE GLYCOL FROM SUB-COOLING THE CARGO. IT SENSES THE DIFFERENCE FROM THE SET POINT TO THE TEMPERATURE SENSED BY THE GLYCOL PROBE.
 - 2 - WHEN THE TEMPERATURE DIFFERENCE IS GREATER THEN THE SAFETY LIMIT THE COOLING OR HEAT WILL SHUT DOWN AND THE THERMOSTAT COOLING OR HEAT LED WILL FLASH.
 - 3 - IF AFTER PULL DOWN AND THE SAFETY LIMIT IS EXCEEDED THE SEQUENCE FROM [A TO B] WILL REPEAT, PREVENTING LOCAL OVER COOLING OR HEATING.



TOUCH PAD and LIMIT SWITCH

- 1 - Touch pad shows, actual cargo temperature.
- 2 - Push \wedge or \vee keys on touch pad to see cargo temperature set point.
- 3 - To see glycol temperature hold the limit switch up.
- 4 - To see the Δt limit hold the limit switch up & press \wedge or \vee (minimum setting + / - 2°C [4°F])
- 5 - To reset Δt hold the limit switch up and press \wedge or \vee keys then to set the limit simultaneously hold \wedge and \vee for 2 seconds.

THERMOSTAT EDGE LED LIGHTS			THERMOSTAT DISCRPTION WHEN LED IS ON
#	LABEL	LED (LIGHT)	
1	ON	ON	12 VOLT POWER TO THE THERMOSTAT
2	ALARM ON	ON	AN ALARM IS PRESENT SEE 8, 9, OR 10
3	PRIMARY SYS	ON	USED FOR DUAL SYSTEMS ONLY ALWAYS ON WITH A SINGLE UNIT
4	COOLING	ON	THERMOSTAT IS CALLING FOR COOLING
		FLASHING	COMPRESSOR OFF (GLYCOL TEMPERATURE PROBE IS COLDER THEN THE SAFETY LIMIT SETTING)
5	HEAT OPTIONAL	ON	THERMOSTAT IS CALLING FOR HEAT
		FLASHING	HEAT OFF (GLYCOL TEMPERATURE PROBE IS WARMER THEN THE LIMIT SETTING)
6	CARGO	ON	CARGO PROBE IS CONTROLLING
		FLASHING	CARGO PROBE BAD (CONTROLLING ON GLYCOL PROBE)
7	GLYCOL	ON	GLYCOL PROBE IS CONTROLLING
		FLASHING	GLYCOL PROBE BAD (CONTROLLING ON CARGO PROBE)
8	TEMP FAIL	ON	1- PULL DOWN RATE IS LESS THEN 0.05°C [0.1°F] / HOUR 2- EXTERNAL TEMPERATURE FAULT SEE DATA LOGGER
9	HILO PRES	ON	COMPRESSOR HIGH PRESSURE SWITCH OPEN
10	MOTOR FAIL	ON	ONE (3) OF THE MOTOR CONTACTOR OVERLOADS HAS A FAULT

K35-06118-00 REV A GLYCOL SAFETY LIMIT CHART USE WITH THERMOSTATS K31-00858, K31-00878, K31-00888-10,-20,-30

LIMIT CHART
SHOWING THE OPERATION OF CARGO AND GLYCOL PROBES

3.0 ELECTRICAL FUNCTIONS

3.1 General Information (Refer to Electrical Schematic)

When high voltage power is being fed to the unit and CB1 is in the **ON** position, power will pass along L1, L2 and L3 to the compressor contactor, transformer, phase sensor and phase contactors. When the phase sensor is energized, PC1 or PC2 will be energized and allow power to the condenser fan contactor and glycol pump.

From this point the microprocessor thermostat will maintain the temperature. The microprocessor thermostat compares the temperature of the probe with the set point and calls for cooling when it is required.

All wires have numbers printed at both ends.

3.2 Electrical Box

3.2.1 Circuit Breaker

1. Circuit breaker. (**CB1**)

This 16 Amp circuit breaker is a 3-phase device. It is reset manually and protects the entire unit against overload. The breaker may be used as an OFF/ON switch.

2. Circuit breaker. (**CB2**)

A 2 pole, 4 Amp circuit breaker protects the 24-volt control circuit in case of possible short circuits.

3. Circuit breaker. (**CB3**)

A 2 pole 4 Amp circuit breaker that protects the 12-volt control circuit in case of possible short circuits.

3.2.2 Contactors

1. Compressor motor contactor (**C**)

This is a 3-pole 480 volt direct-on-line contactor with a 24-volt operating coil. It operates the compressor motor and is energized by the microprocessor thermostat. The 24-volt coil circuit can be interrupted by the high-pressure switch. Compressor has internal overload protection with automatic reset.

2. Condenser fan contactor (**CF**)

This is a 3-pole 480 volt direct-on-line contactor with 24-volt operating coil. It operates the condenser fan and is energized by the microprocessor thermostat. Condenser fan motor has internal overload protection with automatic reset.

3.2.3 Transformer

1. Transformer 480 24V/12V (T1)

The primary coil is tied into the line between the 16-Amp circuit breaker and the line starters. The secondary coil supplies 24 Volts AC for the control circuit and 12 Volts AC for the thermostat power.

3.2.4 Phase Sensor (PS)

When the unit has proper voltage and frequency, it automatically selects correct phase rotation. By putting the unit ON/OFF switch to the ON position, 24 Volts will pass to pin no. 5. The phase sensor will switch the 24 Volts to pin 6 or 8 to give the motors the proper rotation.

Test procedure of phase sensor:

1. Put the unit **ON/OFF** switch to **ON** position.
2. Check that the light emitting diodes (LED) are lit for L1, L2, L3, or for L3, L2, L1.
3. Check the rotation of the fan motors.
4. Press **TEST** button on phase sensor for a minimum of 20 seconds.
5. Ascertain the LED lights go out and the other LED lights go on.
6. Check the rotation of the condenser fan motor and glycol pump. (They should reverse.)
7. Release the **TEST** button.

3.2.5 Phase Contactors (PC1 or PC2)

The phase contactors are two 3-pole 480-volt contactors with 24-volt operating coils. These connect the power to the condenser fan contactor and glycol pump. The contactor (PC1 or PC2) is energized by the phase sensor. There is a mechanical interlock between PC1 and PC2, so they can't be pulled in at the same time (electrically or physically).

3.2.6 Glycol Pump Overload Relay

There is a 3-pole relay to protect the glycol pump motor from overload. It is adjustable from 1.6 to 2.5 amp. For this application the relay should be set for 2.5 amp.

3.3 Electrical Schematic

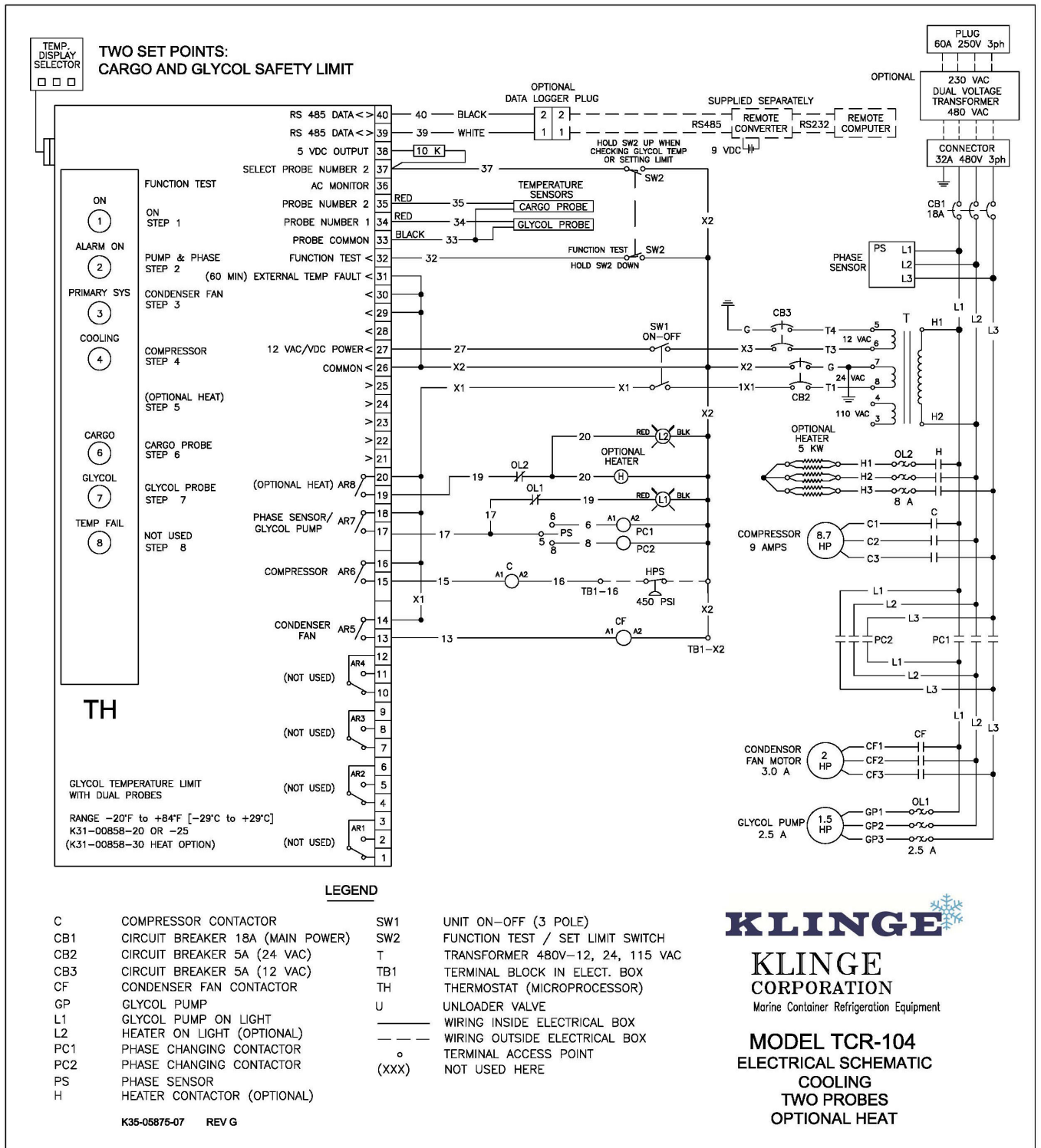

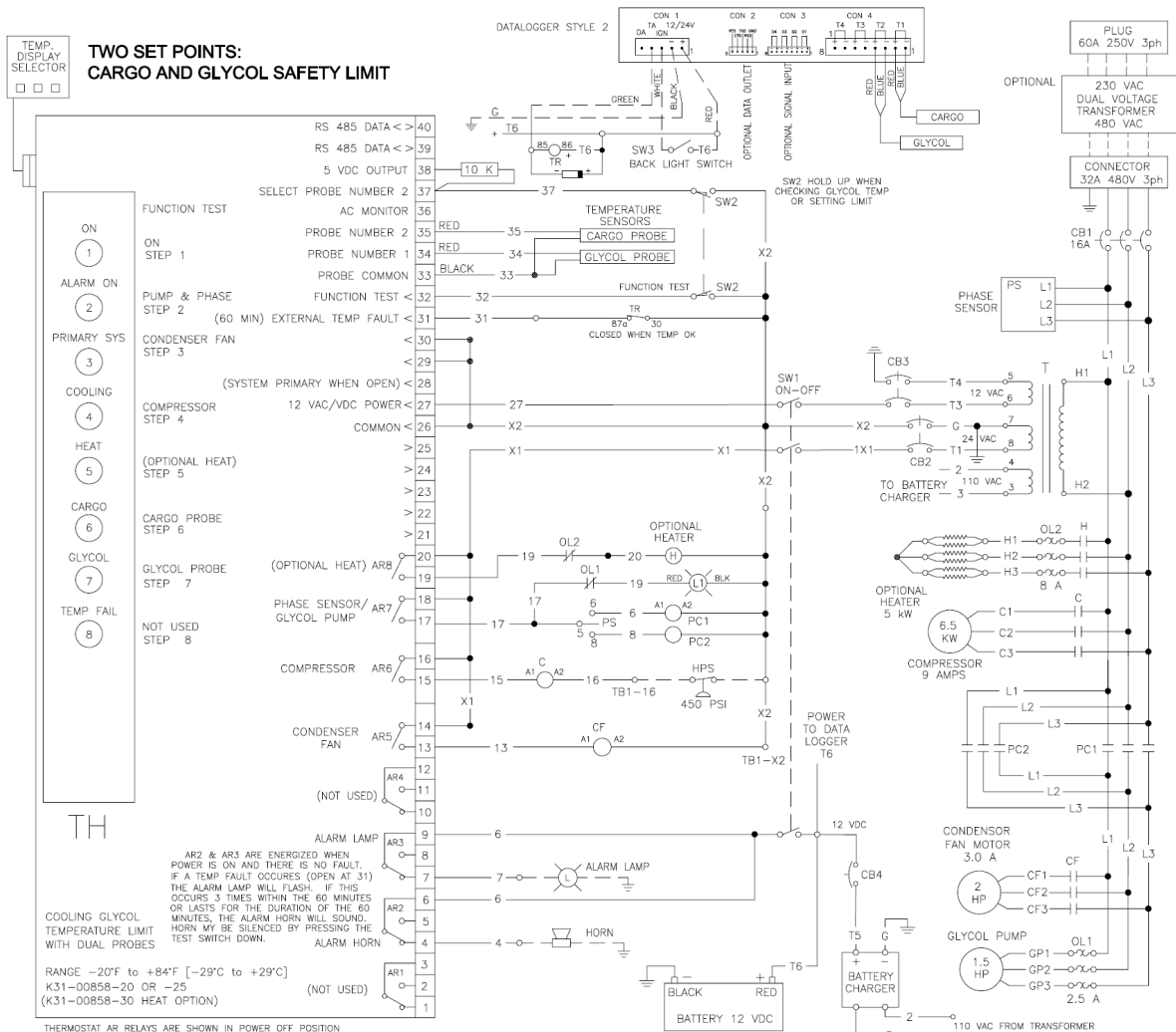

- LEGEND**
- | | | | |
|-----|----------------------------------|-------|----------------------------------|
| C | COMPRESSOR CONTACTOR | SW1 | UNIT ON-OFF (3 POLE) |
| CB1 | CIRCUIT BREAKER 18A (MAIN POWER) | SW2 | FUNCTION TEST / SET LIMIT SWITCH |
| CB2 | CIRCUIT BREAKER 5A (24 VAC) | T | TRANSFORMER 460V-12, 24, 115 VAC |
| CB3 | CIRCUIT BREAKER 5A (12 VAC) | TB1 | TERMINAL BLOCK IN ELECT. BOX |
| CF | CONDENSER FAN CONTACTOR | TH | THERMOSTAT (MICROPROCESSOR) |
| GP | GLYCOL PUMP | TR | TEMPERATURE RELAY |
| L1 | GLYCOL PUMP ON LIGHT | — | WIRING INSIDE ELECTRICAL BOX |
| PC1 | PHASE CHANGING CONTACTOR | - - - | WIRING OUTSIDE ELECTRICAL BOX |
| PC2 | PHASE CHANGING CONTACTOR | o | TERMINAL ACCESS POINT |
| PS | PHASE SENSOR | (XXX) | NOT USED HERE |
| H | HEATER CONTACTOR | | |
- REFRIGERANT R-404A
 360-15134-09 BOX COMPLETE
 30 JUNE 2004 SCHEMATIC SO 100412
- K35-05875-09 REV B**



MODEL TCR-104-09
ELECTRICAL SCHEMATIC
COOLING AND HEATING
TWO PROBES
ALARM HORN & LAMP
EXTERNAL DATALOGGER

4.0 MICROPROCESSOR THERMOSTAT

4.1 General Information

The microprocessor thermostat is an electronic solid-state device consisting of three parts:

1. The microprocessor board.
2. The cargo and glycol temperature probes
3. The display panel.

All parts are mounted in the control box except the temperature probes, one of which is mounted in the bulb well in the container tank and the other in or on the glycol pipe outlet from the machine.

Accuracy is +/- 0.1°C (0.2°F). Checking of temperatures should be done with equal or better accuracy.

Indicator LEDs are provided to indicate functions and as an aid to servicing the unit. The indicator LEDs are mounted on the thermostat and are visible from the front of the unit. The LEDs indicate the function being called for by the microprocessor thermostat.

4.2 Display Panel

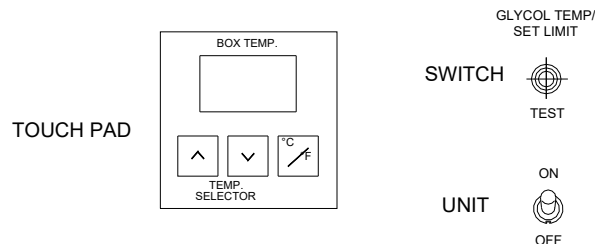

4.2.1 General Description

The display panel consists of three touch pad switches and a three-position numerical LED. See drawing of the front panel. The display normally displays cargo temperature as derived from the cargo probe in the tank. The glycol probe temperature can be seen by pushing the switch (GLYCOL TEMP) up. (see below and on the door for instructions.)

The temperature settings (set point & safety limit) are stored in a nonvolatile memory and will always be intact — even in case of power failure.

In order to prevent false entry or changes of values, both selector buttons must be depressed simultaneously for new settings to be entered into the memory.

4.2.2 Reading and creating a temperature set point

For normal operation, the display indicates the cargo probe temperature.

The thermostat can operate in either Fahrenheit (°F) or Celsius (°C). When temperatures are displayed in the Fahrenheit scale, the figures are marked with a point at the end (example 20.) Temperatures displayed in the Celsius (°C) scale are not followed by a point (example 20).

Pressing the C/F key one time cause the display to indicate the current temperature scale.

An “F” or a “C” in the right character of the display indicates this.

Pressing the C/F key twice causes the scale to change. After five seconds the display returns automatically to “normal mode” and will indicate the cargo temperature.

Pressing the UP ▲ or DOWN ▼ key causes the display to show the current set point.

Each pressing of one of these keys will increase the display by one whole degree in the scale being used.

Holding a key pressed will cause the display to change by one-degree each half second.

To save a desired set point simultaneously press both UP ▲ and DOWN ▼ keys.

The new created set point will be in use until another set point is chosen. It will be maintained even if power is removed from the thermostat.

The display returns automatically to “normal operation” and will indicate the cargo temperature within 5 (five) seconds after the last key has been pressed.

Setting the Glycol Safety Limit

This is set in the same way as the set point, but first hold up and continuing to hold up the GLYCOL TEMP/ SET LIMIT- TEST switch.

Then touching either the up or down key will display the safety limit setting.

Press the UP ▲ or DOWN ▼ key to select the desired safety limit setting.

To save a desired limit simultaneously press both UP ▲ and DOWN ▼ keys.

On releasing the GLYCOL TEMP/ SET LIMIT- TEST the display returns automatically to “normal operation” and will indicate the cargo temperature within 5 (five) seconds after the last key has been pressed.

Note: consult the cargo manifest. If there is no requirement for limiting “under-cooling” first check the previous setting by holding down the GLYCOL TEMP/ SET LIMIT- TEST switch and read the limit. If necessary, make this a larger range for example 15. This will then allow the machine to operate without restriction.

4.3 Temperature Sensors

Each temperature sensing probe is a thermistor placed in a sealed metal tube, which is connected to a two-conductor shielded cable. The temperature signal from the probe is connected to the microprocessor board through this cable. The probes are labeled CARGO and GLYCOL but other than length, they are both the identical sensors.

If a probe or cable becomes defective, check the probe assembly and the thermostat connection first to confirm a shorted or open circuit. Then disconnect the probe to determine whether the probe or cable is defective.

WARNING:

It is important that the sensors are properly mounted and functioning. Use an ohmmeter to check probes. Zero Ohms resistance indicates a short circuit. An open circuit is indicated by infinite Ohms resistance. Good readings should agree with the chart below:

PROBE RESISTANCE CHART		
Probe at Ambient Temperature		K-Ohms (Approx.)
°C	°F	
+ 25	+77	10.0
+ 20	+68	12.5
+ 15	+59	15.7
+ 10	+50	19.9
+ 5	+41	25.4
0	+32	32.6
- 5	+23	42.3
- 10	+14	55.3
- 15	+5	72.9
- 20	- 4	97.0
- 25	-13	130.2

4.4 Microprocessor Thermostat and Data logger

4.4.1 General Description

This device contains all circuits necessary to select those functions required to maintain an accurate temperature. The selection is based on signals received from the probes and the display panel. It is designed to operate in ambient temperatures of -40°C (-40°F) to 49°C (120°F). Depending on the limit of the glycol used it will control temperature settings (set point) of -20°F (-29°C) to 29°C (84°F) to an accuracy of ±0.1°C (0.2°F).

4.4.2 LED Indicators

The narrow edge of the thermostat contains LED indicators. These LEDs serve a dual purpose.

1. The label on the front of the thermostat is for normal operation and indicates the operating status of the unit.
2. The side label is used for the function test. It indicates which function is being tested.

4.4.3 Inputs

Inputs signals to the device consist of:

1. Glycol probe temperature
2. Cargo probe temperature
3. Set point (temperature setting from display panel)
4. Safety limit setting
5. Signal from Switch 2 – up for glycol temperature/safety limit setting & down for Function test

4.4.4 Outputs

Output signals from the device are by means of 8 relays. 4 relays are single pole single throw normally open and 4 are single pole double throw.

Each output relay has a small red **LED** mounted on the circuit board adjacent to it, which indicates if the relay is energized.

These diagnostic **LEDs** are visible only from the side of the device and are for troubleshooting purposes only.

Outputs used in this system are:

1. Compressor ON (cooling)
2. Condenser fan on
3. Phase sensor ON (for glycol pump)
4. Heat Contactor (if equipped)
5. Connection for Data stream to an external computer to record the data logger (if equipped)

4.5 Microprocessor Control Sequence/ Functionality

The thermostat control sequence is outlined in the following diagram.

THERMOSTAT CONTROL SEQUENCE

FALLING TEMPERATURE

RISING TEMPERATURE

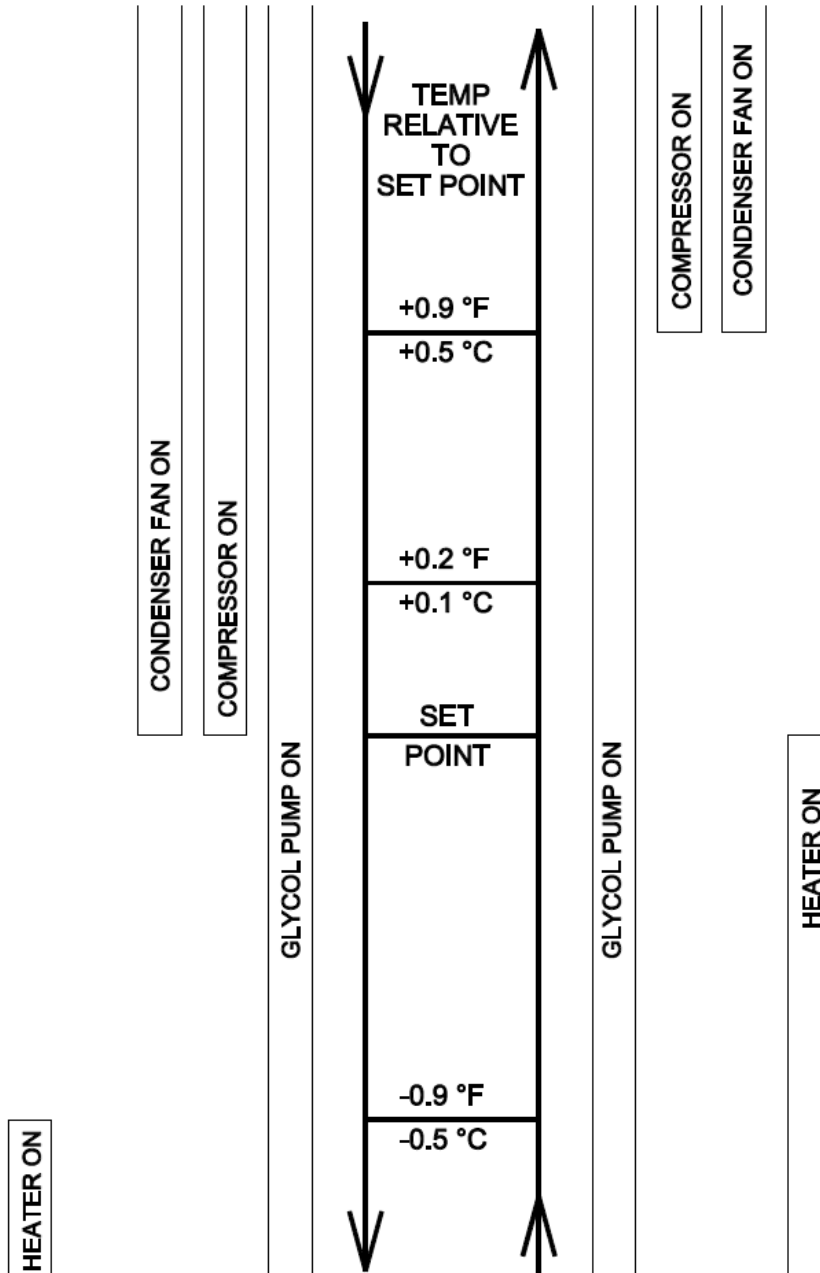

4.5.1 Temperature Falling

1. Compressor cycles off at set point.
2. Heat cycles ON at 0.5°C (0.9° F) below set point. (Optional)

4.5.2 Temperature Rising

1. Heat cycles off at set point. (Optional)
2. The compressor cycles ON at 0.5°C (0.9° F) above set point. The compressor has a one-minute off delay before it can cycle ON again, regardless of the temperature rise.

Remember Cooling or Heating is inhibited when glycol temperature is outside the safety limit setting.

4.5.3 Function Test (Label on right side of thermostat)

The thermostat is provided with an automatic function test, which energizes the glycol pump, condenser fan, compressor motor, heater (if equipped), and tests the cargo and glycol probes for open or shorted circuits.

During the function test, refer only to the label on the side of the thermostat.

Hold the test-switch down and switch unit ON/Off switch to ON, to initiate a function test. The microprocessor will automatically, step by step pass through the different stages listed on the side label.

- Step 1 All LEDs flash, the green ON LED remains on
- Step 2 Glycol pump test. Glycol pump will run; Pump & Phase LED will light
- Step 3 Condenser fan test. Condenser fan will run; Condenser Fan LED will light
- Step 4 Compressor test. Compressor will run; Compressor LED will light
- Step 5 Heater test. Heater contactor will activate, Heat LED will light (if equipped)
- Step 6 Cargo probe test. Cargo Probe LED will light
- Step 7 Glycol probe test. Glycol Probe LED will light
- Step 8 Not used for this application, but the Step 8 LED will still light

For a properly operating thermostat, each step, as outlined above, will last about 8 seconds then the controller will proceed to the next step.

If a problem is detected at any of the function test steps, the LED corresponding to that step will flash.

After Step 8 of the function test is executed, the controller will automatically reset and begin normal operation.

4.5.4 Other Functions

1. If the temperature pull-down rate is less than 0.05°C (0.1°F) per hour. The alarm LED will light, and the temperature failure LED will flash. This function is locked out within +/- 2°C (3.6°F) of the set point or if the set point has been reached.
2. After reaching the set point, if the temperature varies more than +/- 2°C (3.6°F) from the set point for more than 120 minutes, the alarm LED will light, and the temperature failure LED will light.
3. If the temperature reaches the set point the alarm LED indicators will reset. The alarm LED indicators may also be reset by turning the system control power off.

4.5.5 Optional Thermostat Data Logger Software

Requires K31-00888-10 software and a DOS interface program

Before attempting to use any of the features of the program you need to follow the first three steps:

- 1) Connect Download Cable to converter and plug into serial port on computer.
- 2) Start up program named Tcom.exe on your computer/laptop. Press #6 to toggle between the two COM Ports on your computer.
- 3) Select the proper COM Port that the converter is plugged into. The COM port that is currently selected shows up in the upper left corner of the program.

Setting thermostat information:

Press M to see a list of Thermostats that are able to work with this software, then select the number beside the thermostat model that the reefer unit has installed in it.

Press #3 this will set the Thermostats time and date to that of the computer.

Press #4 and enter the serial number you would like to us to recognize this unit. When finished press Enter.

Press #5 to read what serial number you entered.

Download procedure:

Press M to see a list of Thermostats that are able to work with this software, then select the number beside the thermostat model that the reefer unit has installed in it.

Press D to toggle to the degree mode that you want the data downloaded to.

Press #1 to select the download function.

Then enter a file name that you want the data saved as, then press Enter, this will start the download procedure. When this is finished, it will say download successful.

You then go into Word Pad, find the file, and open it.

Initializing (empty) thermostat data log:

Press M to see a list of thermostats that are able to work with this software, then select the number beside the thermostat model that the reefer unit has installed in it.

Press #2 to erase all data in the Thermostat.

WARNING:

THIS FUNCTION WILL ERASE ALL DATA THAT IS STORED IN THE CHIP

4.5.6 Thermostat Alarm strobe lamp and Alarm horn (Optional -09)

When an external fault (an open circuit) occurs at thermostat terminal 31 the alarm lamp will light and an internal 60-minute delay initiates. If the fault lasts for the duration of this delay, the alarm horn will activate. The horn can be silenced by pressing the test switch down; this allows the technician to work with out the noise.

When a fault (terminal 31 open) first occurs the alarm lamp will come on, as well as the Alarm LED and Temp Fail LED of the thermostat. If the fault corrects, before the 60 minutes, the alarm lamp, Alarm LED, and Temp Fail LED will turn off. If a second fault occurs within the 60 minutes the same thing will happen. Should the fault occur three times within the 60 minutes, the alarm lamp and alarm horn will come on, as well as the Alarm LED and Temp Fail LED of the thermostat

The alarm circuitry is shown on rev B of the electrical schematic.

The external temperature fault alarm can be tested as follows (Refer to schematic rev B):

On thermostat line 31 relay TR terminal 87a wire 31 push-on terminal can be removed (the voltage at this area is 12 VDC)

This open contact will cause an external temperature fault. When you remove the wire the alarm lamp will be on. After 15 seconds reattach the terminal and the lamp will go out (allow 15 seconds with the terminal on) do this a second time. When this is repeated the third time, the alarm lamp and alarm horn will come on.

The alarm circuit will also be activated internally by the thermostat should the pull-down temperature rate of the cargo be less than 0.05°C (0.1°F) per hour.

5.0 MAINTENANCE AND SERVICE INSTRUCTION

5.1 General

This section provides procedures for establishing preventative maintenance and systematic servicing schedules, which are the keys to successful operation.

All service and maintenance procedures should be performed in accordance with Montreal protocol or national equivalent of the American Section 608 of the Clean Air Act. This prohibits the venting of refrigerants into the atmosphere and requires the use of refrigerant recycling and recovering equipment to be used whenever a system is opened.

5.2 Safety

When any work is to be done on the components of the refrigeration system, always make sure that the equipment cannot be started automatically or accidentally. If valves are closed and/or circuits interrupted during service procedures, the control switches should be suitably tagged with such notations.

Beware of high voltage in various parts of the unit, especially when CB1 is on. To determine where high voltage will be encountered before electric power is applied to the unit it is recommended that a thorough study of the wiring schematic be made.

Do not exert excessive pressure when tightening flare nuts, as it may result in a rupture of the flare or stripped threads.

Always wear approved goggles or eye shields when working with refrigerant to prevent eye injury if refrigerant is accidentally discharged into the face of the service engineer.

Never, under any circumstances, apply heat to a refrigerant cylinder by using a naked flame. Should it be considered necessary to apply heat to a cylinder to create a refrigerant flow when recharging a system, place the cylinder in a container of hot or warm water to a point about 3/4 of the height of the cylinder.

Even this method requires that a pressure gauge is in use in the charging line to indicate the pressure in the cylinder at all times.

Also, never close the shut-off valve in the cylinder while the cylinder is being heated.

The use of a manifold gauge set will permit compliance with having a gauge in the line and a shut-off valve on the manifold to stop the flow of refrigerant into the system and allow the gauge to read cylinder pressure.

Always replace refrigerant cylinder valve and connection caps after using the cylinder, and do not permit a cylinder to be dropped or hit severely by another object.

Due to the height at which the refrigeration unit is sometimes placed in the container, always use safe and secure means to service the unit and to allow a platform for tools and a refrigerant cylinder.

CAUTION:

A gauge manifold should always be used when charging unit with refrigerant.

Warning:

Refrigerant is heavier than air. Therefore, it settles in the lowest places and will expel air (oxygen) from a small, confined space, resulting in dizziness or suffocation to an occupant.

5.3 Checking Refrigerant Charge

The receiver sight glasses are equipped with a ball which floats when the liquid level is in the sight glass or above.

It should be noted and remembered that the only requirement of liquid level is that a seal be maintained at the outlet of the receiver. At low ambient temperatures, approximately 10°C (50°F) and below, the liquid refrigerant may not accumulate in the receiver to a point where a liquid level will show on the sight glass. Many times, the liquid will hang up in the condenser. Therefore, caution should be taken before adding refrigerant. Air in the receiver may also prevent the level from coming up into the sight glass. Purging the air from the system can rectify this.

If the ball is not floating, it is recommended that the suction and discharge pressure be checked before determining that the charge is low. It is just as possible to do harm to the system by overcharging as it is to run it under charged.

It is important to have the correct amount of refrigerant in the system. If there is too little, the expansion valve will pass vapor and reduce the capacity of the chiller. Too much refrigerant will result in higher head pressures and reduced capacity.

While running the unit at the refrigerant checking state you should have a suction of 25 psig (+/- 5) and a discharge of 225 psig (+/- 25).

Note: The suction and discharge pressure should be measured at the valves on the compressor for the most accurate reading.

Check the refrigerant level at 0°C (32°F) glycol temperature with unit fully loaded.

Before adding refrigerant, always determine the reason for the low charge and remedy the cause. Leak test thoroughly with an electronic leak detector and also check for traces of oil.

5.4 Procedure for adding refrigerant

To add small quantities of refrigerant to the system, it is preferable to add gas to the low or suction side of the system. This will allow the system to operate with little or no disturbance of the refrigeration cycle while the refrigerant is being added.

Care should be taken to ensure that only gas is extracted from the refrigerant cylinder when charging into the low side.

- a. Remove the compressor suction service valve cap and back seat the valve. This closes the charging port. Remove the cap from the port and loosely attach the suction gauge line of a manifold set. Connect the center charging line to refrigerant cylinder and tighten the connection.
- b. Crack open the refrigerant cylinder valve and the manifold suction gauge valve and purge the air from the line. Then tighten the connection at the compressor suction service valve.
- c. With the system still operating and the suction pressure of 2 Bar (30 psig) or below, and the cylinder pressure at 12 Bar (170 psig) (dependent upon ambient temperature), open the refrigerant cylinder valve and the manifold suction gauge valve completely. Open the compressor suction service valve 1 to 2 turns.
- d. Allow refrigerant into the system and observe the receiver sight glass.
- e. If the pressure in the refrigerant cylinder equalizes the suction pressure of the system, charging will cease until the cylinder pressure is raised by heating it. To do this, a container of hot water or an electric blanket (made for this purpose) can safely be used.
- f. If the pressures equalize and no heating is available, partially front seat the compressor suction service valve and allow the system to pump down to a pressure slightly below the cylinder pressure. This will create a pressure difference between the system and the cylinder, allowing refrigerant to flow again. However, remember to close the cylinder or manifold valve before opening the compressor service valve, or refrigerant will be forced back into the cylinder. Also, the system should be allowed to cycle for at least 5 minutes after each shot of refrigerant to allow it to settle down so that an accurate reading can be taken at the receiver sight glass.
- g. When it is determined that the system has an adequate refrigerant charge, close the refrigerant cylinder valve (if not already closed), and the manifold suction gauge valve, and back seat the suction service valve, in that order. Remove the manifold lines and replace caps securely.

5.5 Non-condensable gases

Air and non-condensable gases in any system gather in the receiver above the liquid. This will result in above normal discharge pressures. These gases can be removed during operation by purging through the valve provided for this purpose at the receiver. To purge, use recycle equipment and open valve a small amount. Note any significant difference from the initial pressure when the valve is again closed. Repeat the operation until the discharge pressure is normal.

5.6 Opening the System

Whenever it is necessary to open a charged or functioning system to make repairs or replacements, it is necessary to comply with CAA by using recovery and recycle equipment.

The use of "EASY FLOW" silver solder and flux, or equivalent, is recommended in the refrigerant system piping. Do not use soft solder.

Prior to disturbing any connections, the type of solder originally used should first be verified, then continue. By taking this precaution, the contamination of the joint will be avoided.

5.7 Testing for Leaks

The preferred method for finding leaks is by use of an electronic leak detector. There are several different makes available, and they all use the same method of detecting a leak through an exploring tube which will detect from large to extremely small leaks depending on the setting used on the detector.

Leak testing with soapsuds will reveal only the large leaks and is therefore ineffective in determining the tightness of a system.

5.8 Evacuating the System

Caution:

Do not use the compressor as a vacuum pump or as an air compressor. It is not designed to handle air and will not pull down to as low a vacuum as a pump designed for that purpose. Similarly, if used to compress air, serious overheating and consequent damage may be the result.

Connect a pump capable of drawing a vacuum of .15 mm Hg or better to that part of the system which has been opened. Continue until all air and moisture has been removed.

The final evacuation may be accelerated, however, by “manifolding” the connections to the vacuum pump and evacuating simultaneously the high and the low sides of the system; the vacuum should be broken by introducing refrigerant.

Too much emphasis cannot be placed on the importance of keeping the system free of moisture. Slight amounts of water in the system will inevitably lead to trouble in the following forms:

- a. Corrosion of steel parts.
- b. Copper plating of the shaft and bearing.
- c. Sludging or gumming of the oil.
- d. Plugging of the strainers and driers.
- e. Freezing and plugging of expansion valve.

Whenever it is necessary to open the system for any reason, always take precautions to prevent the entrance of air into the system, as air always contains some water vapor. Isolate as much of the system as possible from the portion to be opened by closing suitable valves.

5.9 Glycol System

5.9.1 Glycol System and Air

On this model the glycol system is a closed system, the glycol is not exposed to the air. No external air should get into the system. A small amount of gas will be in the system in the form of small air bubbles, but most will reabsorb as it passes through the pressurized pipe work.

Air in the system at colder temperatures causes the glycol to become thicker and the air could collect into a large bubble at high spots in the glycol system and block the glycol flow.

When the heater is used and there is a low glycol level in the system containing a small amount of air in the system, it could occur that the air collects at the pump inlet causing the pump to cavitate. The

glycol may not circulate, and this could cause the glycol probe to not read correctly. Should the heater could continue to heat in this condition it will cause excess heat and pressure and components to fail.

The main part of the system is the pump, chiller, air separator, air vent, relief valve, fill valve and the expansion tank (which accommodates the glycol which will expand and contract as the temperature changes) plus the piping system around the tank.

Note: The thermostat temperature limit setting only monitors the glycol probe and the set point and requires that the pump to be circulating glycol throughout the system.

5.9.2 Air Trap and Vent

The air trap is located on top of the air separator which is back of the control box. There is a Schrader (tire type valve) vent back of the control box on the top of the air separator. This provides a port to expel air, but it must be operated manually.

Venting at this point should be done at each pre-trip.

Depending on the tank's cooling system there may be additional vent points in the upper runs of the cooling system. Klinge advises that they are fitted to the tank's pipe work but are not always notified of the details.

5.9.3 The Glycol

The circulating system is simple in design and in operation. As the pipe work is designed as a closed system there is no requirement for an inline filter. If, however, on initial charging of the system, or in service, the system could be contaminated with solid matter, it will collect at the chiller and restrict the flow and therefore the capacity of the system. If this happens the chiller may be reverse flushed with high-pressure, high-volume liquid such as wet steam.

Caution: Only clean glycol should be added to the glycol system. The glycol should be checked, and compatible glycol added.

Invariably the volume of the cooling system is not known to Klinge Corporation. However, generally the volume of glycol for these units, when fitted on a 20,000-liter ISO tank would be 30 ~ 35 or more US gallons. We recommend that for a new installation or a repair after a catastrophic loss that a 40 US gallon barrel of pre-diluted glycol be used to fill the system.

Usually, the coolant is an ethylene glycol based industrial or propylene glycol a food grade heat transfer fluid (Caution: the different glycols should not be mix). It is water-soluble and has built in corrosion inhibitors and is compatible with other glycol fluids of the same type. The combination of a closed system and corrosion inhibitors in the glycol permit a longer glycol life.

The condition of the glycol is also important, it is suggested that each year the pH (acid level) should be checked (a pH of 7 or above is recommended). The ratio of glycol to water is to 50-50 or 60 glycol to 40 water. This should be checked with a Refractometer or a less accurate hydrometer.

5.9.4 Initial Filling

Adding glycol to a tank container that has no cargo in will be faster and easier.

It may be expedient to break the pipe work at one or two points to add the initial charge of glycol by gravity and allow the air to escape at another point.

After the filling operation is complete the pump (only) should be allowed to run. Set the unit set point the same as the cargo temperature and allow the unit to operate (the compressor should not run). Observe the glycol through the translucent hose at the pump suction inlet. The inlet sight tube should be full of glycol and there should be very few air bubbles in the system. When the system appears to be full, (no bubbles) continue to run the pump for approximately 15 minutes longer. Observe the glycol flow during this period, it should be steady.

There is a venting port above the air separator on the suction side of the pump, this small air tank has a Schrader valve located on top and the valve may be removed to aid filling and venting (see attached sketch for a fill tool). The unit can be filled through this pipe. Adjust the set point to be the same as the cargo temperature. This will allow the pump (only) to be run at this time to aid the charging of glycol and removing air. Allow this fill tool to remain open to the atmosphere allowing the air to escape. This pipe on the fill tool should always contain glycol to prevent air from being pulled back into the system.

The pump is not self-priming and relies on the coolant as a lubricant, so it should not be run dry.

If glycol is added at the fill valve, a pressure of 1.4 Bar (20 psig) is required.

If glycol is added at another spot, then the air vent on top of the air separator will manually need to be purged by depressing the Schrader valve often or remove the Schrader valve and use a fill tool.

Caution: This air purging must be done properly. There may be a lot of air in the form of small bubbles that will need to be removed. Air removal may take some time and should be done as completely as possible, because air in the system could cause the pump to cavitate (air at the inlet) and not push the liquid through the system.

Caution: The systems that have heaters require extra attention to the quantity of glycol in the system. If the level is low an air pocket could form at the pump inlet. At this time the pump will not pull glycol through a heater that may be operating. This would create excess heat and pressure and could cause damage to the system.

When it has been determined that most of the air is out of the system the glycol system can be closed.

5.9.5 The Glycol Fill Valve

The fill valve is located between the air separator and the expansion tank. When the system is closed glycol is added through this fill valve which has a connection with 5/8 SAE x 45-degree male flare fitting with 7/8"- 14 threads/inch.

The fill valve will require 1.4 Bar (20 psig) or more pressure to open the valve to allow glycol to be added to the closed system. The fill valve has a check valve and only allows filling at this location.

Note: The fill valve will only allow glycol to be added to the system not the expansion tank.

5.9.6 Adding Glycol to the Closed System

Note: Some type of pumping device will be required for this charging operation. For proper filling of glycol there should be no cargo in the tank.

The fill hose should be connected and under pressure during the charging process.

Turn the unit on and set the temperature set point to -30°C or (-20°F).

As the temperature falls the glycol will contract and allow the glycol to be pushed into the system, and when it nears the set point, check the translucent hose for bubbles.

Run the unit on cooling for over 1 hour – the glycol pipe from the chiller outlet should be noticeably cooler. The refrigeration pipe at the expansion valve may frost up. This is normal – however, excessive icing indicates either a blockage in the chiller or if there is no glycol flow.

The tank system has numerous vent points that can be used to remove air from the glycol system.

If the tank is loaded with a product, it may not be possible to pull the glycol down to -30°C (-20°F). In this case, pull the unit down until the pull-down rate slows down. Replace the vent cap.

Note: In case of an emergency and glycol needs to be added to a full system and the fill valve will not allow the adding glycol; a refrigerant hose with valve depressor can be used on the Schrader valve fitting on top of the vent reservoir.

CAUTION: only a small amount of glycol 1/2-gal max. [2 Liter] should be added when the glycol is cold, as when the system becomes warm excess glycol may exceed the capacity of the expansion tank and will be relieved through the relief valve.

5.9.7 The Expansion Tank

The expansion tank contains a flexible bladder and is used to contain the greater volume of glycol as the temperature rises.

The bladder in the expansion tank has air or nitrogen (N₂) on one side and system glycol on the other side. The pressure is checked at the Schrader valve on the bottom of the tank. This gas side is to be adjusted to 0.8 Bar (12 psig). This maintains a system pressure of 0.8 Bar (12 psig).

This is a pre-set charge and is not normally adjusted.

This tank contains a plate on the top side of the bladder with a valve stem that protrudes past the mounting threads. This presses on valve in the fill valve controlling the flow in the fill valve.

Only gas should be in the tank, if glycol comes out of this valve it indicates the bladder has failed and the gas charge has been lost. Running the unit in this condition could cause a failure. Contact Klinge Corporation or e-mail engineering@klingecorp.com for specific directions and reeferparts.com for spare parts.

5.9.8 The Safety Valve

The system also has a safety pressure relief valve, which is 3.5 Bar (50 psig).

5.9.9 The Pump

The pump is not self-priming and relies on the coolant as a lubricant, so should not be run dry. However, it may be run intermittently in the initial filling stage to assist in venting the system. The pump, being a moving part has a service life estimated at 4 to 5 years life of regular service in one way trade. There is a replacement kit of bearings and seals for in-service replacement. Quote the serial number of the unit when ordering the in-service kit.

5.9.10 Air Blockage at Colder Temperatures

At ambient temperatures and with 12 psig of pressures, a small amount of air trapped in the system may freely flow around the system in a pattern of small bubbles. These will be visible at the sight-glass. These bubbles will tend to be trapped in the air vent cavity on top of the air separator. They can be released by removing the cap and depressing the pin on the (car tire like) valve. Always remember to replace the valve cap.

Venting of this type should be done at each pre-trip.

As the glycol becomes colder it becomes denser and more viscous and the entrapped air bubbles will tend to reduce in size. As the glycol temperature falls, the bubbles will come out of suspension and have a tendency to collect and combine into one larger bubble. This will tend to happen normally at the highest point in the pipe run or place where the pipe size changes and causes a pressure drop. Once the large bubble begins it will tend to accumulate more of the air in the system. When the volume of the air bubble exceeds the cross section of the pipe, it will tend to act as plug slowing the flow of liquid to the suction side of the pump and stall the pump - resulting in no flow of liquid. Obviously, this large bubble cannot be seen from the outside of the system and the small bubbles seen in the sight glass may give the impression of liquid flow. The refrigeration unit will give the impression of working but the cargo temperature will rise. If this happens, there may be a frost build up on the expansion valve at the chiller. To free the system of the residual bubbles the temperature of the glycol may have to be increased. Because of the comparative large mass of the cargo compared to the mass of the glycol of a loaded container it may be possible to lift the temperature of the glycol without affecting the cargo temperature. If this is done, vent the air trap frequently. On completion, do not forget to replace the valve cap.

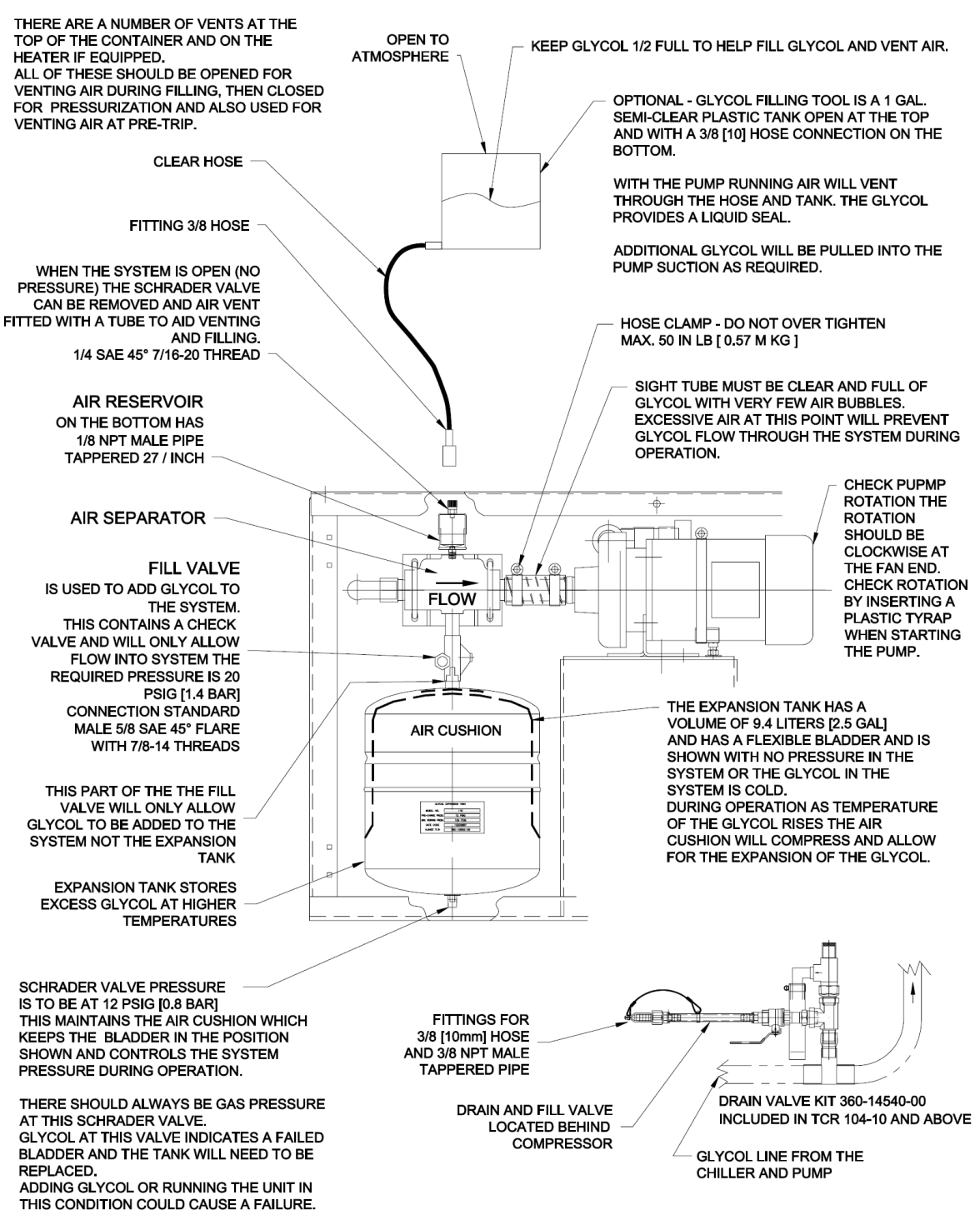

**COMPONENTS OF THE
GLYCOL SYSTEM
FOR ADDING GLYCOL AND VENT AIR
MODEL TCR-104**

PR-2089-04 REV 1-17-2007

GLYCOL CHARGING STEPS CHECK LIST (see detail on the preceding page)

INITIAL FILL

- 1 – Begin with the system open (no pressure).
- 2 – Open all vents slightly and begin adding glycol at the lowest point. The air will escape as the glycol fills. Closing each vent as the glycol fills to that valve.
- 3 – When the unit has been filled with glycol close the valves.
- 4 – At the fill / drain 1/4 turn valve back of the compressor (360-14640-00 kit for older units) continue adding approximately 4.5 liter (1.2 gal) additional glycol with pressure of 1.4 Bar (20 psi).
Or
If the fill valve above the expansion tank is used, pressure of 1.4 bar [20 psi] will be needed to push the open the internal valve and push the glycol into the system.
Note: the glycol will only flow into the system using this valve.
- 5 – Turn the unit on and adjust the set point to the same as the cargo temperature shown on the display (run only the pump). There will most likely be air trapped in the container piping, continue venting at the plugs or valves on the container piping with the pump running (this may take some time) to clear the pockets of trapped air tank pipe work.
- 6 – Check the clear sight tube on the pump inlet there should only be very small bubbles of air.
- 7 - Check all the plugs and valves for leaks.
- 8 – Set the thermostat to a lower temperature and check for cooling and vent the small reservoir on top of the expansion tank to remove acuminated air. As the tank cools it may be possible to add more glycol.
- 9 – After the system sets idle overnight, we suggest it be checked to remove air that may have move to the vent points. Check all the plugs and valves for leaks and pump sight tube for air no bubbles.

ADDING GLYCOL TO A CLOSED SYSTEM

- 1 – There is a fill / drain hose and a 1/4 turn valve back of the compressor that can be used to add glycol under pressure (see detail). Note the pressure relief valve set to 3.5 Bar (50 psi). Take care not to add air into the system; the valve can be slightly opened to fill the hose with glycol before making the connection. If all the air has not been removed from the system, it may prevent the addition of glycol.
- 2 – Glycol could also be added at any of the vent valves.
- 3 – Also the fill valve above the expansion tank can be used to add glycol with pressure of 1.4 Bar (20 psi). This fill valve has a check valve and will prevent glycol from flowing out. Note the fill valve will close when the bladder begins to be compressed.

5.10 PTI Form

It is important that a Pre-Trip Inspection (PTI) be completed prior to each shipment.

The TCR-104 PTI form can be found on Klinge's website at: <http://www.klingecorp.com/pti/>.

6.0 SERVICING COMPONENTS

6.1 Compressor

6.1.1 Compressor Motor Protection

The compressor motor of the TCR-104 is equipped with an internal overload device. This device will break the star-point and stop the compressor if a problem arises which causes the motor to overheat. When the motor cools sufficiently, the overload will reset automatically.

6.1.2 Compressor Lubrication

The compressor used in the TCR-104 is equipped with an oil pump and will operate in either direction of rotation. In order to check the oil level in the compressor, a sight glass is provided in the front of the shell, allowing the oil inside the crankcase to be visible at all times.

Since the oil level will vary with operating conditions, it should be checked only after the compressor has been running long enough for the crankcase to warm up to operating conditions. The level will be maintained at 1/2 minimum to 2/3 maximum of the sight glass while running. If the level is low, oil should be added.

6.1.3 Adding Oil

Caution:

This unit is charged with R-404A or R-452A refrigerant. Therefore, mineral oil lubricant cannot be used.

The only oil approved by the compressor manufacturer is Polyester lubricant, "Mobil EAL Arctic 22 CC" (Approximate Charge 4.7L (5 qt)).

If the compressor is not evacuated or charged, oil may be added through a crankcase port by pouring.

If the compressor is charged and the system can be run, oil should be added through the suction service valve as follows:

- a. Back seat compressor suction service valve. Connect manifold gauge to suction service valve port and start unit. Front seat suction service valve partially until a suction pressure of approximately 0.1 bar is maintained.
- b. With a can of oil opened, measured, and ready, carefully open the manifold suction gauge valve until a positive pressure can be felt at the outlet of the center charging hose.
- c. Now place the end of the charging hose into the can of oil and control the bubbling with the manifold valve. Continue to front seat the suction valve to produce a mild vacuum (10" vacuum) and use the vacuum to pull the oil into the crankcase. By opening the manifold valve a little more, the oil can be sucked into the crankcase faster.
- d. As soon as enough oil has been transferred to the compressor, shut off the manifold valve. If the can being used is almost empty, be careful that air is not sucked in with the oil.

e. Back seat compressor suction service valve. Remove gauge, manifold hoses, and replace caps securely. Allow the unit to run 30 minutes before rechecking the oil level in the compressor sight glass. Check the oil immediately after the compressor has been shut off.

Note:

Always keep commercial oil stored in sealed containers. Oil exposed to the atmosphere will absorb moisture, which can cause trouble when introduced into the system. Use only the grades of oil, which are suitable and recommended for compressor lubrication and have been specially processed so as to have the necessary low moisture content.

6.1.4 Compressor Motor Burnout

Caution:

Acids are formed during a motor burnout. Use rubber gloves and eye protection when working on the system or handling contaminated parts.

When a hermetic motor burnout occurs, the stator winding insulation decomposes forming carbon, water, and acid. To prevent contamination of the refrigerant system and repeat motor failures, definite steps **MUST** be taken to ensure that the refrigerant circuit is kept clean from contamination.

Damage to a compressor caused by failure to clean the system properly after burnout constitutes abuse and is not covered by the terms of the warranty.

After it has been observed that a hermetic motor has failed, either by observing an obvious electrical fault or by a strong burnt odor to the refrigerant gas released at the discharge valve port, the following procedure must be followed to clean the system and thus prevent failure of a replacement compressor.

6.1.5 System Cleaning Procedure after Hermetic Motor Burnout

Flushing out a refrigeration system with R-11 should not be considered since scientific evidence has linked ozone depletion to R-11 emissions. In case of a motor burnout, Copeland recommends the filter drier cleaning procedure. Basically, this involves the use of approved filter dryers incorporated with an adequate desiccant (not a filter only) in both the liquid and suction lines.

If there is no suction line filter and it is difficult to install a suction line filter, it is permissible to just use a liquid line filter. However, in step 9, instead of removing the suction line filter drier, inspect the compressor suction strainer and clean if necessary.

The filter-drier procedure has proven to be very economical, especially when the refrigerant in the system is recovered using safe recovery techniques. This can be easily accomplished if the compressor is fitted with service valves.

1. Recover refrigerant from the system. Remove the inoperative compressor and install the replacement.
2. Since the normal color of refrigerant oil varies from oil to oil, take a sample of oil from the replacement compressor and seal in a small glass bottle for comparison purposes after the cleaning operation is complete. Suitable two-ounce bottles are obtainable at any drug store.

3. Inspect all system controls such as expansion valve and solenoid valve. Clean or replace if necessary. Remove or replace any filter driers previously installed in the system, and clean or replace any filters or strainers.
4. Install the recommended size remote filter drier in the suction line and an oversized filter drier in the liquid line.
5. Evacuate the system.
6. Charge through the remote filter drier with the refrigerant which was removed and recovered. Add additional refrigerant as necessary.
7. Start the compressor and put the system in operation. After (4) hours, stop the unit and replace the filter driers.

After the completion of step 7, allow the unit to operate for 48 hours. Check the odor (**warning: smell cautiously**) and compare the color of the oil with the sample taken in Step 2. If an acid test kit is available, test for acid content. If the oil is discolored and smells acidic, or if the moisture indicator indicates a high moisture content in the system, change the filter driers. The compressor oil can be changed if considered desirable. Allow the system to operate for an additional 48 hours and recheck as before. Repeat until the oil remains clean, odor free and the color approaches that of the original sample.

Replace the liquid line filter drier with one of the normally recommended size. Remove the suction line filter drier.

After the cleaning procedure is completed, recheck in approximately two weeks to ensure that the system condition and operation is completely satisfactory.

6.2 Condenser Fan Motor

This totally enclosed motor is equipped with shielded ball bearings, which require no lubrication. The motor is designed to operate satisfactorily with line voltages, which are within 10% of nameplate values. The motor is protected by an automatic reset klixon, which is normally closed. In case of overheating, the klixon will open and the motor will stop.

CAUTION:

Replacement fan motors may be manufactured for opposite rotation from what is required. Always check for proper rotation and, if required, reverse 2 leads.

6.3 Condenser Fan

If a motor fan must be removed from the motor shaft for any reason, be sure that the fan dimensions for relocating the fan are used in accordance with the fan-positioning sketch.

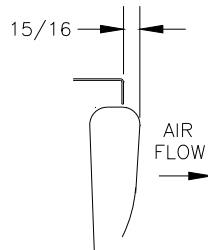

Condenser Fan Position

Install assembly in the unit, but do not tighten the cap screws holding the motor to the motor mount. Extreme care **must** be taken to align the fan wheel and the inlet ring to be concentric and to have the fan blade extend 15/16 of an inch into the air discharge side of the inlet ring.

6.4 Filter Drier Replacement

To replace a drier:

1. "Back-seat" the compressor suction service valve and attach refrigerant recovery line to the suction valve service port. Front seat valve 1½ turns so pressure can be read. The recovery line should come from a manifold gauge since the line will also be used to evacuate the system and perhaps add refrigerant.
2. Close the liquid line shutoff valve. Using the unit's compressor, pump down the system until the suction pressure stabilizes between 0 and 1.5 psig (0.1 bar). Remove all power to the unit, then front seat the suction service valve.
3. Recover any refrigerant that may be in the system from the hand valve to the compressor suction service valve. Then remove drier.
4. Remove caps from new drier and install immediately. Pump down the piping from the hand valve to the compressor suction service valve using a vacuum pump.
5. Back seat suction service valve and open liquid line hand valve. Run unit for fifteen minutes and check refrigerant level. If necessary, add refrigerant until ball in bottom sight glass is floating. Back seat compressor suction service valve and remove refrigerant recovery line. Put cap on suction valve service port.

6.5 High Pressure Switch

The high-pressure switch functions automatically to open or close the compressor contactor coil circuit upon increase or decrease in discharge pressure.

To replace a pressure switch:

1. With the motor turned off, back seat compressor suction and discharge service valves and attach refrigerant recovery lines to the service ports of both valves. Front seat suction service valve 1½ turns

so suction pressure can be read. The recovery lines should come from a manifold gauge since the line will also be used to evacuate the system and perhaps add refrigerant.

2. Close the liquid line hand valve. Start the unit and pump down the system until the suction pressure stabilizes between 1 and 1.5 psig (0.1 bar). Then **turn unit off** and front seat the compressor service discharge valve.
3. Recover any refrigerant that may be in the system from the liquid line hand valve to the compressor discharge service valve. Then change pressure switch.
4. Pump down the compressor and piping using a vacuum pump.
5. Back seat compressor discharge-valve and open liquid line hand valve. Run unit for fifteen minutes and check refrigerant level. If necessary, add refrigerant until ball in bottom sight glass is floating. Back seat compressor suction service valve and remove refrigerant recovery lines. Put cap on suction valve service port.
6. Reconnect wires with splice connectors.

6.6 Thermal Expansion Valve

6.6.1 General

The thermal expansion valve automatically maintains superheat of the refrigerant gas leaving the evaporator coil. The only maintenance that the valve may require is to check that the bulb is making good contact with the suction line. The thermal bulb is secured to a pre-selected point on the suction line positioned at 4 or 8 o'clock, by a perforated metal strap. If, for any reason, these bulbs are removed from the suction line, care **MUST** be taken to be sure that the bulbs are correctly replaced and insulated. The no-drip tape insulating the bulb should be sealed to prevent surrounding air from contacting bulb.

Note:

If the body must be changed for any reason, it is not necessary to disassemble the new tx-valve but use extreme care to prevent warping of the new valve body due to excess heat being applied during brazing. To prevent warping, it is necessary to use wet rags to reduce heat buildup of the valve body. Direct torch tip away from the body of the valve. Maximum heat that can be applied is 100°C (212°F) for the element, and 150°C (302°F) for the body.

6.6.2 Replacement of Defective Thermostatic Element

The only part of the thermostatic expansion valve that might fail is the power element. The power element can be easily changed.

1. Before removing the power element, the refrigerant must be removed from the evaporator coil and associated piping. To do this follow the steps under drier replacement.
2. Remove the power element bulb from the suction line and unscrew the power element. When removing the element check to be sure the push rods are in place and have not fallen out.

3. Install the new element hand tight. After hand tight, turn element clockwise 60° (movement equal to one hex flat).

6.6.3 Expansion valve adjustment

The expansion valve is set and tested at the factory before shipping. When the application or operating conditions require a different setting, the valve may be adjusted to obtain the required operating superheat. The expansion valve adjustment is capped for protection.

Remove the protective cap. To reduce the superheat, turn the adjustment stem counterclockwise or to the left. To increase, turn the adjustment stem clockwise or to the right.

Only make one full turn at a time, it may take approx. 30 minutes after each adjustment before a new balance can be acquired.

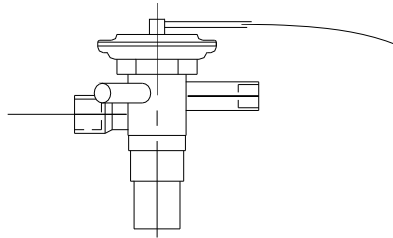

Note: Refer to the temp. / pressure chart when calculating the superheat.

1. Measure the temperature of suction line at the point the bulb is clamped.
2. Obtain the suction pressure that exists in the suction line at the bulb by either of the following methods.
 - A. If the valve is externally equalized, a gauge in the external equalizer line will indicate the desired pressure directly and accurately.
 - B. Read the gauge at the suction valve of the compressor. To the pressure add the estimated pressure drop through the suction line between bulb location and compressor suction valve. The sum of the gauge reading, and the estimated pressure drop will equal the approximate suction line pressure at the bulb.
3. Convert the pressure obtained in 2A and 2B to saturated evaporator by using the Temperature / Pressure chart located in this manual before the service parts section.
4. Subtract the two temperatures obtained in 1 and 3 – the difference is the superheat.

What's your Superheat?

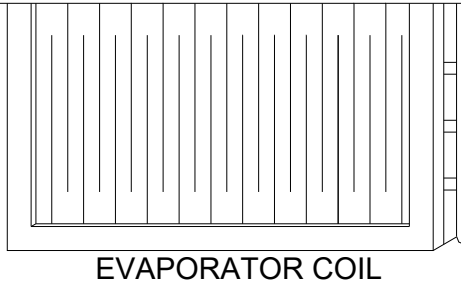

EXAMPLE

REFRIGERANT

— 22 —

TEMPERATURE

HERE

READS

52°

40°

12°

SUPERHEAT

A. TO THE SUCTION PRESSURE
at compressor

66 PSIG

2 PSI

B. ADD ESTIMATED SUCTION LOSS

68 PSIG

C. TO OBTAIN SUCTION PRESSURE
at bulb

CONVERTED TO TEMP.

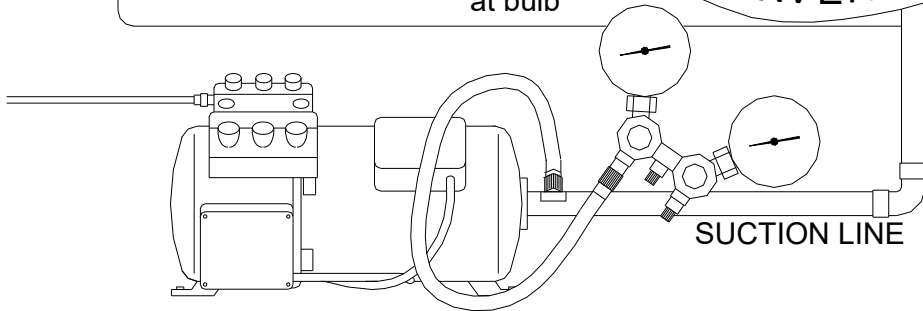

7.0 TROUBLE SHOOTING

7.1 General Information

Several components are incorporated into the unit to assist the serviceman in finding the cause of problems concerning the operation and efficiency of the unit.

The thermostat cycle being called for is indicated by the LED display. These lights should be used in conjunction with the pressure gauges to determine if certain cycles are operating.

7.2 Service Components

Sight glasses are mounted in the liquid receiver to determine if the refrigerant charge is correct. Check the container at 0°C (32°F) container temperature. The ball in the bottom sight glass should be floating.

The sight glass moisture indicator mounted in the liquid line will show if the refrigerant system is dry or wet. If it is green in color, the system is dry. If it is yellow in color, the system is wet.

7.3 Microprocessor Thermostat

The microprocessor thermostat will indicate faults during the function test mode. During normal cooling faults are indicated by LED's marked alarm, probe failure and temperature failure.

Alarm indicators are reset when power is removed from the thermostat.

During the function test, LED's on the thermostat steps 1 through 5 will indicate a fault within the thermostat **only**.

The service technician will need to listen for each function to occur.

The thermostat output relays each have a small red LED located at their base and visible only from the side of the thermostat. When an LED is lit, the corresponding output relay is energized. Do not confuse these LEDs with the indicator LEDs on the edge of the thermostat.

LED INDICATORS on edge of Thermostat

A) IN OPERATION:

Alarm LED ON and Temp Failure LED Flashes

Temperature change-rate too slow ($\pm 0.1^{\circ}\text{F}/\text{Hr}$). Function locked within $\pm 3.6^{\circ}\text{F}$ of set point.

Alarm LED ON and Temp Failure LED Flashes

Temp varies more than 3.6°F from set point for more than 120 minutes, after reaching set point.

Alarm LED ON and Cargo LED ON

Cargo probe open or shorted.

Alarm LED ON and Glycol LED ON

Glycol probe open or shorted

B) DURING FUNCTION TEST:

All LED's Flash

Start of function test.

Any LED Flashing

Failure of the function as indicated in 4.5.3.

7.4 Trouble Shooting Chart

The following trouble shooting chart is by no means complete but covers the more general type of problems, which may occur if a breakdown is experienced.

PROBLEMS:

POSSIBLE CAUSE

CORRECTIVE ACTION SUGGESTED

Power to unit, but unit will not start

Tripped CB1, CB2 or CB3

Reset

No control circuit voltage at T1

Check primary side for 480V @ T1
Check for proper connections at T1
Replace T1 if defective

No control circuit voltage at Term
X3 & G (12V), Term T1 & G (24V)

Faulty SW1, Switch. Replace SW1

Thermostat will not function test

No Voltage (12V) between Term
27 & 32 when SW2 is depressed

Faulty SW2. Replace SW2

Compressor will not run

Compressor contactor "C" coil faulty
or mechanical failure of contactor

Replace contactor

High Pressure Switch (HPS) open
Discharge pressure too high

Remedy reason for high discharge pressure

Defective HPS

Replace

Open compressor windings due to
thermal protection switch being open

Remedy cause of overheating

Open Compressor windings when compressor is cool Replace compressor

Compressor trips CB1 but does not run due to mechanical restriction Replace compressor

Glycol pump does not run

Faulty phase sensor "PS" Replace

"PC1" or "PC2" phase changing contactor faulty Replace contactor

Condenser fan and glycol pump do not run

See — Glycol Pump Does Not Run -----

Condenser fan only will not run

"CF" Condenser fan contactor faulty Replace

Motor internal overload protection open or motor windings open Replace motor

Glycol pump & condenser fan run backwards

Phase Sensor "PS" faulty. Does not change phase. Check with test button. Replace "PS"

Circuits 6 & 8 from PS to PC1 & PC2 cross wired Correct wiring

Cargo temperature too high

Supply glycol probe circuit open Check wiring. Replace probe

Faulty thermostat Replace

Cargo temperature too low

Glycol supply probe circuit shorted Check wiring

Faulty thermostat Replace

Cooling capacity problem

Refrigerant level too low Check & add refrigerant if required

Partially or completely blocked filter drier Check & replace

Glycol pump not running or running in wrong direction.

Check & correct

Faulty TXV

Replace

Cooling capacity problem

Severe lube oil overcharge

Remove excess oil. Check oil level (allow oil level to be within sight glass when compressor is hot and has been running for 10 to 15 minutes).

Compressor mechanical problem reducing pumping capacity

Replace defective compressor

UNIT ELECTRICAL INFORMATION (Amps at 480 Volt 60Hz)

Input	3 ph / 480V $\pm 10\%$ / 60 Hz $\pm 2.5\%$
Compressor full load at 25 psig (1.7 bar) suction and 375 psig (26 bar) discharge	9 amps
Condenser fan motor 1.49 kW 1725 RPM	3.0 amps
Glycol pump motor 1.1 kW 3450 RPM	2.5 amps
Full load current	14 amps
Total start current	60 amps

TEMPERATURE-PRESSURE CHART

For use when converting pressure to temperature when calculating the superheat.

R-12 added for reference only.

DEGREES FAHRENHEIT	DEGREES CENTIGRADE	R-12 PSIG	R-22 PSIG	R-502 PSIG	R-134A PSIG	R-404A (HP-62) PSIG
-50	-45.6	15.4	6.2	0.2	18.4	0
-48	-44.4	14.6	4.8	0.7	17.7	0.8
-46	-43.3	13.8	3.4	1.5	17	1.6
-44	-42.2	12.9	2	2.3	16.2	2.5
-42	-41.1	11.9	0.5	3.2	15.4	3.4
-40	-40.0	11	0.5	4.1	14.5	5.5
-38	-38.9	10	1.3	5	13.7	6.5
-36	-37.8	8.9	2.2	6	12.8	7.5
-34	-36.7	7.8	3	7	11.8	8.6
-32	-35.6	6.7	4	8.1	10.8	9.7
-30	-34.4	5.5	4.9	9.2	9.7	10.8
-28	-33.3	4.3	5.9	10.3	8.6	12
-26	-32.2	3	6.9	11.5	7.7	13.2
-24	-31.1	1.6	7.9	12.7	6.2	14.5
-22	-30.0	0.3	9	14	4.9	15.8
-20	-28.9	0.6	10.1	15.3	3.6	17.1
-18	-27.8	1.3	11.3	16.7	2.3	18.5
-16	-26.7	2.1	12.5	18.1	0.8	20
-14	-25.6	2.8	13.8	19.5	0.3	21.5
-12	-24.4	3.7	15.1	21	1.1	23
-10	-23.3	4.5	16.5	22.6	1.9	24.6
-8	-22.2	5.4	17.9	24.2	2.8	26.3
-6	-21.1	6.3	19.3	25.8	3.6	28
-4	-20.0	7.2	20.8	27.5	4.5	29.8
-2	-18.9	8.2	22.4	29.3	5.5	31.6
0	-17.8	9.2	24	31.1	6.5	33.5
2	-16.7	10.2	25.6	32.9	7.5	34.8
4	-15.6	11.2	27.3	34.9	8.5	37.4
6	-14.4	12.3	29.1	36.9	9.6	39.4
8	-13.3	13.5	30.9	38.9	10.8	41.6
10	-12.2	14.6	32.8	41	12	43.7
12	-11.1	15.8	34.7	43.2	13.1	46
14	-10.0	17.1	36.7	45.4	14.4	48.3
16	-8.9	18.4	38.7	47.7	15.7	50.7
18	-7.8	19.7	40.9	50	17	53.1
20	-6.7	21	43	52.5	18.4	55.6
22	-5.6	22.4	45.3	54.9	19.9	58.2
24	-4.4	23.9	47.6	57.5	21.4	60.9
26	-3.3	25.4	49.9	60.1	22.9	63.6
28	-2.2	26.9	52.4	62.8	24.5	66.5
30	-1.1	28.5	54.9	65.6	26.1	69.4
32	0.0	30.1	57.5	68.4	27.8	72.3
34	1.1	31.7	60.1	71.3	29.5	75.4
36	2.2	33.4	62.8	74.3	31.3	78.5
38	3.3	35.2	65.6	77.4	33.2	81.8
40	4.4	36.9	68.4	80.5	35.1	85.1
42	5.6	38.8	71.3	83.8	37	88.5
44	6.7	40.7	74.5	87	39.1	91.9
46	7.8	42.7	77.6	90.4	41.1	95.5
48	8.9	44.7	80.7	93.9	43.3	99.2
50	10.0	46.7	84	97.4	45.5	102.9

DEGREES FAHRENHEIT	DEGREES CENTIGRADE	R-12 PSIG	R-22 PSIG	R-502 PSIG	R-134A PSIG	R-404A (HP-62) PSIG
52	11.1	48.8	87.3	101	47.7	109
54	12.2	51	90.8	104.8	50.1	113
56	13.3	53.2	94.3	108.6	52.3	117
58	14.4	55.4	97.9	112.4	55	121
60	15.6	57.7	101.6	116.4	57.5	125
62	16.7	60.1	105.4	120.4	60.1	130
64	17.8	62.5	109.3	124.6	62.7	134
66	18.9	65	113.2	128.8	65.5	139
72	22.2	72.9	125.7	142.2	74.2	153
74	23.3	75.6	130	146.8	77.2	158
76	24.4	78.4	134.5	151.5	80.3	164
78	25.6	81.3	139	156.3	83.5	169
80	26.7	84.2	143.6	161.2	86.8	174
82	27.8	87.2	148.4	166.2	90.2	180
84	28.9	90.2	153.2	171.4	93.6	185
86	30.0	93.3	158.2	176.6	97.1	191
88	31.1	96.5	163.2	181.9	100.7	197
90	32.2	99.8	168.4	187.4	104.4	203
92	33.3	103.1	173.7	192.9	108.2	209.9
94	34.4	106.5	179.1	198.6	112.1	215
96	35.6	110	184.6	204.3	116.1	222
98	36.7	113.5	190.2	210.2	120.1	229
100	37.8	117.2	195.9	216.2	124.3	235
102	38.9	120.9	201.8	222.3	128.5	242
104	40.0	124.7	207.7	228.5	132.9	249
106	41.1	128.5	213.8	234.9	137.3	256
108	42.2	132.4	220	241.3	142.8	264
110	43.3	136.4	226.4	247.9	146.5	271
112	44.4	140.5	232.8	254.6	151.3	279
114	45.6	144.7	239.4	261.5	156.1	286
116	46.7	148.9	246.1	268.4	161.1	294
118	47.8	153.2	252.9	275.5	166.1	302
120	48.9	157.7	259.9	282.7	171.3	311
122	50.0	162.2	267	290.1	176.6	319
124	51.1	166.7	274.3	297.6	182	328
126	52.2	171.4	281.6	305.2	187.5	336
128	53.3	176.2	289.1	312.9	193.1	345
130	54.4	181	296.8	320.8	198.9	354
132	55.6	185.9	304.6	328.9	204.7	364
134	56.7	191	312.5	337.1	210.7	373
136	57.8	196.1	320.6	345.4	216.8	383
138	58.9	201.3	328.9	353.9	223	392
140	60.0	206.6	337.3	362.6	229.4	402
142	61.1	212	345.8	371.4	235.8	413
144	62.2	217.5	354.5	380.4	242.4	423
146	63.3	223.1	363.3	389.5	249.2	434
148	64.4	228.8	372.3	398.9	256	444
150	65.6	234.6	381.5	408.4	263	449

NOTE: THE USE OF ANY REFRIGERANT NOT SPECIFICALLY DESIGNATED BY THE MANUFACTURER MAY VOID THE WARRANTY.

8.0 SERVICE PARTS

- Section 8.1A Refrigeration Unit Parts
- Section 8.1B Refrigeration Unit Parts with Front Panel Removed
- Section 8.2A Refrigeration Unit Parts Rear
- Section 8.2B Refrigeration Unit Parts Rear, Wire Grill Removed
- Section 8.3A Electrical Box Parts Cover TCR-104-07, -10
- Section 8.3B Electrical Box Parts TCR-104-07, -10
- Section 8.3C Electrical Box Parts Outside TCR-104-07, -10
- Section 8.4A Optional Heater
- Section 8.4B Optional Heater Installation
- Section 8.4C Optional Heater Electrical Box Modification
- Section 8.5 Optional Remote Mounted Electrical Box TCR-104-08
- Section 8.6A Electrical Box Parts TCR-104-09
- Section 8.6B Electrical Box Parts TCR-104-09
- Section 8.6C Electrical Box Parts Cover TCR-104-09
- Spare Parts List TCR-104-07, -08, -09, -10

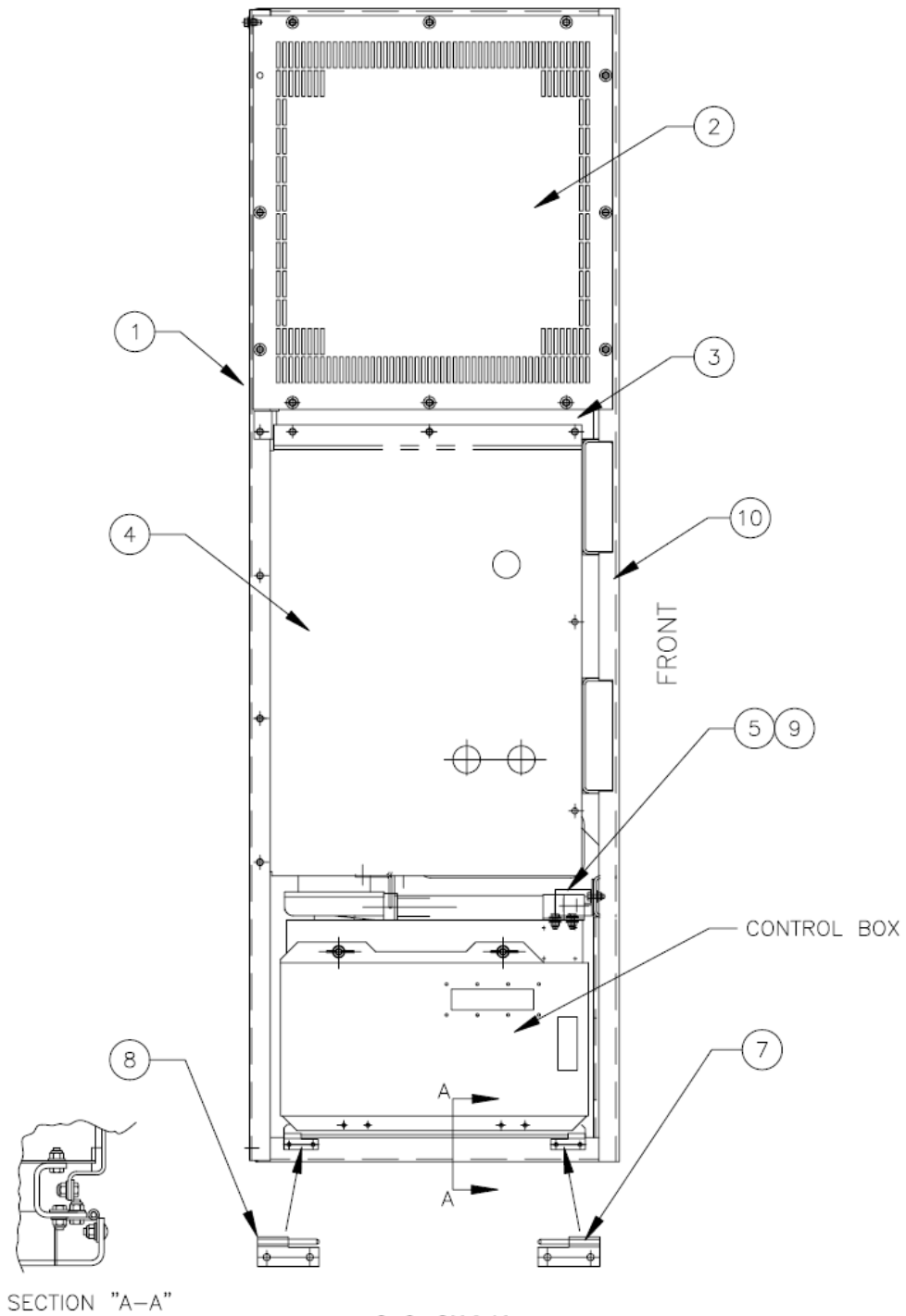

SECTION 8.1A**REFRIGERATION UNIT PARTS**

ITEM	PART NO.	DESCRIPTION	QTY.
1	360-12138-00	COVER TOP	1
2	060-15036-00	GRILL CONDENSER WHITE	1
3	360-12135-00	ANGLE HEADER ASSEMBLY	1
4	360-12134-10	PANEL FRONT ASSEMBLY TCR-104	1
5	K21-16315-00	FASTENER M12-1.75 SS ANTILUCE	1
6			
7	K29-17879-02	HINGE SLIP SS 9/32 HOLES WITH PIN	1
8	K29-17880-02	HINGE SLIP SS 9/32 HOLES WITH PIN	1
9	K28-10848-03	PLUG BUMPER .5 DIA x 1.25 LONG SYNTHETIC	2
10	360-15005-01	FRAME TCR-104 WHITE	1

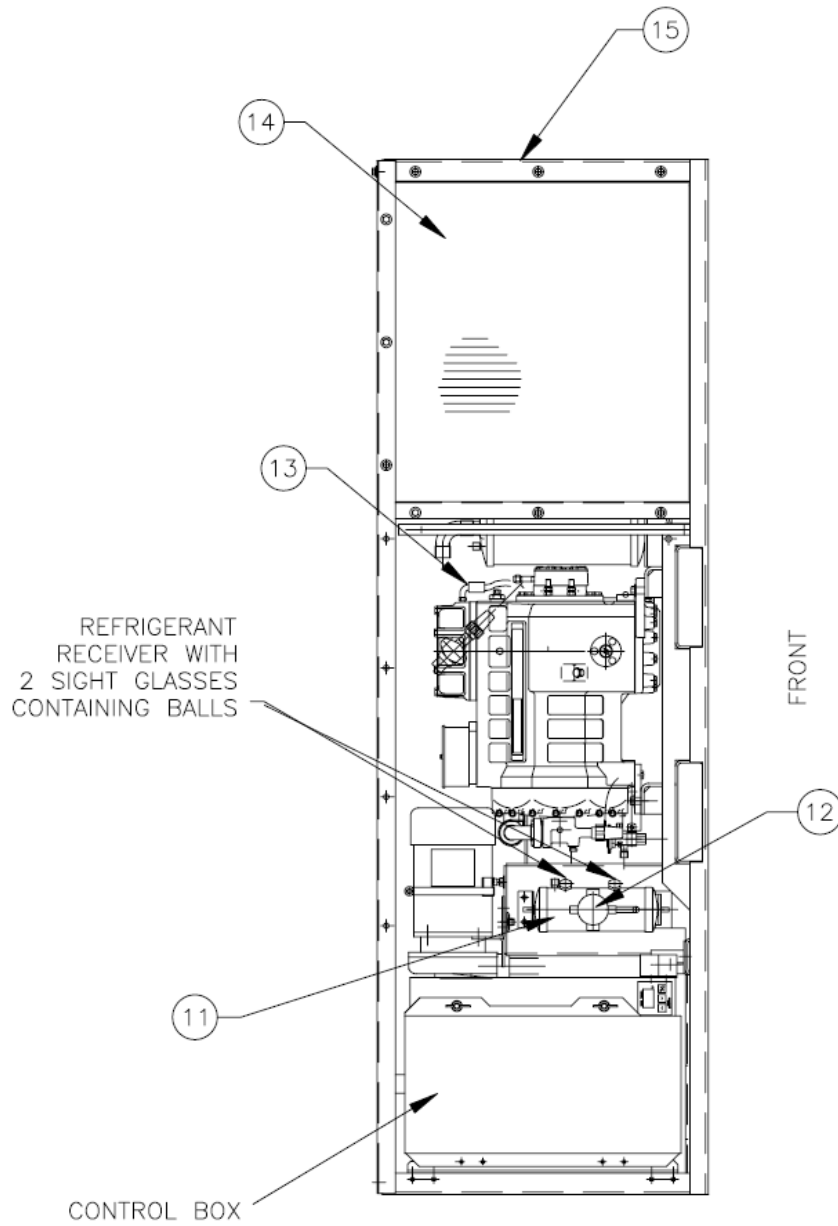

SECTION 8.1B
REFRIGERATION UNIT PARTS
FRONT WITH PANEL REMOVED

SECTION 8.1B REFRIGERATION UNIT PARTS – FRONT PANEL REMOVED

ITEM	PART NO.	DESCRIPTION	QTY.
11	360-10737-01	RECEIVER WITH VALVE TCR-104	1
12	K22-01672-0	VALVE HAND SHUT OFF 1/2	1
13	K25-26095-00	CONTROL HP NC OPEN 450 CLOSE 300	1
14	360-12137-00	ASSEMBLY COIL CONDENSER	1
15	K35-04602-00	LABEL CAUTION FAN STARTS AUTOMATICALLY	1

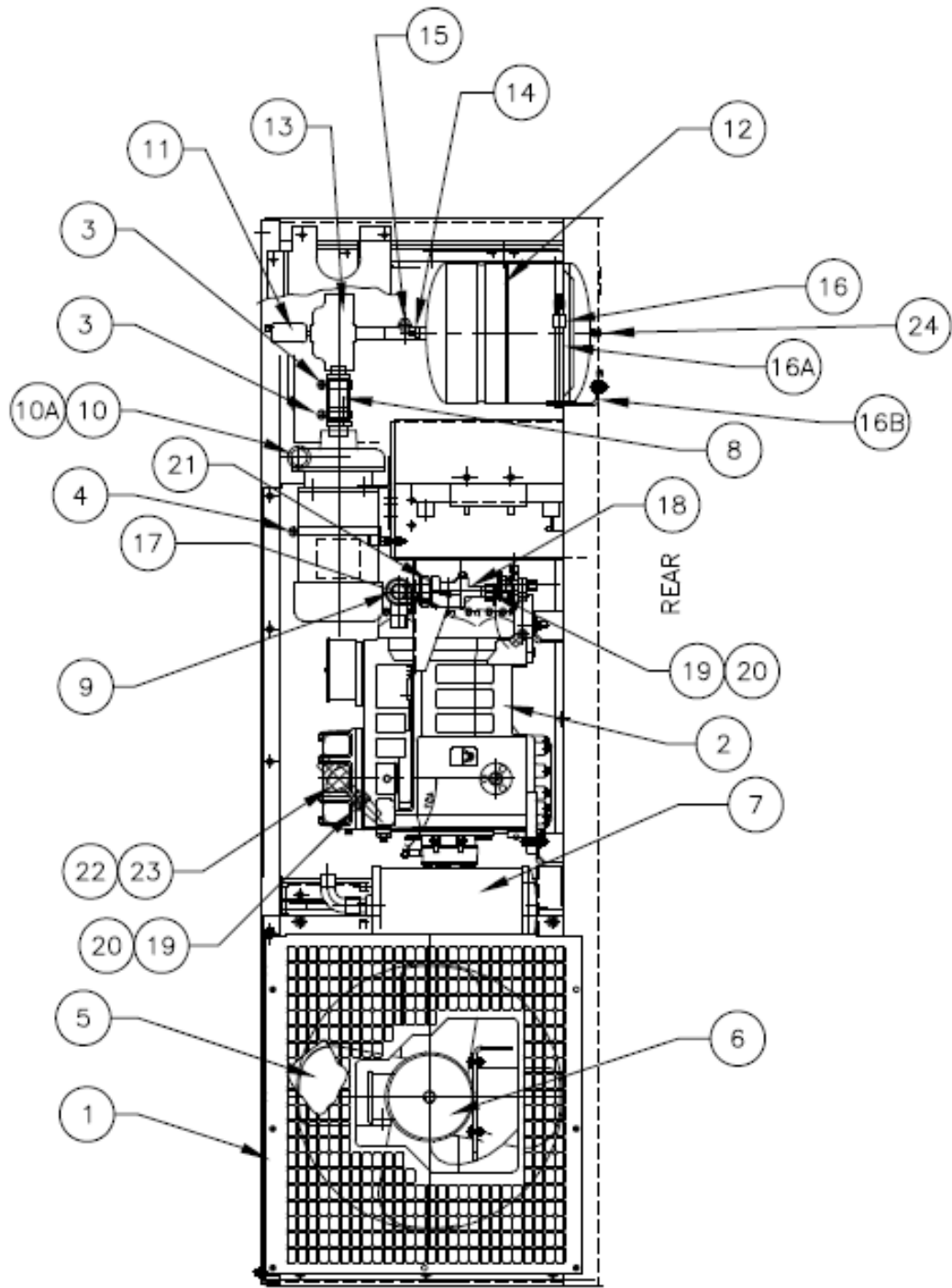

SECTION 8.2A
 REFRIGERATION UNIT PARTS
 REAR

SECTION 8.2A REFRIGERATION UNIT PARTS REAR

ITEM	PART NO.	DESCRIPTION	QTY.
1	060-14544-00	FAN GUARD TCR-104 WHITE	1
2A	K15-00019-01	COMPRESSOR 2 CYL SERVICE NO VALVES, R-404A	1
2B	K15-00019-02	COMPRESSOR 2 CYL SERVICE NO VALVES, R-452A	1
3	K21-16379-05	CLAMP CONSTANT TORQUE SS 1-1/16	2
4	K21-16379-16	CLAMP CONSTANT TORQUE SS 5-3/4	1
5	K26-24874-00	FAN 20.75 DIA 7/8 BORE 4 BLADE	1
6	K24-21158-00	MOTOR 2 HP 1800 RPM 230/460 3P	1
7	360-11798-00	HEAT EXCHANGER WITH LABEL	1
8	060-12592-01	TUBE PVC CLEAR WITH WIRE 1.5"IDx3	1
9	K22-06950-01	VALVE SUCTION PRESS REGULATOR 1-1/8SHRT	1
10	360-12208-03	PUMP MODIFICATION 1.5 HP	1
10A	K26-25035-00	KIT PUMP SEAL #11 EPDM	1
11	360-13469-00	RESERVOIR AIR 1/8 MPT 1/4 MFLR	1
12	360-12652-00	TANK EXPANSION WITH VALVE STEM	1
13	K26-24973-00	PURGER AIR 1" FPT PIT GUARD	1
14	K26-25044-00	VALVE FILL TROL & CHECK 1/2FPT	1
15	360-12191-00	CONNECTION GLYCOL CHARGING 5/8	1
16	360-12675-00	KIT EXPANSION TANK MOUNTING TCR-104	1
		(INCLUDES ITEMS 16A AND 16B)	
16A	360-12676-00	STRAP TANK MOUNTING	1
16B	360-12677-00	BRACKET BOTTOM SIDE MOUNT	3
17	K28-10889-00	GASKET DISCHARGE VALVE TO COMPRESSOR	1
18	K22-06914-00	VALVE COMPRESSOR SUCTION BRASS 1-1/8C 2H	1
		(INCLUDES ITEMS 19, 20 & 21)	
19	K22-06915-00	CAP VALVE SUCTION 1-1/16-18 UNF B	2
		(INCLUDES ITEM 20)	
20	K28-10891-00	SEAL VALVE CAP	2
21	K28-10890-00	GASKET SUCTION VALVE 2 HOLES 2	1
22	K22-06956-00	VALVE COMPRESSOR DISCHARGE BRASS 7/8 ODS	1
		(INCLUDES ITEMS 19 & 20)	
23	K28-10954-00	GASKET COMPRESSOR VALVE 2 HOLE	1
24	K22-06890-00	CAP VALVE STEM SS	1

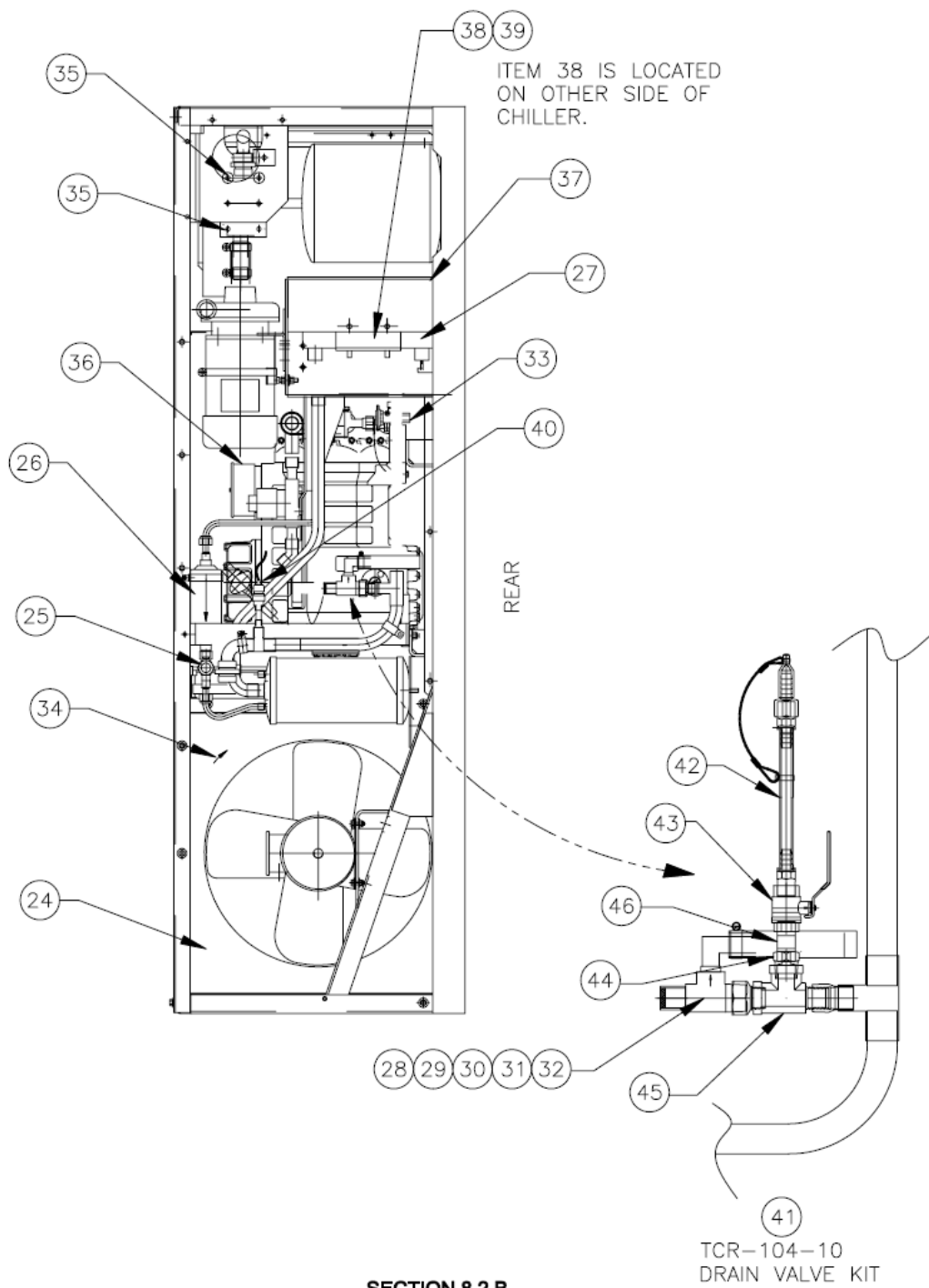

SECTION 8.2 B
REFRIGERATION UNIT PARTS
REAR WITH FAN GUARD ASSEMBLY REMOVED

SECTION 8.2B REFRIGERATION UNIT PARTS REAR – WIRE GRILL REMOVED

ITEM	PART NO.	DESCRIPTION	QTY.
24	060-15031-00	PLENUM CONDENSER FAN WELD WHITE	1
25	K26-22196-00	INDICATOR MOISTURE 1/2 MFL 1/2 FFL	1
26	K26-24906-00	FILTER/DRIER 1/2MFL HC WITH LABEL	1
27	K26-25025-00	CHILLER GLYCOL 5 TON	1
28	360-13460-00	VALVE RELIEF 50 PSI KIT 1/2MPT	1
		(INCLUDES ITEMS 29, 30, 31 &32)	
29	060-02709-00	TUBE KAZOO EPDM 1.5"X 9"LG	1
30	K28-10257-01	FITTING NYLON 90-3/4 X 1/2 MPT	1
31	K21-16247-00	CLAMP HOSE .50-1.25 SST	1
32	K22-06962-00	VALVE RELIEF 3/4 MPT 50-175PSI	1
33	K25-26203-00	VALVE TX 3/8	1
34	K35-05606-00	LABEL ARROW 1"X 2"	1
35	K21-16380-17	BOLT U SS 5/16-18x3"IS TY 304	2
36	K25-26129-03	CONNECTOR STRT PLASTIC SHORT 1/2 (NOT SHOWN)	1
37	K25-22382-01	CONDUIT PLASTIC SPLIT .35 ID .51 OD	2.5
38	360-12136-01	ANGLE CHILLER 3 INSERTS	1
39	360-12136-00	ASSEMBLY ANGLE CHILLER TCR 104	1
40	360-13807-00	KIT PROBE UNIVERSAL	1

41	360-14540 00	KIT DRAIN VALVE (ADDED ON -10 & LATER)	1
		(INCLUDES ITEMS 42, 43, 44, 45, & 46)	
42	360-14545-00	HOSE ASSEMBLY FOR 360-14540-00	1
43	K22-06933-02	VALVE BALL BRS 3/8 FPT 1/4 TURN	1
44	K23-13042-06	BUSH PIPE HEX BRS 1/2 MPT x 3/8	1
45	K23-13054-04	TEE STREET BRS 1/2 NPT	1
46	K23-13056-13	NIPPLE BRS 3/8 MPT x 1	1

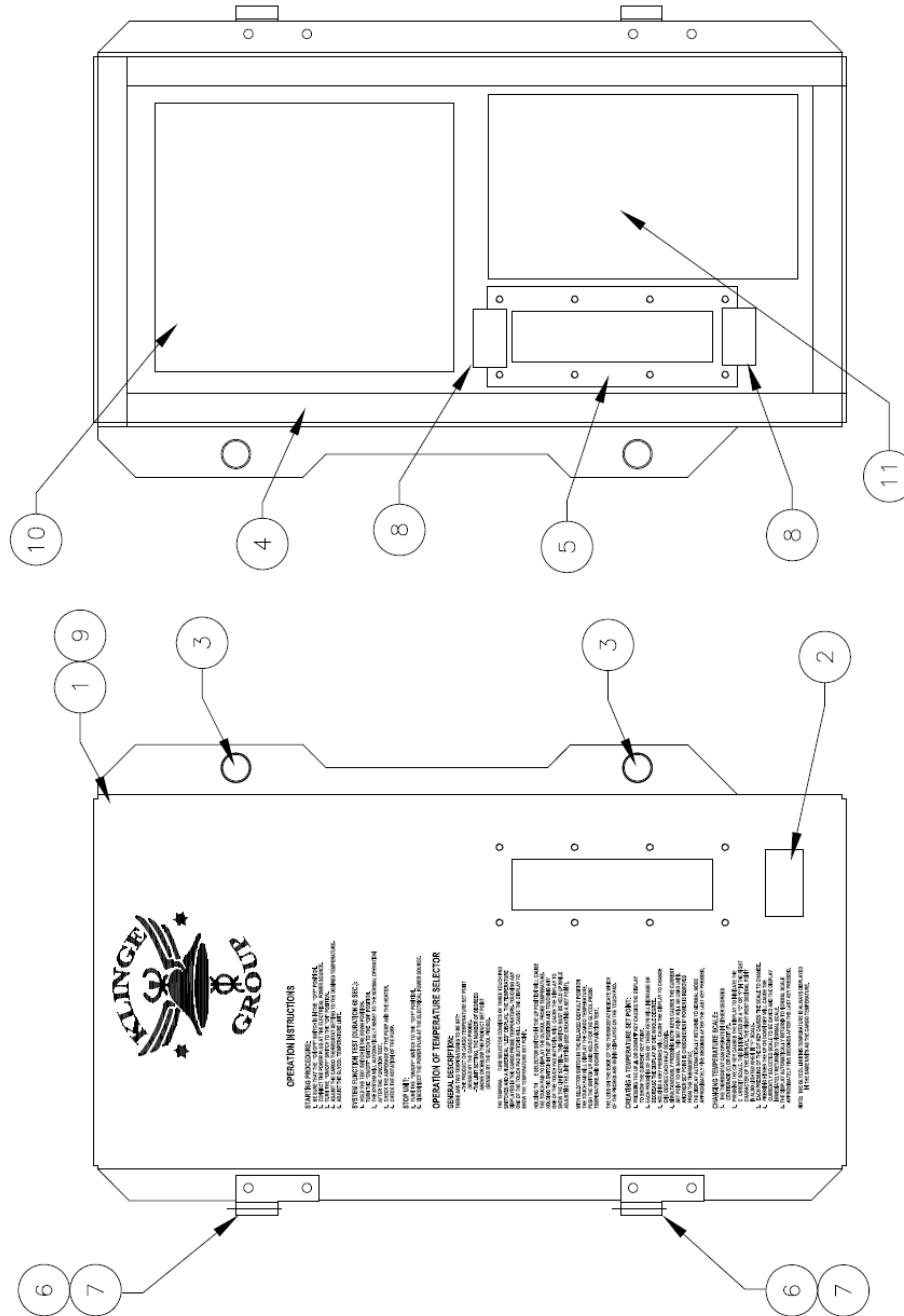

SECTION 8.3 A
ELECTRICAL BOX PARTS
COVER

SECTION 8.3A**ELECTRICAL BOX PARTS COVER**

ITEM	PART NO.	DESCRIPTION	QTY.
1	060-15024-03	DOOR ELECTRICAL BOX SILKSCREEN TCR-104	1
2	K35-05899-00	LABEL DANGER HIGH VOLTAGE 1.5x3	1
3	K28-10847-04	GROMMET INSERT .875 HOLE SIZE	2
4	K28-10813-00	STRIP SPONGE 3/8x7/8 SOFT CLOSED	6
5	K28-10945-00	WINDOW DOOR ELECTRICAL BOX	1
6	K29-17880-01	HINGE SLIP SS 9/32 HOLES SOCKET	2
7	060-09113-00	INSULATOR HINGE	2
8	060-12178-01	STRIP SPONGE 3/4 x 1 x 2	2
9	360-15140-07	DOOR ASSEMBLY TCR-104-07 DUAL (INCLUDES ITEMS 1 THRU 8, 10 & 11)	1
10	K35-05875-07	LABEL ELECTRICAL SCHEMATIC TCR-104-07	1
11	K35-05966-07	LABEL COMPONENT LAYOUT TCR-104-07	1

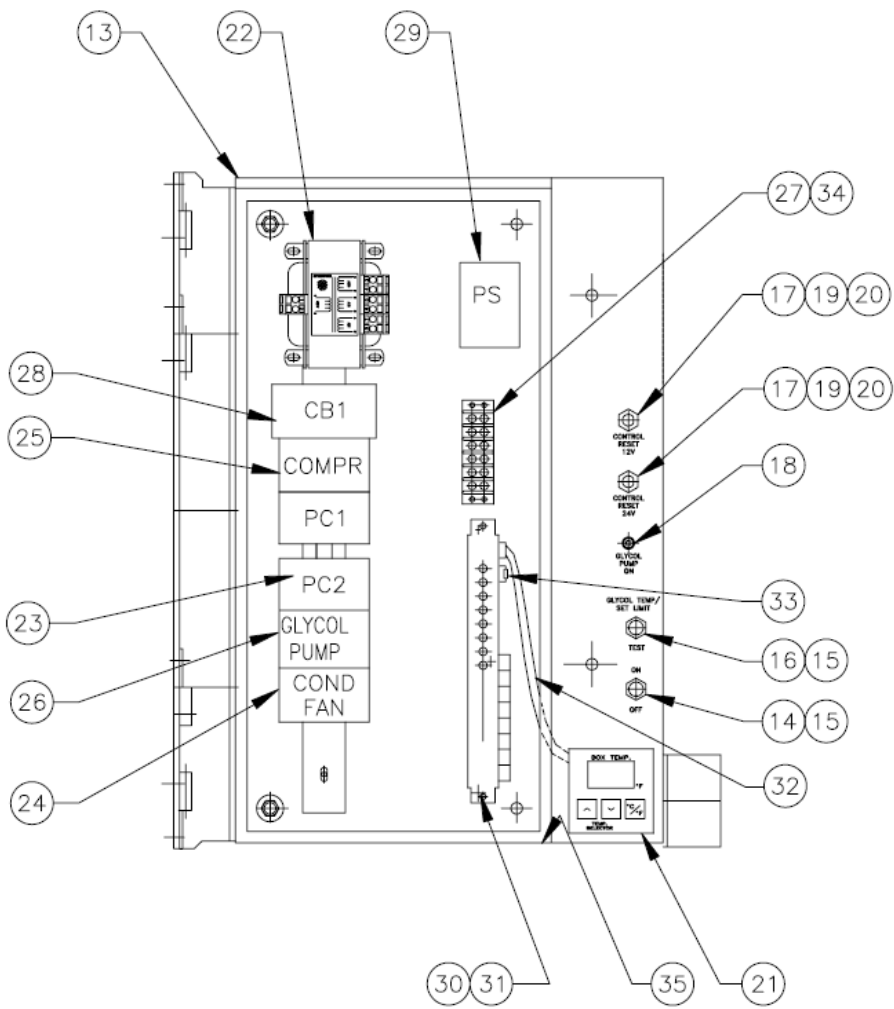

**SECTION 8.3 B
ELECTRICAL BOX PARTS**

SECTION 8.3B**ELECTRICAL BOX PARTS**

ITEM	PART NO.	DESCRIPTION	QTY.
12	360-15134-07	BOX ELECTRICAL TCR-104-07 COOL DUAL	1
13	060-15023-04	BOX ELECTRICAL SILKSCREEN TCR-104-04	1
14	K24-07458-00	SWITCH TOGGLE DPST ON-OFF (4) #6 SCREW	1
15	K24-17239-00	BOOT TOGGLE SWITCH	2
16	K24-22152-00	SWITCH TOGGLE SPDT MOM *ON-OFF-*ON #6	1
17	K24-22233-00	CIRCUIT BREAKER 4 A 2P 50/60HZ	2
18	K25-26330-00	LAMP INDICATOR CHROME YELLOW 24V	1
19	K28-10809-00	BOOT CIRCUIT BREAKER 15/32-32THD CLEAR	2
20	K28-10810-00	ADAPTER BOOT PUSH BUTTON THREADED	2
21	K31-00811-00	DISPLAY TEMPERATURE AND SELECTOR F/C	1
22	K25-26404-00	TRANSFORMER 180VA 460V 110/24/12 LAB	1
23	K24-22148-00	CONTACTOR REVERSING 9A 6P 24VAC 50	1
24	K24-22155-00	CONTACTOR 9A 3P 24/20 VAC 60/50 HZ	1
25	K24-22156-00	CONTACTOR 16A 3P 24VAC 50/60 Hz CO	1
26	K24-22268-00	OVERLOAD RELAY 1.8-2.8 AMP	1
27	K25-21619-06	BLOCK TERMINAL 6-32 6P	1
28	K24-22269-00	CIRCUIT BREAKER 16-20 AMP 3P	1
29	K31-00809-00	PHASE SENSOR 440V	1
30	360-10829-00	BASE THERMOSTAT	1
31	K25-26139-00	HOLDER CARD 4" GREEN (SET)	1
32	360-12540-01	CABLE RIBBON SHIELDED 18" 10 WIRES	1
33	360-14461-02	RESISTOR 10K OHM 1/4 WATT +-5% ASSEMBLY	1
34	K25-10444-00	JUMPER TERMINAL BLOCK #6 SCREW	1
35	K25-26134-00	BASE TYRAP MOUNTING BLACK ADHESIVE	1

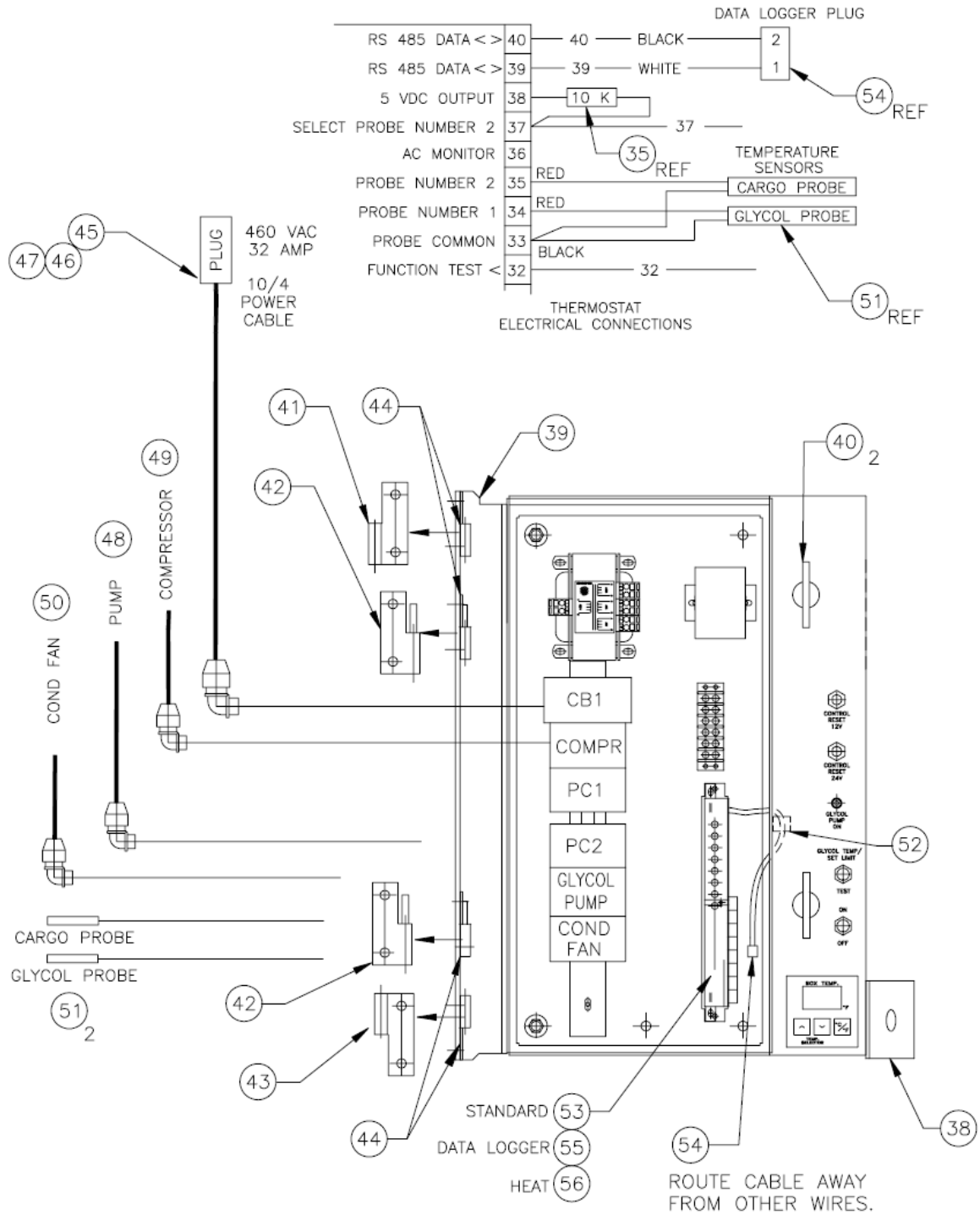

**SECTION 8.3 C
ELECTRICAL BOX PARTS
OUTSIDE**

SECTION 8.3C**ELECTRICAL BOX PARTS OUTSIDE**

ITEM	PART NO.	DESCRIPTION	QTY.
38	060-10820-00	RETAINER ELECTRICAL BOX SS PASS & POLISH	1
39	060-10748-00	BRACKET HINGE ELECTRICAL BOX	1
40	K21-16313-00	FASTENER BABY ANTILUSE M8x1.25	2
41	K29-17879-01	HINGE SLIP SS 9/32 HOLES SOCKET	1
42	K29-17879-02	HINGE SLIP SS 9/32 HOLES WITH PIN	2
43	K29-17880-01	HINGE SLIP SS 9/32 HOLES SOCKET	1
44	060-09113-00	INSULATOR HINGE	4
45	360-12133-00	CABLE MAIN POWER 460 VAC 55 FT	1
46	K25-20474-00	PLUG POWER 32A 380/440V 3P+G W	1
47	060-11114-01	CORD ELECTRICAL SO 10/4 CUT 55'LG	1
48	360-15049-00	CABLE ELECTRICAL BOX TO PUMP	1
49	360-15051-00	CABLE ELECTRICAL BOX TO COMPRESSOR	1
50	360-15052-00	CABLE ELECTRICAL BOX TO FAN MOTOR	1
51	360-13807-00	KIT UNIVERSAL PROBE	2
		(INCLUDES ITEMS 51A, 51B & 51C)	2
51A	K25-26097-00	PROBE TEMPERATURE .31 DIAx6"LGx 13 FT	2
51B	K25-26120-28	MARKER WIRE .25 ID CARGO	2
51C	K25-26120-29	MARKER WIRE .25 ID GLYCOL	2
52	360-13439-00	KIT TYRAP MOUNTING BASE	1
53A	K31-00858-20	THERMOSTAT DUAL PROBE -29C+29C	1
53B*	K31-00858-25	THERMOSTAT DUAL PROBE -29C+29C	1

OPTIONAL DATALOGGING CAPABILITIES			
-----------------------------------	--	--	--

54	360-13398-00	HARNESS DATA DOWNLOAD 18"LG	1
55	K31-00888-20	THERMOSTAT COOL DUAL DATA LABEL	1

OPTIONAL HEATER			
-----------------	--	--	--

56	K31-00858-30	THERMOSTAT DUAL PROBE COOL/HEAT	1
----	--------------	---------------------------------	---

* K31 00858 25 REPLACES K31 00858 20 IN THE TCR-104-10, BUT THE K31 00858 20 WILL STILL FUNCTION IN THIS APPLICATION.

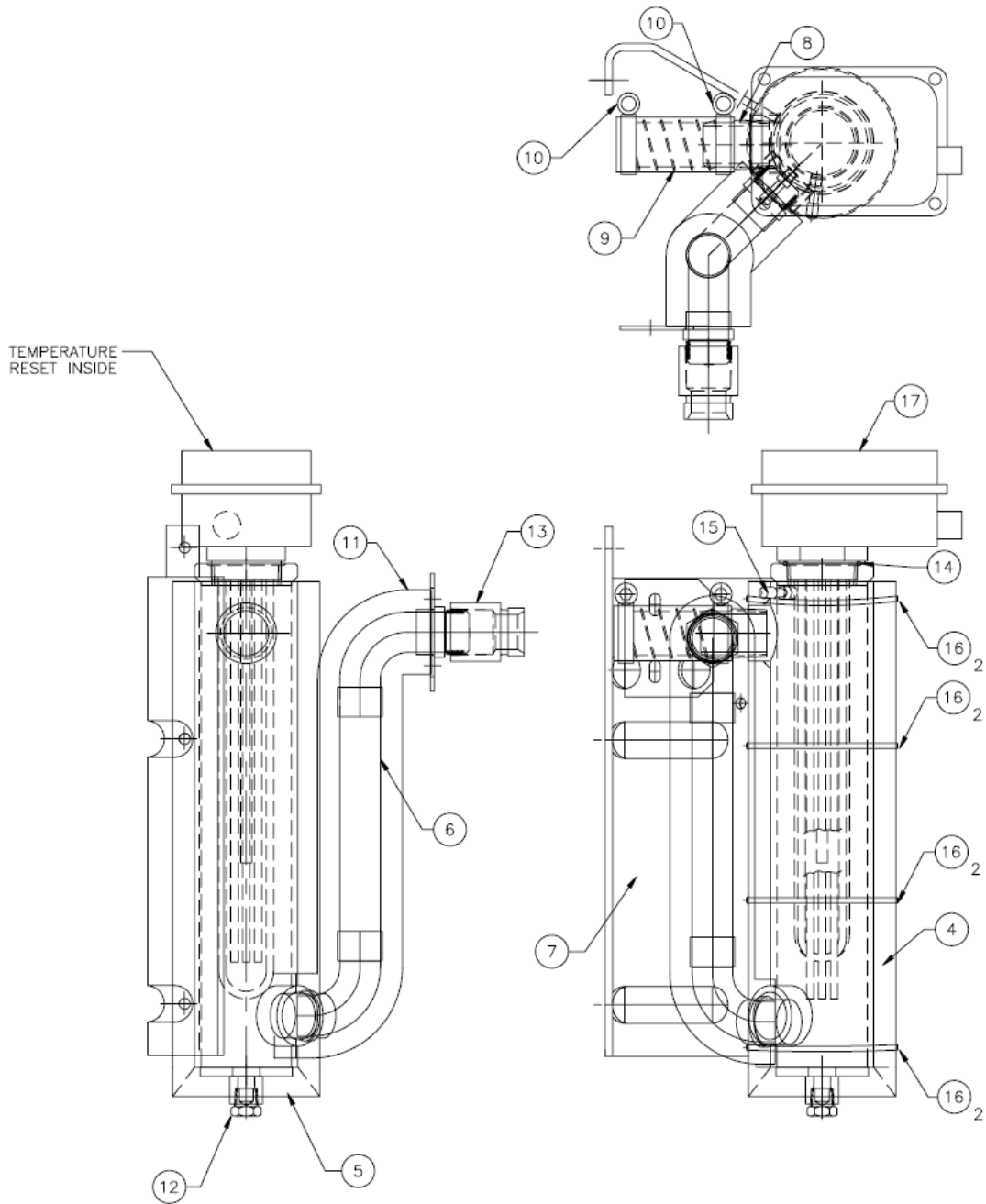

**SECTION 8.4 A
OPTIONAL HEATER**

SECTION 8.4A**OPTIONAL HEATER**

ITEM	PART NO.	DESCRIPTION	QTY.
1	360-13626-00	KIT HEATER COMPLETE TCR-104	1
		(INCLUDES ITEMS 2 THRU 38)	
2	360-12560-10	HEATER GLYCOL 5KW INSTALLATION REMOTE	1
		(INCLUDES ITEMS 3 THRU 17)	1
3	360-12560-11	FRAME INSULATED COMPLETE WITH OUT HEATER	1
		(INCLUDES ITEMS 4 THRU 16)	
4	060-13490-02	INSULATION HEATER REMOTE TCR-104	1
5	060-13597-01	INSULATION HEATER BOTTOM WITH HOLE	1
6	360-13591-00	PIPING HEATER TCR-104	1
7	360-12573-10	TANK GLYCOL HEATER WELDMENT	1
8	060-12812-00	CONNECTION PUMP INLET 2.25"LG	1
9	060-12592-06	TUBE PVC CLEAR WITH WIRE 1.5"ID 4	1
10	K21-16379-05	CLAMP CONSTANT TORQUE SS 1-1/16	2
11	K10-07504-46	INSULATION THERMAL 1-3/8 ID x 3/4 WALL	2 FT
12	K23-13069-04	PLUG PIPE HEX BRASS 1/2 MPT	1
13	K23-13230-05	CONNECTOR MALE 1 1/4-11BSP 1-1/4FP	1
14	K28-10976-229	RING O TEFLON 2.38 ID 2.63 OD	1
15	K22-06959-00	VALVE TANK 1/8 MPT x TIRE VALVE	1
16	K25-23765-03	STRAP CABLE BLACK .18 WIDE 14.5 LONG	8
17	K25-26356-00	HEATER IMMERSION 5 KW WITH RESET	1

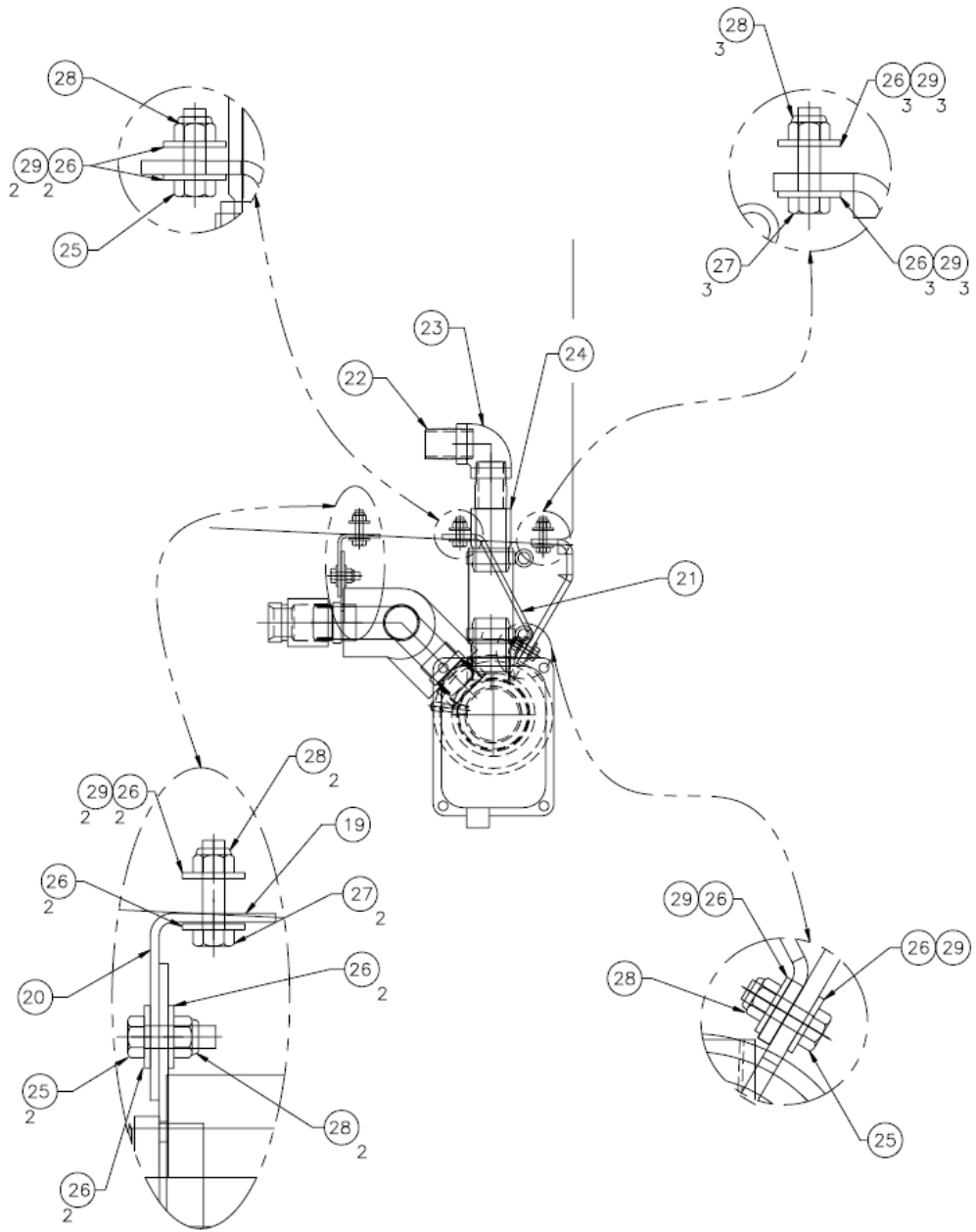

**SECTION 8.4 B
OPTIONAL HEATER
INSTALLATION**

SECTION 8.4B**OPTIONAL HEATER – INSTALLATION**

ITEM	PART NO.	DESCRIPTION	QTY.
18	360 13584-00	INSTALL HEATER PIPING TCR-104	1
		(INCLUDES ITEMS 19 THRU 29)	
19	060-13589-00	INSULATOR HEATER BRACKET & PLATE	1
20	060-13587-00	BRACKET HEATER MOUNTING TCR-104	1
21	060-13583-00	BRACKET SUPPORT HEATER WHITE	1
22	K23-13228-61	NIPPLE SS 1" MPT SCH 40 2" LG	1
23	K23-13255-06	ELBOW SS 90 DEGREE 1" FPT 150# TYP	1
24	360-13582-00	NIPPLE SS 1" NPT TO 1-1/4" HOSE	1
25	K21-14059-00	SCREW HEX SS 5/16-18 X 1	4
26	K21-14072-00	WASH FLAT SS 516 .38 ID .88 OD	18
27	K21-14730-00	SCREW HEX SS 5/16-18 X 1-1/4	5
28	K21-14921-07	NUT LOCK SS 5/16-18	9
29	K21-50492-04	WASH INSULATED PVC 5/16	12

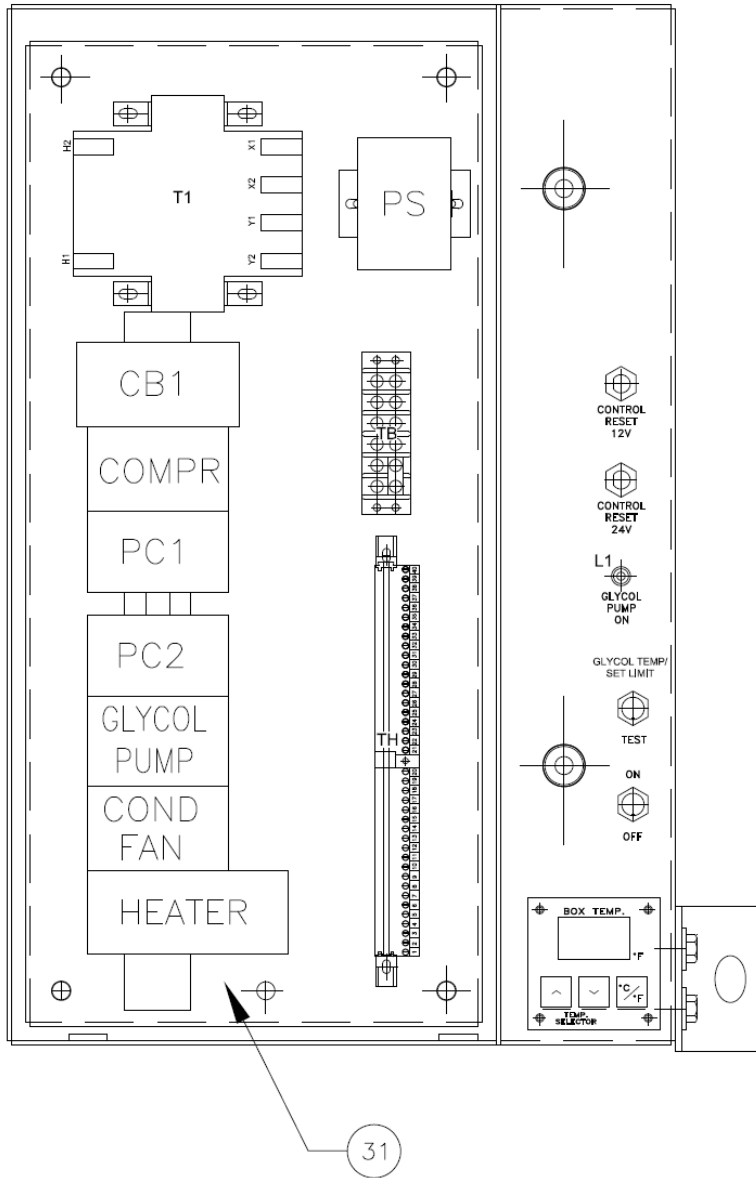

SECTION 8.4 C
 OPTIONAL HEATER
 ELECTRICAL BOX MODIFICATION

SECTION 8.4C OPTIONAL HEATER – ELECTRICAL BOX MODIFICATION

ITEM	PART NO.	DESCRIPTION	QTY.
30	360-12585-07	INSTALL ELECTRIC BOX OPTIONAL 5 KW HEATER	1
		(INCLUDES ITEM 31)	
31	K24-17239-00	STARTER 9A 3P 6-9.2 OL 24 VAC	1

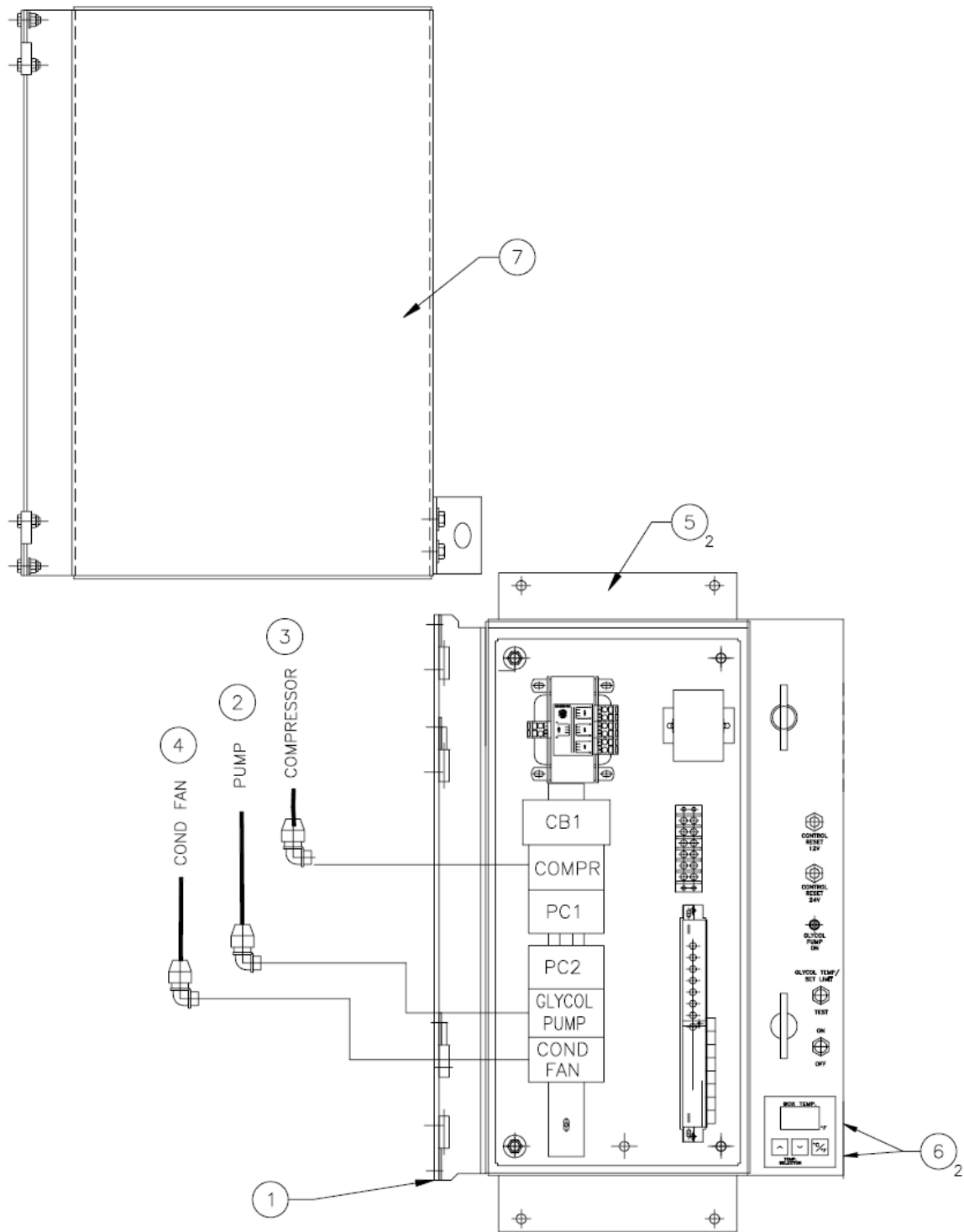

SECTION 8.5
OPTIONAL REMOTE ELECTRICAL BOX KIT FOR TCR-104-08
PARTS SHOWN ARE THE ONLY DIFFERENCE FROM UNIT MOUNTED ELECTRICAL BOX

SECTION 8.5 OPTIONAL REMOTE MOUNTED – ELECTRICAL BOX

ITEM	PART NO.	DESCRIPTION	QTY.
1	360-13829-00	BOX ELECTRIC COMPLETE REMOTE TCR-108	1
		(INCLUDES ITEMS 2 THRU 6)	
2	360-15049-01	CABLE ELECTRICAL BOX TO PUMP	1
3	360-15051-01	CABLE ELECTRICAL BOX TO COMPRESSOR	1
4	360-15052-01	CABLE ELECTRICAL BOX TO FAN MOTOR	1
5	060-13828-00	PLATE ELECTRICAL BOX REMOTE MOUNTING	2
6	K28-10936-03	PLUG SEAL POLY FLUSH .38 (.11)	2
7	360-13816-00	DOOR REPLACE ELECTRICAL BOX TCR-104 UNIT	1

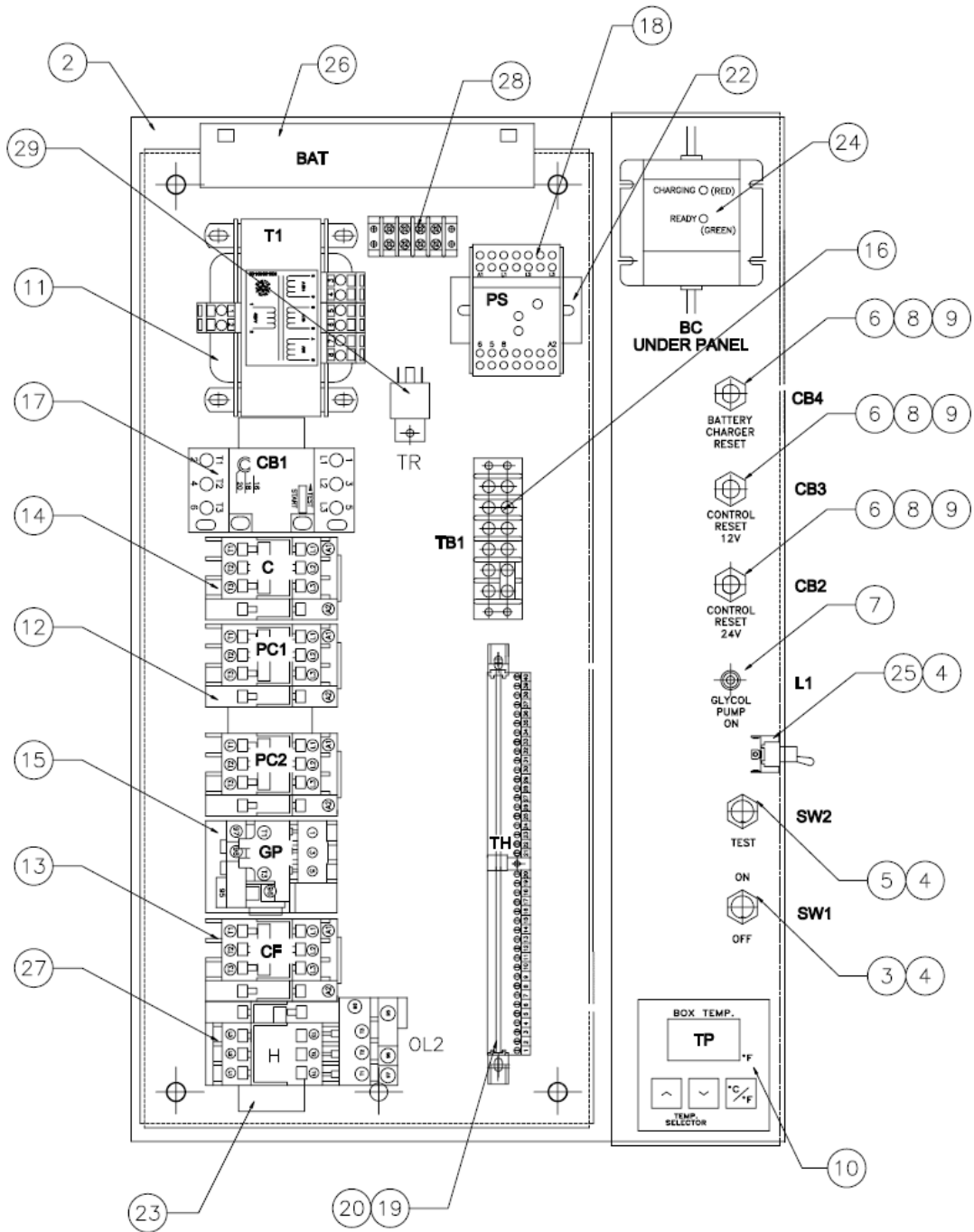

SECTION 8.6A
TCR-104-09 ELECTRICAL BOX
WITH VERSION 2 DATALOGGER & ALARMS

SECTION 8.6A TCR-104-09 ELECTRICAL BOX W/ VER 2 DATALOGGER & ALARMS

ITEM	PART NO.	DESCRIPTION	QTY.
1	360-15134-09	BOX ELECTRICAL TCR-104-09 COMPLETE	1
2	060-15023-04	BOX ELECTRICAL SILKSCREEN TCR-104	1
3	K24-07458-00	SWITCH TOGGLE DPST ON-OFF (4) #6 SCREW	1
4	K24-17239-00	BOOT TOGGLE SWITCH	3
5	K24-22152-00	SWITCH TOGGLE SPDT MOM *ON-OFF-*ON #6	1
6	K24-22233-00	CIRCUIT BREAKER 4 A 2P 50/60HZ	3
7	K25-26330-00	LAMP INDICATOR CHROME YELLOW 24V	1
8	K28-10809-00	BOOT CIRCUIT BREAKER 15/32-32THD CLEAR	3
9	K28-10810-00	ADAPTER BOOT PUSH BUTTON THREADED	3
10	K3- 00811-00	DISPLAY TEMPERATURE AND SELECTOR F/C	1
11	K25-26404-00	TRANSFORMER 180VA 460V 110/24/12 LAB	1
12	K24-22148-00	CONTACTOR REVERSING 9A 6P 24VAC 50	1
13	K24-22155-00	CONTACTOR 9A 3P 24/20 VAC 60/50 HZ	1
14	K24-22156-00	CONTACTOR 16A 3P 24VAC 50/60 Hz CO	1
15	K24-22268-00	OVERLOAD RELAY 1.8-2.8 AMP	1
16	K25-21619-06	BLOCK TERMINAL 6-32 6P	1
17	K24-22269-00	CIRCUIT BREAKER 16-20 AMP 3P	1
18	K31-00809 00	PHASE SENSOR 440V	1
19	360-10829 00	BASE THERMOSTAT	1
20	K25-26139 00	HOLDER CARD 4" GREEN (SET)	1
22	060-11147-00	RAIL MOUNTING DIN #3 X 2.25" LONG	1
23	060-12110-00	RAIL MOUNTING DIN #3 X 14.53 LONG	1
24	360-12473-10	CHARGER BATTERY MOD TCR-104	1
25	K24-21355-00	SWITCH TOGGLE SPDT ON (MOM -ON)	1
26	360-13396-01	BATTERY 12V 1.8AH MTG TAPE 24"	1
27	K24-22325-00	STARTER 9A 3P 6-9.2 OL 24 VAC	1
28	K25-21619-04	BLOCK TERMINAL 6-32 4P	1
29	K24-22121-00	RELAY 12 VDC SPDT 30A	1

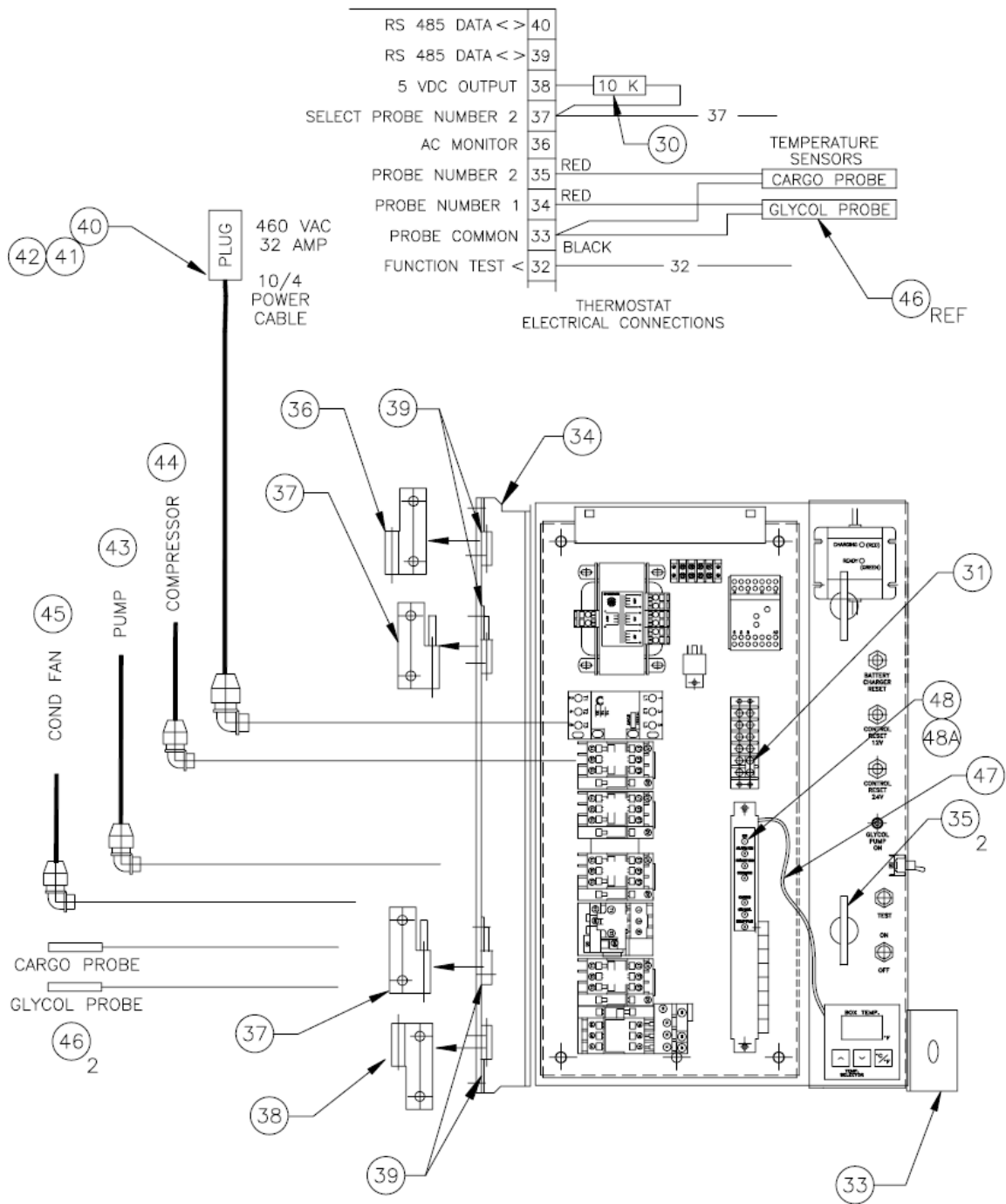

SECTION 8.6B
TCR-104-09 ELECTRICAL BOX
WITH VERSION 2 DATALOGGER & ALARMS

SECTION 8.6B TCR-104-09 ELECTRICAL BOX W/ VER 2 DATALOGGER & ALARMS

ITEM	PART NO.	DESCRIPTION	QTY.
30	360-14461-02	RESISTOR 10K OHM 1/4 WATT +-5% ASSEMBLY	1
31	K25-10444-00	JUMPER TERMINAL BLOCK #6 SCREW	1
32	K25-26134-00	BASE TYRAP MOUNTING BLACK ADHESIVE	1
33	060-10820-00	RETAINER ELECTRICAL BOX SS PASS & POLISH	1
34	060-10748-00	BRACKET HINGE ELECTRICAL BOX	1
35	K21-16313-00	FASTENER BABY ANTILUSE M8x1.25	2
36	K29-17879-01	HINGE SLIP SS 9/32 HOLES SOCKET	1
37	K29-17879-02	HINGE SLIP SS 9/32 HOLES WITH PIN	2
38	K29-17880-01	HINGE SLIP SS 9/32 HOLES SOCKET	1
39	060-09113-00	INSULATOR HINGE	4
40	360-12133-00	CABLE MAIN POWER 460 VAC 55 FT	1
41	K25-20474-00	PLUG POWER 32A 380/440V 3P+G W	1
42	060-11114-01	CORD ELECTRICAL SO 10/4 CUT 55'LG	1
43	360-15049-00	CABLE ELECTRICAL BOX TO PUMP	1
44	360-15051-00	CABLE ELECTRICAL BOX TO COMPRESSOR	1
45	360-15052-00	CABLE ELECTRICAL BOX TO FAN MOTOR	1
46	360-13807-00	KIT UNIVERSAL PROBE	2
		(INCLUDES ITEMS 46A, 46B & 46C)	2
46A	K25-26097-00	PROBE TEMPERATURE .31 DIAx6"LGx 13 FT	2
46B	K25-26120-28	MARKER WIRE .25 ID CARGO	2
46C	K25-26120-29	MARKER WIRE .25 ID GLYCOL	2
47	360-12540-01	CABLE RIBBON SHLD 18" 10 WIRES	1
48	K31-00858-25	THERMOSTAT DUAL PROBE -29C+29C	1

(NOTE: K31-00858-25 REPLACES K31-00858-20 IN THE TCR-104-10, BUT THE K31-00858-20 WILL STILL FUNCTION IN THIS APPLICATION.)

OPTIONAL HEATER			
48A	K31-00858-30	THERMOSTAT DUAL PROBE COOL/HEAT	1

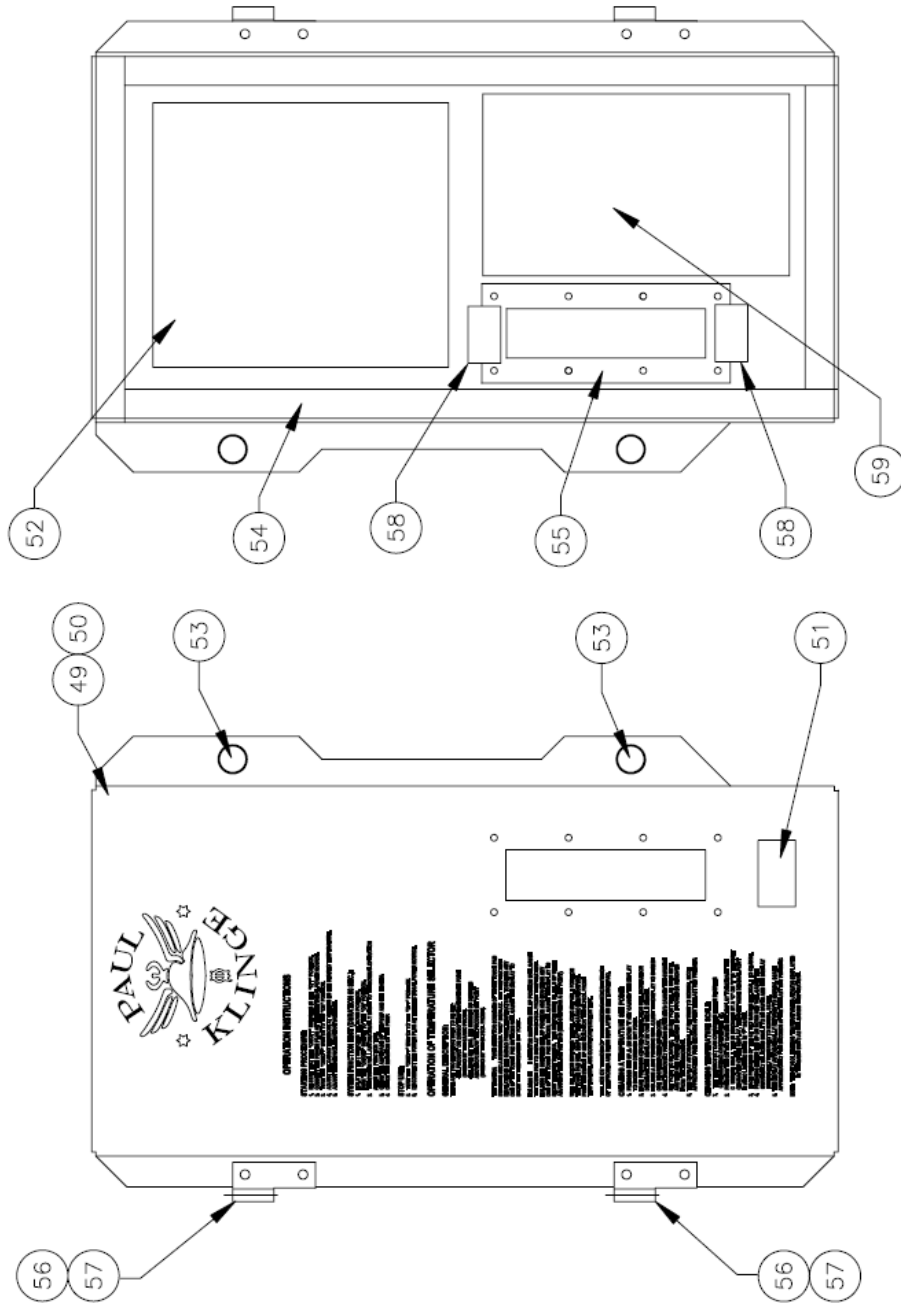

**SECTION 8.6C
TCR-104-09 ELECTRICAL BOX
WITH VERSION 2 DATALOGGER & ALARMS**

SECTION 8.6C TCR-104-09 ELECTRICAL BOX W/ VER 2 DATALOGGER & ALARMS

ITEM	PART NO.	DESCRIPTION	QTY.
49	360-15140-09	DOOR ASSEMBLY TCR-104-09	1
		(INCLUDES ITEMS 2 THRU 11)	
50	060-15024-03	DOOR ELECTRICAL BOX SILKSCREEN TCR-104	1
51	K35-05899-00	LABEL DANGER HIGH VOLTAGE 1.5x3	1
52	K35-05875-09	LABEL ELECTRICAL SCHEMATIC TCR-104-09	1
53	K28-10847-04	GROMMET INSERT .875 HOLE SIZE	2
54	K28-10813-00	STRIP SPONGE 3/8x7/8 SOFT CLOSED	6
55	K28-10945-00	WINDOW DOOR ELECTRICAL BOX	1
56	K29-17880-01	HINGE SLIP SS 9/32 HOLES SOCKET	2
57	060-09113-00	INSULATOR HINGE	2
58	060-12178-01	STRIP SPONGE 3/4 x 1 x 2	2
59	K35-05966-09	LABEL COMPONENT LAYOUT TCR-104-09	1

Suggested Spare Parts

SUGGESTED SPARE PARTS TCR-104-07, -08, -09, -10, -20			REEFER QTY	ELECT BOX QTY
ITEM	PART NUMBER	DESCRIPTION		
1	360-10829-00	BASE THERMOSTAT		1
2	360-12540-01	CABLE RIBBON SHLD 18" 10 WIRES		1
3	360-13460-00	VALVE RELIEF 3/4 MPT 50 PSI KIT	1	
4	360-13807-00	KIT THERMOSTAT PROBE UNIVERSAL	2	
5	K22-06950-01	VALVE SUCTION PRESS REG 1-1/8 SHORT	1	
6	K24-07458-00	SWITCH TOGGLE DPST ON-OFF (4) #6 SCR		1
7	K24-17239-00	BOOT TOGGLE SW		3
8	K24-22148-00	CONTACTOR REVRS 9A 6P 24VAC 50-60 Hz		1
9	K24-22152-00	SWITCH TOGGLE SPDT (ON)-OFF-(ON) #6SCR		1
10	K24-22155-00	CONTACTOR 9A 3P 24/20 VAC (COND)		1
11	K24-22156-00	CONTACTOR 16A 3P 24VAC (COMPR)		1
12	K24-22233-00	CIRCUIT BREAKER 4 A 2P 50/60HZ		1
13	K24-22268-00	OVERLOAD RELAY 1.8-2.8 AMP (PUMP)		1
14	K24-22269-00	CIRCUIT BREAKER 16-20 AMP 3P		1
15	K25-20474-00	PLUG POWER 32A 380/440V 3P+G		1
16	K25-26095-00	CONTROL HP NC OPEN 450 CLOSE 300	1	
17	K25-26330-00	LAMP INDICATOR CHROME YELLOW 24V		1
18	K25-26404-00	TRANSFORMER 180VA 460V 110/24/12 LABEL		1
19	K26-24906-00	FILTER/DRIER 1/2MFL HC W/LABEL	1	
20	K26-25035-00	KIT PUMP SEAL #11 EPDM	1	
21	K28-10809-00	BOOT CIRCUIT BREAKER 15/32-32THD CLEAR		2
22	K28-10810-00	ADAPTER BOOT PUSH BUTTON		2
23	K28-10976-124	RING-O TEFLON 1.25 ID (PUMP OUTLET LINE)		1
24	K28-10995-010	SEAL O-RING .25 ID (LAMP)		1
25	K31-00809-00	PHASE SENSOR 480V		1
26	K31-00811-00	DISPLAY TEMPERATURE AND SELECTOR F/C		1
27	K31-00858-30	THERMOSTAT DUAL PROBES WITH HEAT		1

EXTENDED SPARE PARTS

28	K15-00019-01	COMPR SERVICE. A REPLACEMENT COMPLETE WITH GASKETS BUT NO SERVICE VALVES	1	
29	360-12208-03	PUMP MODIFICATION 1.5 HP	1	
30	K24-21158-00	MOTOR 1725 RPM - 2 HP CONDENSER	1	
31	360-12133-00	CABLE MAIN POWER 480 VAC 55 FT INCLUDES POWER PLUG K25--20474-00		1

OPTIONAL HEATER

32	K25-26356-05	HEATER IMMERSION 5 Kw	1	
33	K24-22325-00	STARTER 9A 3P 6-9.2 OL 24 VAC		1

OPTIONAL POWER SUPPLY DUAL VOLTAGE TRANSFORMER 240VAC TO 480VAC

34	360-11844-00	TRANSFORMER 15 KW (COMPLETE WITH CABLES)		1
35	K25-26092-00	TRANSFORMER 15 KW (NO CABLES)		1
36	360-10883-00	CABLE POWER & RECEPTACLE 480V 6'LG		1
37	K25-23732-00	RECEPTACLE POWER 32A 480V 3P+G 3h		1
38	360-11845-00	CABLE POWER & PLUG 480V 55 FOOT LG		1
39	K25-26101-00	PLUG POWER 60A 250V 3P+G		1